

# USER'S MANUAL

## **iHPC300**

**4U Rackmount GPU Workstation  
with Intel® Xeon® Scalable  
Processor, supports multiple  
accelerator Cards**

**User's Manual**



[www.axiomtek.com](http://www.axiomtek.com)

## **Disclaimers**

This manual has been carefully checked and believed to contain accurate information. Axiomtek Co., Ltd. assumes no responsibility for any infringements of patents or any third party's rights, and any liability arising from such use.

Axiomtek does not warrant or assume any legal liability or responsibility for the accuracy, completeness or usefulness of any information in this document. Axiomtek does not make any commitment to update the information in this manual.

Axiomtek reserves the right to change or revise this document and/or product at any time without notice.

No part of this document may be reproduced, stored in a retrieval system, or transmitted, in any form or by any means, electronic, mechanical, photocopying, recording, or otherwise, without the prior written permission of Axiomtek Co., Ltd.

## **CAUTION**

Wrong type of batteries may cause explosion. It is recommended that users only replace with the same or equivalent type of batteries as suggested by the manufacturer once properly disposing of any used ones.

**©Copyright 2021 Axiomtek Co., Ltd.**

**All Rights Reserved**

**August 2021, Version A1**

**Printed in Taiwan**

## ESD Precautions

Computer boards have integrated circuits sensitive to static electricity. To prevent chipsets from electrostatic discharge damage, please take care of the following jobs with precautions:

- Do not remove boards or integrated circuits from their anti-static packaging until you are ready to install them.
- Before holding the board or integrated circuit, touch an unpainted portion of the system unit chassis for a few seconds to discharge static electricity from your body.
- When handling boards and components, wear a grounding wrist strap available from most electronic component stores.

## Trademarks Acknowledgments

Axiomtek is a trademark of Axiomtek Co., Ltd.

Intel® and Celeron® are trademarks of Intel Corporation.

Windows® is a trademark of Microsoft Corporation.

AMI is a trademark of American Megatrend Inc.

IBM, PC/AT, PS/2, and VGA are trademarks of International Business Machines Corporation.

Other brand names and trademarks are the properties and registered brands of their respective owners.

# Table of Contents

---

Disclaimers .....	ii
ESD Precautions.....	iii
<b>Section 1 Introduction.....</b>	<b>1</b>
1.1 Features .....	2
1.2 Specifications .....	2
1.3 M/B Block Diagram & System Dimensions.....	4
1.4 Outlets & System Layout.....	6
1.5 Packing list .....	7
1.6 Jumper Settings .....	8
1.6.1 Temperature Sensor Source Select (JP2).....	9
1.6.2 PCIe x16 slot bifurcation (JP13).....	9
1.6.3 Clear CMOS (JP19) .....	9
1.6.4 AT/ATX Mode Select (JP20).....	10
1.7 Connectors.....	11
1.7.1 VGA Connector (CN1).....	12
1.7.2 LAN and USB 3.1 Connectors (CN3 and CN4) .....	12
1.7.3 External Sensor Header (CN5) .....	12
1.7.4 GPIO Header (CN6).....	13
1.7.5 TPM Pin Header (CN11) .....	13
1.7.6 M.2 2280 Key M PCIe x4 SSD slot (CN12) .....	14
1.7.7 SMBus Header (CN14) .....	14
1.7.8 Voltage Monitor Header (CN15).....	15
1.7.9 Front Panel Header (CN16) .....	15
1.7.10 Power Input Connectors (ATX1, ATX2, CN18 and CN19) .....	16
1.7.11 Internal USB 3.1 Gen1 Connector (CN20).....	17
1.7.12 COM1 Connector (COM1) .....	17
1.7.13 Fan Connectors (FAN1~FAN3 and FAN5~6).....	18
1.7.14 Internal USB Headers (USB1~4) .....	18
1.7.15 SATA 3.0 Connectors (SATA1 ~ SATA6).....	19
1.7.16 LAN Active LED connectors (JP3 and JP10) .....	19
1.7.17 Programmable LED connectors (JP4) .....	19
1.7.18 Keyboard and PS/2 Mouse Connector (PS1) .....	19
1.7.19 Intel® HD Audio Digital Header (HDA1).....	20
<b>Section 2 Hardware Installation .....</b>	<b>21</b>
2.1 Installing the CPU.....	21
2.2 Installing the Memory .....	25
<b>Section 3 AMI BIOS Setup Utility .....</b>	<b>27</b>

3.1	Starting.....	27
3.2	Navigation Keys .....	27
3.3	Main Menu .....	29
3.4	Advanced Menu .....	30
3.5	Platform Configuration.....	41
3.6	Socket Configuration.....	46
3.7	Security Menu .....	49
3.8	Boot Menu.....	50
3.9	Save & Exit Menu.....	51
<b>Appendix A Watchdog Timer .....</b>		<b>53</b>
	About Watchdog Timer.....	53
	How to Use Watchdog Timer .....	53
<b>Appendix B TPM Module Installation .....</b>		<b>55</b>
<b>Appendix C Configuring SATA for RAID.....</b>		<b>59</b>
	Configuring SATA Hard Drive(s) for RAID Function .....	59
<b>Appendix D Digital I/O.....</b>		<b>65</b>
	Digital I/O Software Programming.....	65

**This page is intentionally left blank.**

# Section 1

## Introduction



The iHPC300 is built on the LGA4189 socket Intel® Xeon® Scalable processor and provides massive parallel computing power and networking flexibility with three PCIe x16 slots, three PCIe x8 slots, and NVMe M.2 Key M 2280 interface with PCIe x4 signal, supporting up to six accelerator cards (GPUs and high-speed NVMe storage). This reliable and efficient GPU workstation also supports six SATA-600 ports with integrated RAID 0/1/5/10 for protection against data loss. To offer a wide range of I/Os, the iHPC300 has six USB 3.1 Gen1 ports, seven USB 2.0 ports, one RS-232/422/485 port, two GbE LAN ports with Intel® Ethernet controller i210-AT, one VGA port, 8-channel programmable digital I/O port, one HD Codec audio, SMBus, and one PS/2 keyboard and mouse. Trusted Platform Module 2.0 (TPM 2.0) is also available as an optional feature to ensure critical information security. The iHPC300 can operate under a wide temperature range from 0°C to +40°C. With increased computing power, it is suitable for performing deep learning AI, video surveillance, industrial automation and other diverse applications.”

## 1.1 Features

- LGA4189 socket Intel® Xeon® Processor Scalable, up to 270W, 40 cores
- Six DDR4-3200 R-DIMM un-buffered non-ECC/ECC memory, up to 384GB
- Expansion slots: 3 PCIe x16 and 3 PCIe x8, supporting up to three accelerator cards
- Supports M.2 Key M 2280
- TPM 2.0 supported (optional)

## 1.2 Specifications

- **CPU**
  - LGA4189 Socket Intel® Xeno® Scalable Ice Lake-SP processor up to 270W, 40 cores
- **Chipset**
  - Intel® C621A
- **BIOS**
  - AMI BIOS
- **System Memory**
  - 6 x 288-pin DIMM sockets
  - Maximum 384GB DDR4 memory (max. 64GB per slot)
  - Supports 3200MHz
  - Supports the RDIMM un-buffered non-ECC/ ECC memory
- **Drive Capacity**
  - Exposed 3 x 5.25" HDD drive bay and 1 x 3.5" HDD drive bay
  - Internal 3 x 3.5" HDD drive bay or 2 x 3.5" or 1 x 2.5"
- **Cooling**
  - 1 x 12 cm PWM front fan
  - 2 x 8 cm easy-swap rear fan
- **Front Panel**
  - Indicator: 1 x power LED, 1 x HDD LED, 2 x LAN activity LED & 1 x programmable LED
  - Controls: 1 x power switch & 1 x system reset
  - Connector: 2 x USB 3.1 Gen1
- **Watchdog Timer**
  - 255 levels, 1 ~ 255 sec
- **Onboard Rear I/O**
  - 1 x PS/2 keyboard and mouse
  - 1 x RS-232/422/485 (BIOS selection)
- **USB Interface**
  - 6 x USB3.1(Gen1) ports (4 x real I/O, 2 x internal box header)
  - 7 x USB 2.0 ports (6 x internal box header, 1 x 180D TypeA)



- **Ethernet**
  - LAN1: 1000/100/10Mbps Gigabit/Fast Ethernet supports Wake-on-LAN, PXE Boot ROM with Intel® i210-AT
  - LAN2: 1000/100/10Mbps Gigabit/Fast Ethernet supports Wake-on-LAN, PXE Boot ROM with Intel® i210-AT
- **Storage**
  - 6 x SATAIII with RAID 0/1/5/10
  - 1 x M.2 M-Key 2280 with PCIe x4 signal for NVMe SSD
- **Audio**
  - Supports HD audio interface as a 2x8 pin header
  - Supports audio kit AX93242 with MIC-in/Line-in/Line-out/Speaker-out (optional kit)
- **Display**
  - 1 x 15-pin D-Sub as VGA connector. Resolution max. up to 1920x1200 @60Hz
  - AST2510
- **Expansion Interface**
  - Slot 1: PCIe x8 (Gen3)
  - Slot 2: PCIe x16 (Gen4)
  - Slot 3: M.2 Key M 2280 (signal: x4)
  - Slot 4: PCIe x16 (Gen4)
  - Slot 5: PCIe x8 (signal: x0 or x8, Gen3)
  - Slot 6: PCIe x16 (signal: x16 or x8, Gen3)
  - Slot 7: PCIe x8 (Gen3)



Note

**Default: slot 6 provides PCIe x16 signal, while slot 5 has no signal. If you want to switch slot 5 and slot 6 signal to PCIe x8 signal, please refer to section 2.4.2.**

- **SMBus**
  - System Management Bus for advanced monitoring/control
- **Digital I/O**
  - 8 channels programmable
- **Power Supply Type (2 SKU: 1200W or 2000W PSU to choose from)**
  - 1200W: AC input voltage 100 to 240V
  - 2000W: AC input voltage 200 to 240V
- **Operating Temperature**
  - 0°C ~ 40°C (+32°F to +104°F)
- **Storage Temperature**
  - -20°C ~ 85°C (-4°F to +140°F)
- **Operating Humidity**
  - 10% to 95% relative humidity, non-condensing
- **Dimensions**
  - 430 mm (16.9") (W) x 174.8 mm (6.9") (H) x 515mm (20.3") (D)



Note

**All specifications and images are subject to change without notice.**

### 1.3 M/B Block Diagram & System Dimensions

The following figure shows you the M/B block diagram of iHPC300.

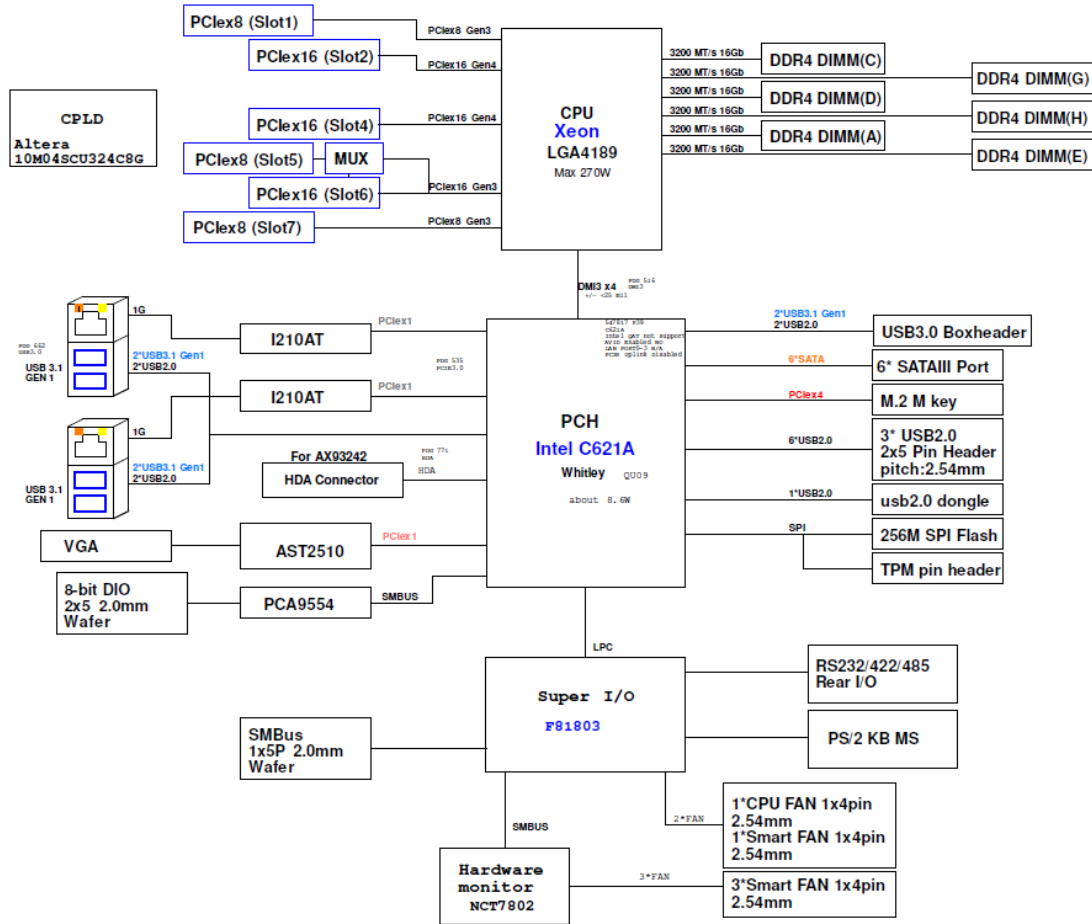

The following diagram shows you system dimensions.

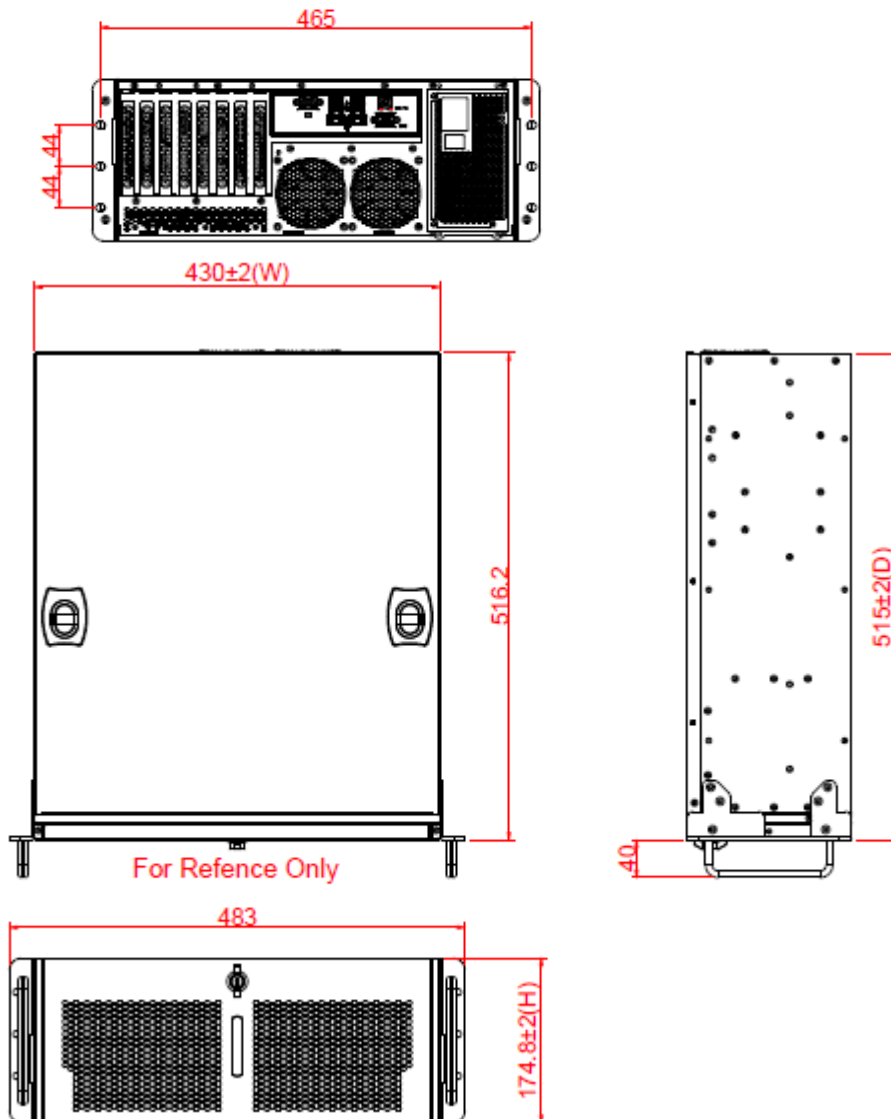

## 1.4 Outlets & System Layout

The following figures shows you the outlets on the front panels of iHPC300.

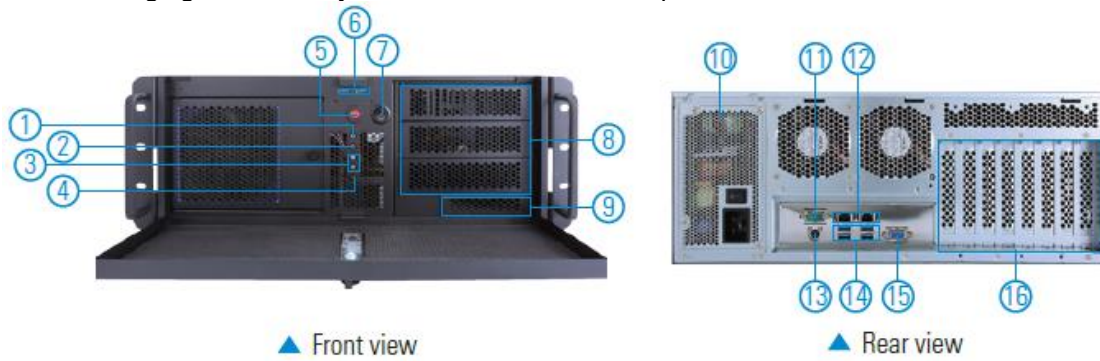

- 1. Power LED
- 2. HDD LED
- 3. LAN activity LED
- 4. Programmable LED
- 5. System reset
- 6. 2 x USB 3.1 Gen1
- 7. Power switch
- 8. 3 x 5.25" HDD drive bay

- 9. 1 x 3.5" HDD drive bay
- 10. 1200W or 2000W power supply
- 11. COM port
- 12. 2 x LAN
- 13. PS/2 Combo Port
- 14. 4 x USB 3.1 Gen1
- 15. VGA
- 16. Expansion slots

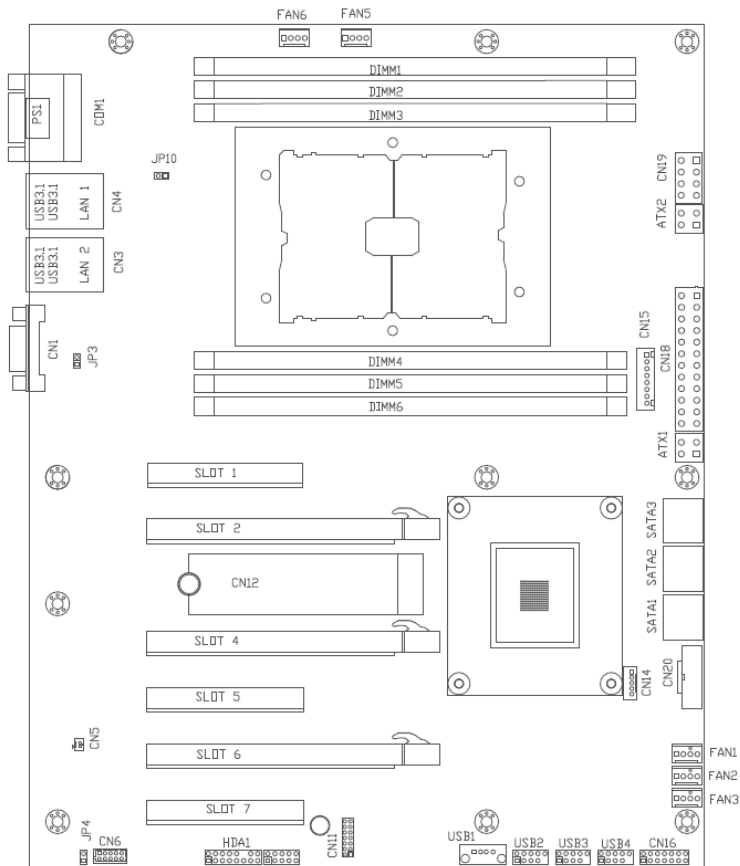

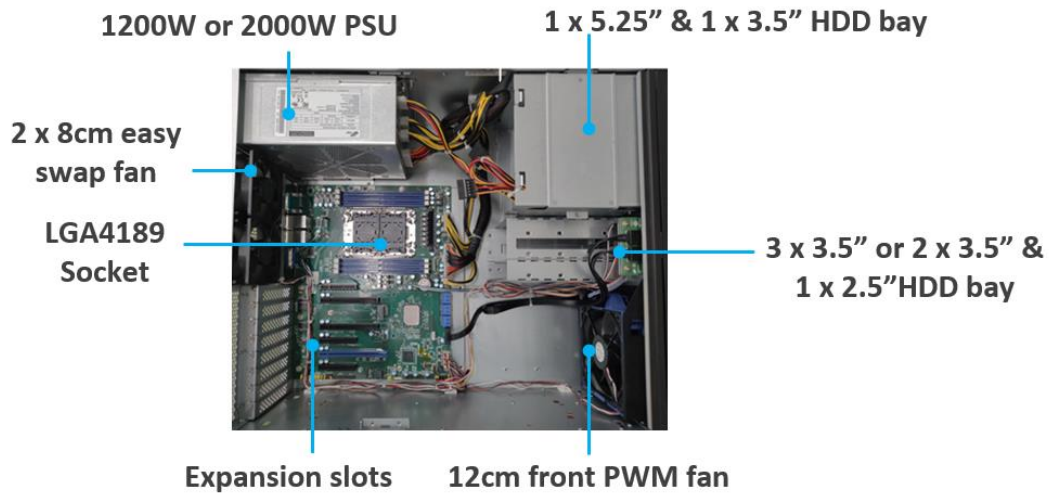

## 1.5 Packing list

The package bundled with your iHPC300 should contain the following items:

- iHPC300 unit x 1
- CPU clip x 1
- Power cord x 1
- SATA cable x 2

If you cannot find this package or any items are missing, please contact Axiomtek distributors immediately.

## 1.6 Jumper Settings

### Pin description

A jumper is a small component consisting of a jumper clip and jumper pins. Install a jumper clip on two jumper pins to close the jumper pins. Remove the jumper clip from two jumper pins to open the jumper pins. The following illustration shows how to set up a jumper.

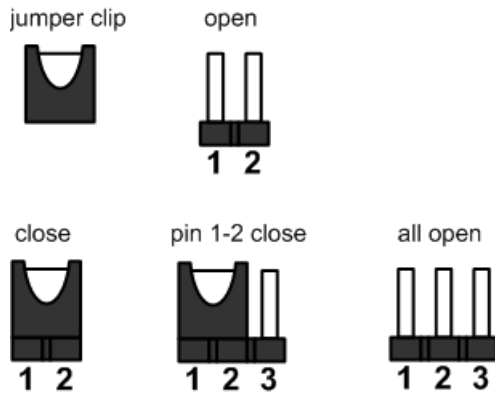

Note

To identify the first pin of a header or jumper, please refer to the following information:

- Usually, there is a thick line or a triangle near the header or jumper pin 1.

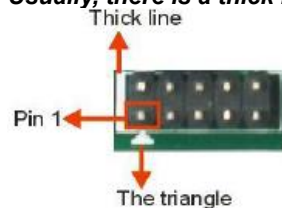

- A square pad, which you can find on the back of the motherboard, is usually used for pin 1.



Before applying power to the iHPC300, make sure all of the jumpers are in factory default position. Below you can find a summary table of all jumpers and onboard default settings.



Note

Turn off power before changing any default jumper settings.

Jumper	Description	Setting
JP2	System temperature sensor source select Default: internal sensor External sensor can be installed on 1-2	2-3 Close
JP13	PCIe x16 slot using location slot 5 Default: x16	1-2 Close
JP19	Clear CMOS Default: Normal operation	1-2 Close
JP20	AT/ATX power mode select Default: AT mode	1-2 Close

### 1.6.1 Temperature Sensor Source Select (JP2)

Use these jumpers (3x1-pin p=2.54mm) to set temperature sensor source to operate from an external sensor or in onboard mode.

Function	Setting
External Sensor (CN5)	1-2 close
Onboard Sensor (Default)	2-3 close



Note

*An external sensor can be installed at 1-2.*

### 1.6.2 PCIe x16 slot bifurcation (JP13)

Use these jumpers (3x1-pin p=2.54mm) to set signal for slot location 5 and 6 used as PCIe x16 slot.

Function	Setting
X16 and no signal (Default)	1-2 close
X8 and X8	2-3 close



Note

*If the setting is 1-2 close, slot location 6 is for PCIe x16 signal and slot location 5 has no signal.  
If the setting is 2-3 close, slot location 6 is PCIe x8 signal and slot location 5 is PCIe x8.*

### 1.6.3 Clear CMOS (JP19)

This jumper (3x1-pin p=2.54mm) allows you to clear the Real Time Clock (RTC) RAM in CMOS. You can clear the CMOS memory of date, time, and system setup parameters by erasing the CMOS RTC RAM data. The onboard button cell battery powers the RAM data in CMOS, which includes system setup information such as system passwords.

To erase the RTC RAM:

1. Turn OFF the computer and unplug the power cord.
2. Remove the onboard battery.
3. Move the jumper clip from pins 1-2 (default) to pins 2-3. Keep the clip on pins 2-3 for about 5~10 seconds, then move the clip back to pins 1-2.
4. Re-install the battery.
5. Plug the power cord and turn ON the computer.
6. Hold down the <Del> key during the boot process and enter BIOS setup to re-enter data.

Function	Setting
Normal operation (Default)	1-2 close
Clear CMOS	2-3 close



### 1.6.4 AT/ATX Mode Select (JP20)

This 3x1-pin p=2.54mm jumper allows you to select AT or ATX power mode.

Function	Setting
AT mode (Default)	1-2 close
ATX mode	2-3 close





## 1.7 Connectors

Signals go to other parts of the system through connectors. Loose or improper connection might cause problems, Make sure all connectors are properly and firmly connected. Here is a summary table showing the connectors on the hardware.

Connector	Description
CN1	VGA Connector
CN3	LAN + USB3.1 GEN1 Connector
CN4	LAN + USB3.1 GEN1 Connector
CN5	External Sensor Header
CN6	GPIO Connector
CN11	TPM 2.0 Connector (Optional)
CN12	M.2 Connector
CN14	SMBus Header
CN15	Voltage Monitor Header
CN16	Front Panel Header
CN18	24-pin ATX Power Input Connector
CN20	Internal USB3.1 GEN1 Connector
ATX1	ATX 12V Power Input Connector
ATX2, CN19	CPU Power Input Connector
COM1	COM port Connector
FAN1~3, FAN6	System Fan Connectors
FAN5	CPU Fan Connector
USB1	Internal USB2.0 Type A Connector
USB2	Internal USB2.0 Headers
USB3	Internal USB2.0 Headers
USB4	Internal USB2.0 Headers
Slot1, Slot5, Slot7	PCI-Express x8 Slots (Gen3)
Slot2, Slot4	PCI-Express x16 Slots (Gen4)
Slot6	PCI-Express x16 Slots (Gen3)
SATA1~SATA6	SATA III Connector
JP3	LAN1 Active LED Connector
JP10	LAN2 Active LED Connector
JP4	Programmable LED Connector
PS1	PS/2 Connector
HDA1	Audio Connector for AX93242
DIMM1~DIMM6	DDR4 RDIMM Connector

### 1.7.1 VGA Connector (CN1)

The 15-pin D-Sub connector is commonly used for VGA display.

Pin	Signal	Pin	Signal
1	Red	2	Green
3	Blue	4	NC
5	GND	6	GND
7	GND	8	GND
9	VCC	10	GND
11	NC	12	DDC DATA
13	Horizontal Sync	14	Vertical Sync
15	DDC CLK		

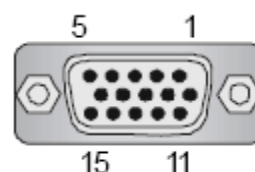

### 1.7.2 LAN and USB 3.1 Connectors (CN3 and CN4)

The motherboard comes with two high performance plug and play Ethernet interfaces (RJ-45) which are fully compliant with the IEEE 802.3 standard. Connection can be established by plugging one end of the Ethernet cable into this RJ-45 connector and the other end to a 1000/100/10 Base-T hub.

The Universal Serial Bus (compliant with USB 3.1 Gen2 (CN3) or USB3.1 Gen1 (CN4)) connectors on the rear I/O are used for installing USB peripherals such as a keyboard, mouse, scanner, etc.

Pin	LAN Signal	Pin	LAN Signal
L1	Tx+ (Data transmission positive)	L2	Tx- (Data transmission negative)
L3	Rx+ (Data reception positive)	L4	RJ-1 (For 1000 Base-T only)
L5	RJ-1 (For 1000 Base-T only)	L6	Rx- (Data reception negative)
L7	RJ-1 (For 1000 Base-T only)	L8	RJ-1 (For 1000 Base-T only)
A	100 LAN LED (Green) / 1000 LAN LED (Orange)	B	Active LED

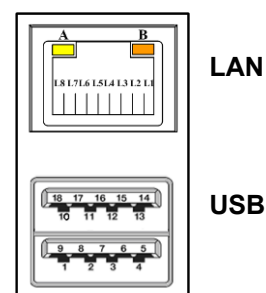

### 1.7.3 External Sensor Header (CN5)

The external sensor header is an 1x2-pin p=2.54mm header. The function of CN5 is to connect an external sensor.

Pin	Signal
1	Sys_Temp
2	GND

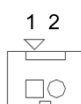

### 1.7.4 GPIO Header (CN6)

This header (5x2-pin p=2.00mm) is for digital I/O interface.

Pin	Signal	Pin	Signal
1	DIO1	2	DIO8
3	DIO2	4	DIO7
5	DIO3	6	DIO6
7	DIO4	8	DIO5
9	NC	10	GND

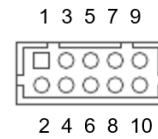

Note

*The default value of DIO1 to DIO8 is set as GPI with high level.*

### 1.7.5 TPM Pin Header (CN11)

These are 7x2-pin p=2.0mm headers for SPI interface with an AX93515 TPM module.

Pin	Signal	Pin	Signal
1	VCC3P3	2	GND
3	MOSI	4	MISO
5	CLK	6	CS2
7	RST	8	PIRQ
9	PP	10	NC
11	NC	12	NC
13	NC	14	MC

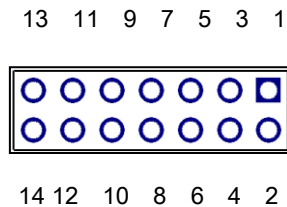

Note

*The screw type is M2\*0.4.*

### 1.7.6 M.2 2280 Key M PCIe x4 SSD slot (CN12)

The iHPC300 comes with one M.2 2280 Key M slot with PCIe x4 signal for NVMe SSD storage.

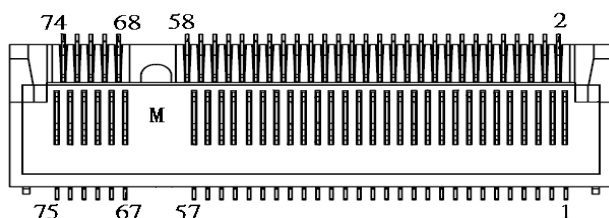

Pin	Signal	Pin	Signal	Pin	Signal	Pin	Signal
1	GND	2	+3.3V	3	GND	4	+3.3V
5	PEX3_RX-	6	NC	7	PEX3_RX+	8	NC
9	GND	10	LED_1#	11	PEX3_TX-	12	+3.3V
13	PEX3_TX+	14	+3.3V	15	GND	16	+3.3V
17	PEX2_RX-	18	+3.3V	19	PEX2_RX+	20	NC
21	GND	22	NC	23	PEX2_TX-	24	NC
25	PEX2_TX+	26	NC	27	GND	28	NC
29	PEX1_RX-	30	NC	31	PEX1_RX+	32	NC
33	GND	34	NC	35	PEX1_TX-	36	NC
37	PEX1_TX+	38	M.2_DEVSLP	39	GND	40	NC
41	PEX0_RX-	42	NC	43	PEX0_RX+	44	NC
45	GND	46	NC	47	PEX0_TX-	48	NC
49	PEX0_TX+	50	PERST#	51	GND	52	CLKREQ#
53	PEX0_REFCLKn	54	PEWAKE#	55	PEX0_REFCLKp	56	NC
57	GND	58	NC	59	CONNECTOR Key M	60	CONNECTOR Key M
61	CONNECTOR Key M	62	CONNECTOR Key M	63	CONNECTOR Key M	64	CONNECTOR Key M
65	CONNECTOR Key M	66	CONNECTOR Key M	67	NC	68	NC
69	NC	70	+3.3V	71	GND	72	+3.3V
73	GND	74	+3.3V	75	GND		

### 1.7.7 SMBus Header (CN14)

The CN14 (5x1-pin p=2.00mm) is for SMBus (System Management Bus) interface.

Pin	Signal	Pin	Signal
1	SMB_SCL	2	N/C
3	GND	4	SMB_SDA
5	+5V		

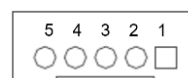

### 1.7.8 Voltage Monitor Header (CN15)

CN27 (8x1-pin p=2.54mm) is used for voltage monitoring and doesn't supply power.

Pin	Signal	Pin	Signal
1	GND	2	GND
3	VCC5_SB	4	+3.3V
5	-5V	6	+5V
7	-12V	8	+12V

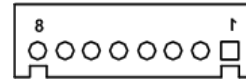

### 1.7.9 Front Panel Header (CN16)

This is a front panel header (7x2-pin p=2.54mm).

Pin	Signal
1	Power LED+
2	SPK- [*]
3	GND
4	BUZZER
5	Power LED-
6	N/C
7	N/C
8	SPK+ [*]
9	PWR-
10	PWR+
11	RESET-
12	RESET+
13	HD LED-
14	HD LED+

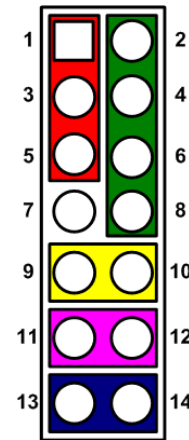

Note

[\*]: The buzzer on the motherboard will be active when pin 2 and pin 4 are connected; the external speaker on the chassis will be active when pin 2 and pin 4 are open.

### 1.7.10 Power Input Connectors (ATX1, ATX2, CN18 and CN19)

Steady and sufficient power can be supplied to all components on the motherboard by connecting the power connector. Please make sure all components and devices are properly installed before connecting the power connector.

An external power supply plug fits into ATX1/2 and CN18/19 in only one orientation. Properly press down the power supply plug until it completely and firmly fits into the connector. Loose connection may cause system instability.

ATX2 CPU power input connector:

Pin	ATX2 Signal	Pin	ATX2 Signal
1	GND	3	+12V
2	GND	4	+12V



CN19 CPU power input connector:

Pin	ATX2 Signal	Pin	ATX2 Signal
1	GND	5	+12V
2	GND	6	+12V
3	GND	7	+12V
4	GND	8	+12V

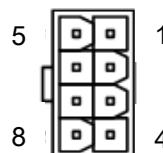

ATX1 ATX 12V power input connector:

Pin	ATX2 Signal	Pin	ATX2 Signal
1	GND	3	+12V
2	GND	4	+12V



CN18 24-pin ATX power input connector:

Pin	CN26 Signal	Pin	CN26 Signal
1	3.3V	13	3.3V
2	3.3V	14	-12V
3	GND	15	GND
4	+5V	16	PS_ON
5	GND	17	GND
6	+5V	18	GND
7	GND	19	GND
8	PWR OK	20	-5V
9	5VSB	21	+5V
10	+12V	22	+5V
11	+12V	23	+5V
12	3.3V	24	GND

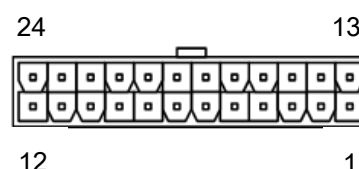

### 1.7.11 Internal USB 3.1 Gen1 Connector (CN20)

The CN20 is a 19-pin internal connector for installing versatile USB 3.1 compliant peripherals.

Pin	Signal	Pin	Signal
1	VBUS0		
2	SSRX5-	19	VBUS1
3	SSRX5+	18	SSRX6-
4	GND	17	SSRX6+
5	SSTX5-	16	GND
6	SSTX5+	15	SSTX6-
7	GND	14	SSTX6+
8	USB10-	13	GND
9	USB10+	12	USB11-
10	ID	11	USB11+

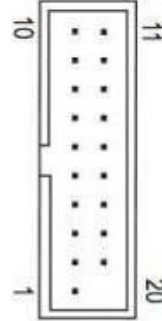

### 1.7.12 COM1 Connector (COM1)

This is a high rise 9-pin D-Sub connector for COM1 serial port interface. The pin assignments of RS-232/422/485 are listed in the table below.

Pin	RS-232 [1]	RS-422 [1]	RS-485 [1]
1	DCD#	TX-	485-
2	RXD	TX+	485+
3	TXD	RX+	N/C
4	DTR#	RX-	N/C
5	GND	GND	GND
6	DSR#	N/C	N/C
7	RTS#	N/C	N/C
8	CTS#	N/C	N/C
9	RI#	N/C	N/C

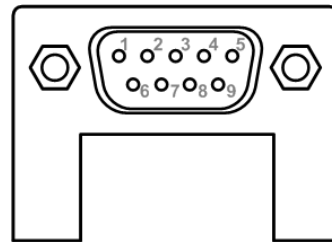

**Note**

[1]: COM1 can be used for RS-232/422/485 signals through BIOS settings.

### 1.7.13 Fan Connectors (FAN1~FAN3 and FAN5~6)

This motherboard has five fan connectors. Find fan speed option(s) at BIOS Setup Utility: Advanced\HW Monitor\PC Health Status.

FAN1~3 and FAN6 (4x1-pin p=2.54mm) are used for the system fan connectors. FAN 5 (4x1-pin p=2.54mm) is used for the CPU fan connector.

Pin	Signal
1	GND
2	+12V
3	FAN Speed Detection
4	FAN Speed Control



### 1.7.14 Internal USB Headers (USB1~4)

USB 2~4 are 5x2-pin p=2.54mm headers for USB 2.0 interface.

Pin	Signal	Pin	Signal
1	+5 V_DUAL	2	+5 V_DUAL
3	USB 5, 7, 12-	4	USB 6, 8, 13-
5	USB 5, 7, 12+	6	USB 6, 8, 13+
7	GND	8	GND
		10	GND

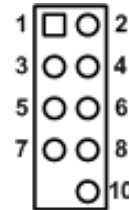

USB 1 is a Type-A 180D connector for USB2.0 signal.

Pin	Signal
1	+5V_DUAL
2	USB-
3	USB+
4	GND

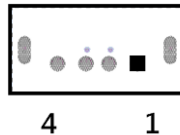



### 1.7.15 SATA 3.0 Connectors (SATA1 ~ SATA6)

These Serial Advanced Technology Attachment (Serial ATA or SATA) connectors are for SATA 3.0 interface allowing up to 6.0Gb/s data transfer rate. It is a computer bus interface for connecting to devices such as a hard disk drive.

Pin	Signal
1	GND
2	SATA_TX+
3	SATA_TX-
4	GND
5	SATA_RX-
6	SATA_RX+
7	GND

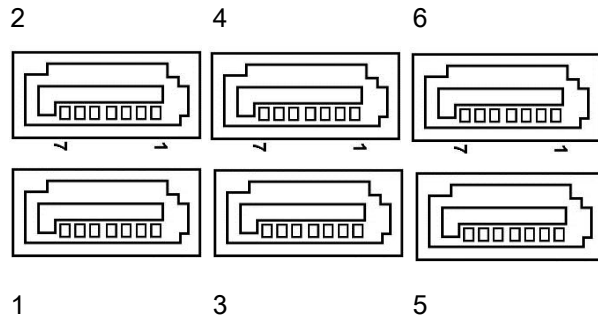

### 1.7.16 LAN Active LED connectors (JP3 and JP10)

There are two LAN active LED connectors for the front panel (2x1-pin p=2.54mm).

JP 3 is for active LED.

JP 10 is for LAN2 active LED.

Pin	Signal
1	P3V3_AUX
2	L1_LINK/ACT#

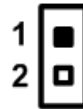

### 1.7.17 Programmable LED connectors (JP4)

JP 4 is for the programmable LED connector (2x1-pin p=2.54mm).

Pin	Signal
1	P3V3_AUX
2	L1_LINK/ACT#



### 1.7.18 Keyboard and PS/2 Mouse Connector (PS1)

The board supports a keyboard and mouse interface. Connector CN is a DIN connector for PS/2 keyboard connection via a Y-Cable.

Pin	Signal
1	Keyboard Data
2	Mouse Data
3	GND
4	VCC
5	Keyboard Clock
6	Mouse Clock

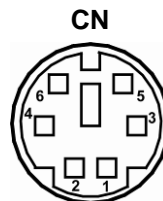

### 1.7.19 Intel® HD Audio Digital Header (HDA1)

This is a 2x8-pin header for connecting an external HD Audio board (AX93242).

Pin	Signal	Pin	Signal
1	BCLK	2	GND
3	RST#	4	N.C
5	SYNC	6	GND
7	SDO	8	+3.3S
9	SDIO	10	+12VS
11	N.C	12	
13	N.C	14	N.C
15	N.C	16	GND

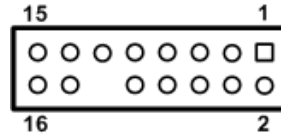

## Section 2

# Hardware Installation

This section provides information on how to install the iHPC300. The iHPC300 is convenient for your various hardware configurations. Chapter 2 will show you how to install these hardware parts.

### 2.1 Installing the CPU

The LGA4189 processor socket comes with a cover to protect the processor. Please install the processor into the CPU socket step by step as illustrated below. There are two cooler modules as shown in the following pictures:

This cooler is for CPU.

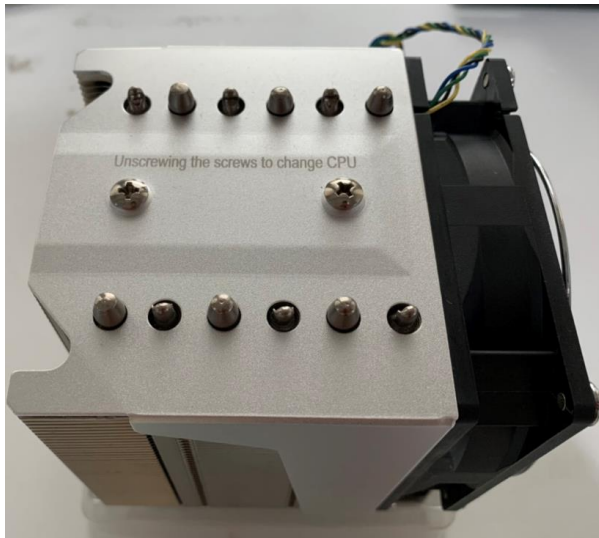

This sequence is for installing the CPU cooler:

**Step 1** Remove the socket protective covers. Press the load lever and release it from the retention tab. There are two levers for each CPU socket.

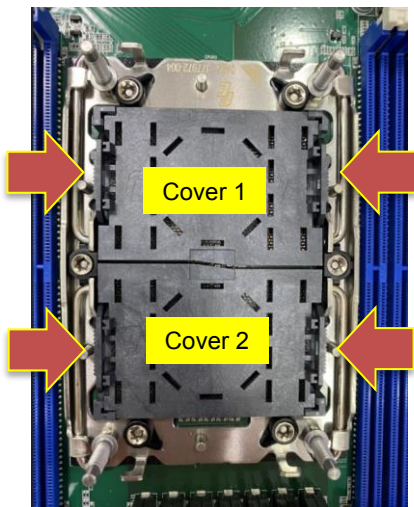

**Step 2** Insert the CPU onto the CPU clip and align notch A to D on the CPU clip, then latch pin 1 to 4.

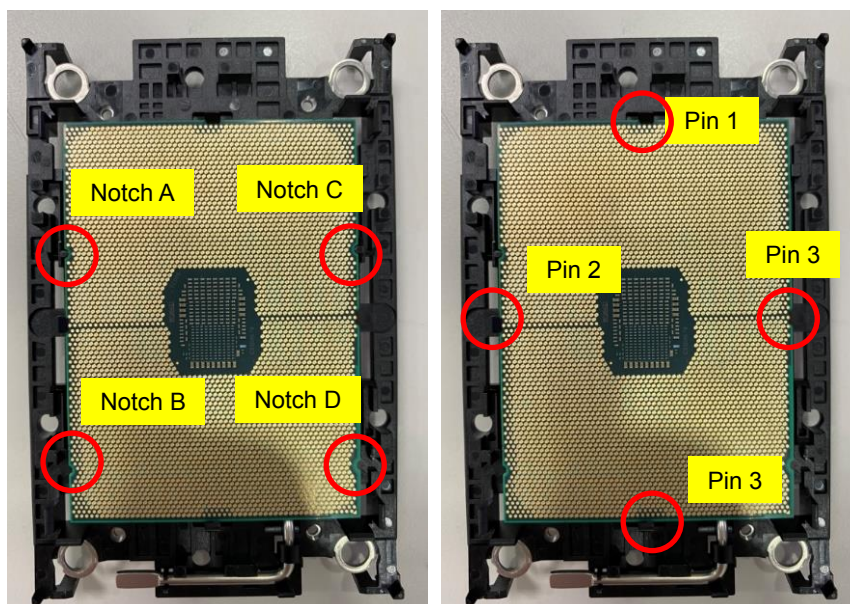

**Step 3** Check the notch on the CPU and the pin on the CPU socket of iHPC300.

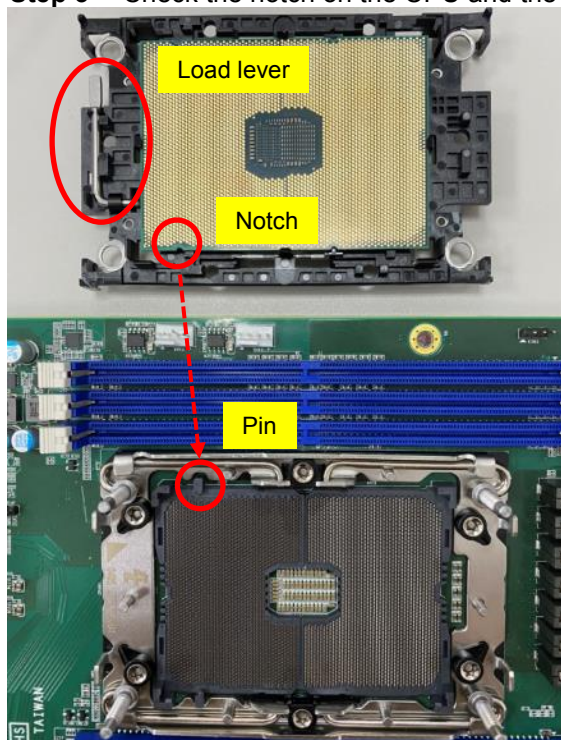

Follow the installation direction and Install the CPU clip and CPU on the cooler module.

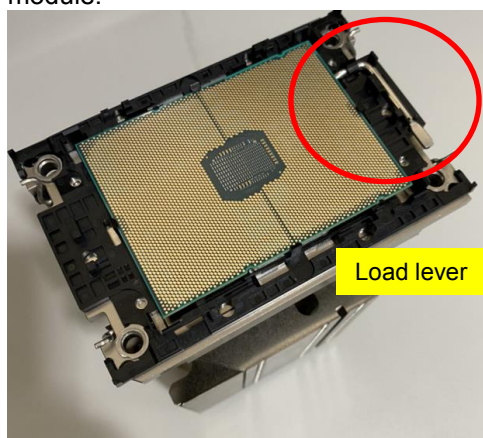

**Step 4** Place the CPU cooler module on the CPU socket on the motherboard, and then align pin A to hole A and pin B to hole B simultaneously.

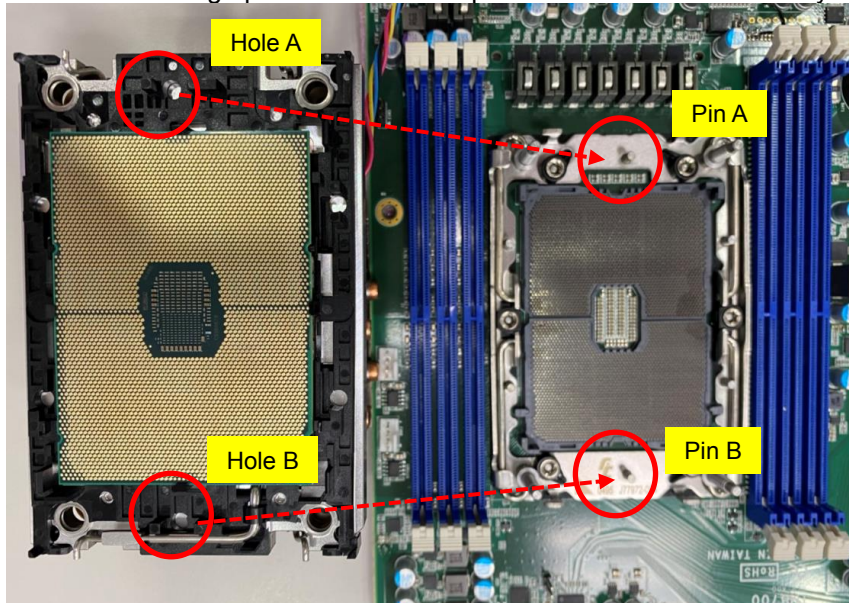

**Note**

*The installation direction of CPU on the clip and cooler module can affect how the air flows through chassis. Please follow the installing instructions to ensure that the CPU is properly installed for best cooling performance.*

**Step 5** Use a T30 Torx screwdriver (8in-LBF) to tighten the screws and press down the four levers on the cooler.

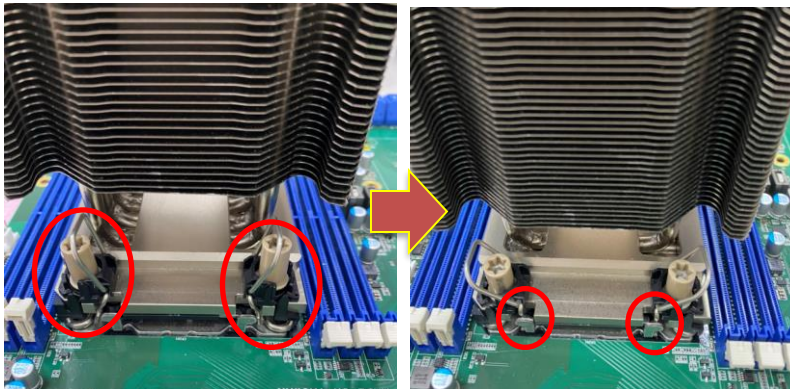
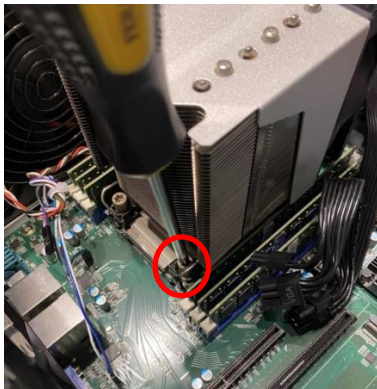

**Step6** Put the fan module on the CPU cooler and tighten two screws (8in-LBF).

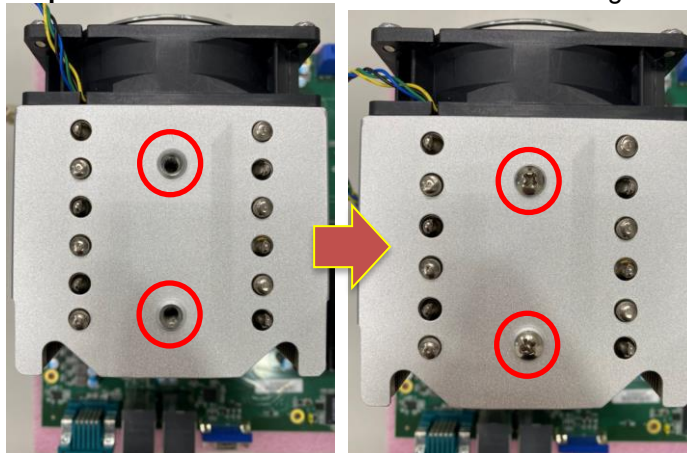

## 2.2 Installing the Memory

The system supports six 288-pin DDR4 RDIMM memory sockets with maximum memory capacity up to 384GB.

Please follow steps below to install the memory modules:

1. Push down the latches on each side of the DIMM socket.
2. Align the memory module with the socket. For correct installation, the notches of the memory module must match the socket keys.
3. Install the memory module into the socket and push it firmly down until it is fully seated. The socket latches are levered upwards and clipped on to the edges of the DIMM.
4. Install any remaining DIMM modules by repeating the above steps.

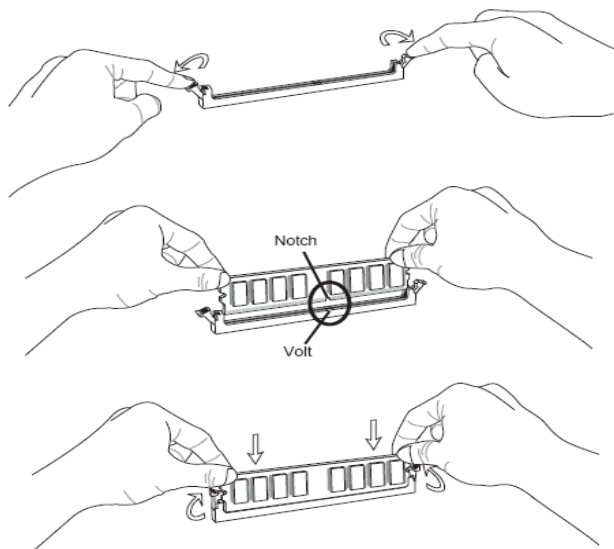

**This page is intentionally left blank.**



## Section 3

# AMI BIOS Setup Utility

The AMI UEFI BIOS provides users with a built-in setup program to modify basic system configuration. All configured parameters are stored in a flash chip to save the setup information whenever the power is turned off. This chapter provides users with detailed description about how to set up basic system configuration through the AMI BIOS setup utility.

### 3.1 Starting

To enter the setup screens, follow the steps below:

1. Turn on the computer and press <Del> during the Power On Self Test (POST) to enter BIOS setup, otherwise, POST will continue with its test routines.
2. Once you enter the BIOS, the main BIOS setup menu displays. You can access the other setup screens from the main BIOS setup menu, such as the Advanced and Chipset menus.



**Note**

*If your computer cannot boot after making and saving system changes with BIOS setup, you can restore BIOS optimal defaults by setting JP8 (see section 2.4.1).*

It is strongly recommended that you should avoid changing the chipset's defaults. Both AMI and your system manufacturer have carefully set up these defaults that provide the best performance and reliability.

### 3.2 Navigation Keys

The BIOS setup/utility uses a key-based navigation system called hot keys. Most of the BIOS setup utility hot keys can be used at any time during the setup navigation process. These keys include <F1>, <F2>, <Enter>, <ESC>, <Arrow> keys, and so on.



**Note**

*Some of the navigation keys differ from one screen to another.*

<b>Hot Keys</b>	<b>Description</b>
<b>→← Left/Right</b>	The Left and Right <Arrow> keys allow you to select a setup screen.
<b>↑↓ Up/Down</b>	The Up and Down <Arrow> keys allow you to select a setup screen or sub screen.
<b>Enter</b>	The <Enter> key allows you to display or change the setup option listed for a particular setup item. The <Enter> key can also allow you to display the setup sub screens.
<b>+– Plus/Minus</b>	The Plus and Minus <Arrow> keys allow you to change the field value of a particular setup item.
<b>F1</b>	The <F1> key allows you to display the General Help screen.
<b>F2</b>	The <F2> key allows you to Load Previous Values.
<b>F3</b>	The <F3> key allows you to Load Optimized Defaults.
<b>F4</b>	The <F4> key allows you to save any changes you have made and exit Setup. Press the <F4> key to save your changes.
<b>Esc</b>	The <Esc> key allows you to discard any changes you have made and exit the Setup. Press the <Esc> key to exit the setup without saving your changes.

### 3.3 Main Menu

When you first enter the setup utility, you will enter the Main setup screen. You can always return to the Main setup screen by selecting the Main tab. System Time/Date can be set up as described below. The Main BIOS setup screen is shown below.

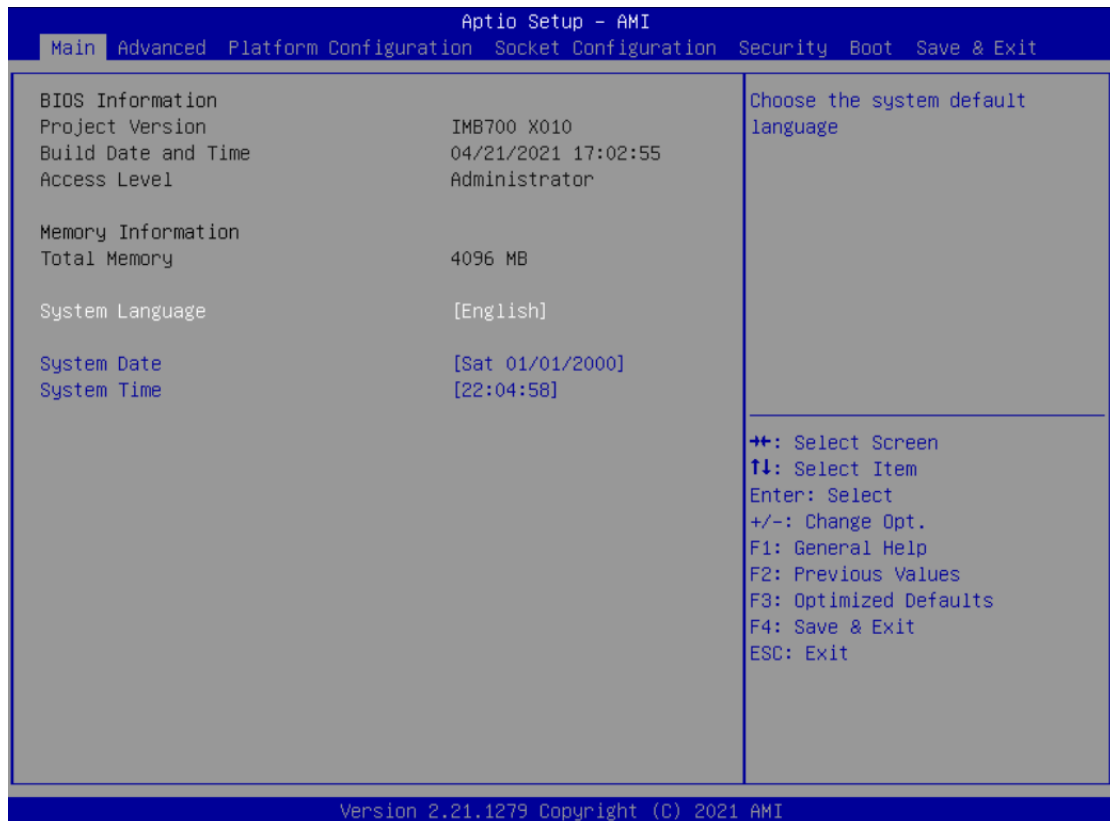

#### BIOS Information

Display the BIOS information.

#### Access Level

Display the access level of current user.

#### System Date/Time

Use this option to change the system time and date. Highlight System Time or System Date using the <Arrow> keys. Enter new values through the keyboard. Press the <Tab> key or the <Arrow> keys to move between fields. The date must be entered in MM/DD/YY format. The time is entered in HH:MM:SS format.

### 3.4 Advanced Menu

The Advanced menu also allows users to set configuration of the CPU and other system devices. You can select any of the items in the left frame of the screen to go to the sub menus:

- ▶ Trusted Computing
- ▶ F81803 Super IO Configuration
- ▶ Hardware Monitor
- ▶ NCT7802Y HW Monitor
- ▶ Serial Port Console Redirection
- ▶ PCI Subsystem Settings
- ▶ USB Configuration
- ▶ Network Stack Configuration
- ▶ CSM Configuration

For items marked with “▶”, please press <Enter> for more options.

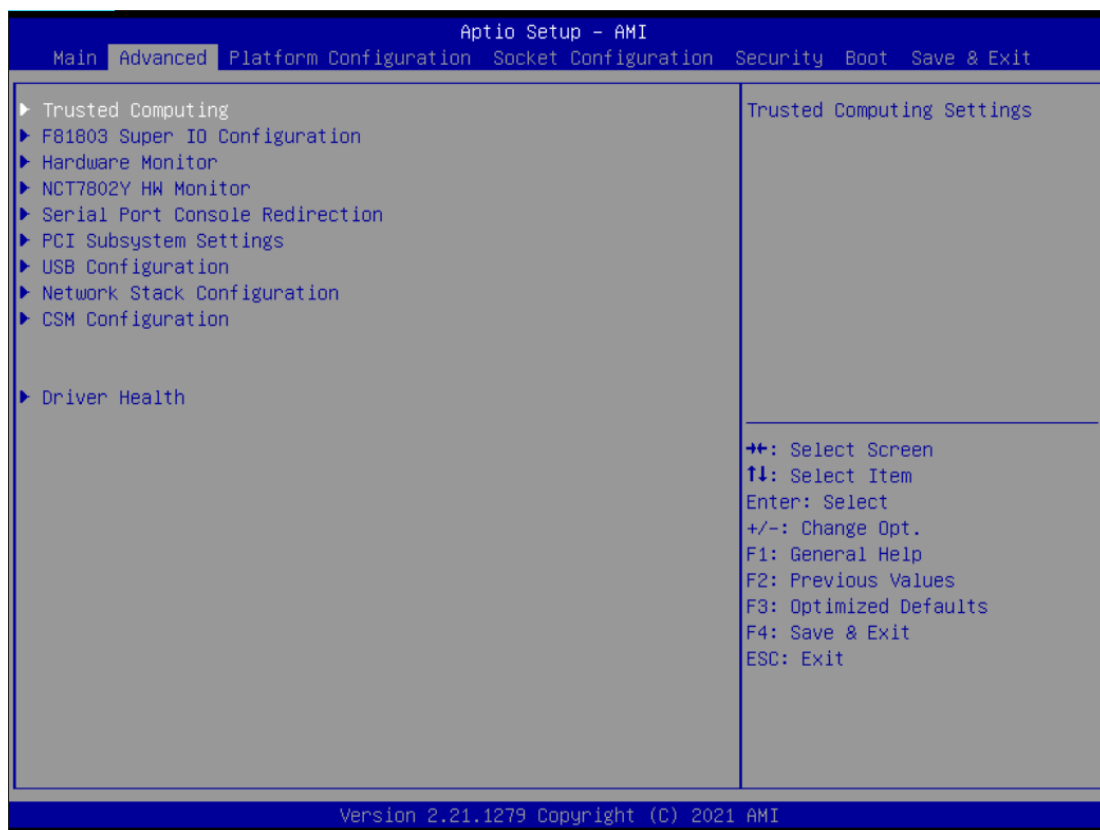

- **Trusted Computing**

Enable or disable security device support.



- **F81803 Super IO Configuration**

You can use this screen to select options for the Super IO Configuration, and change the value of the selected option. A description of the selected item appears on the right side of the screen. For items marked with “▶”, please press <Enter> for more options.

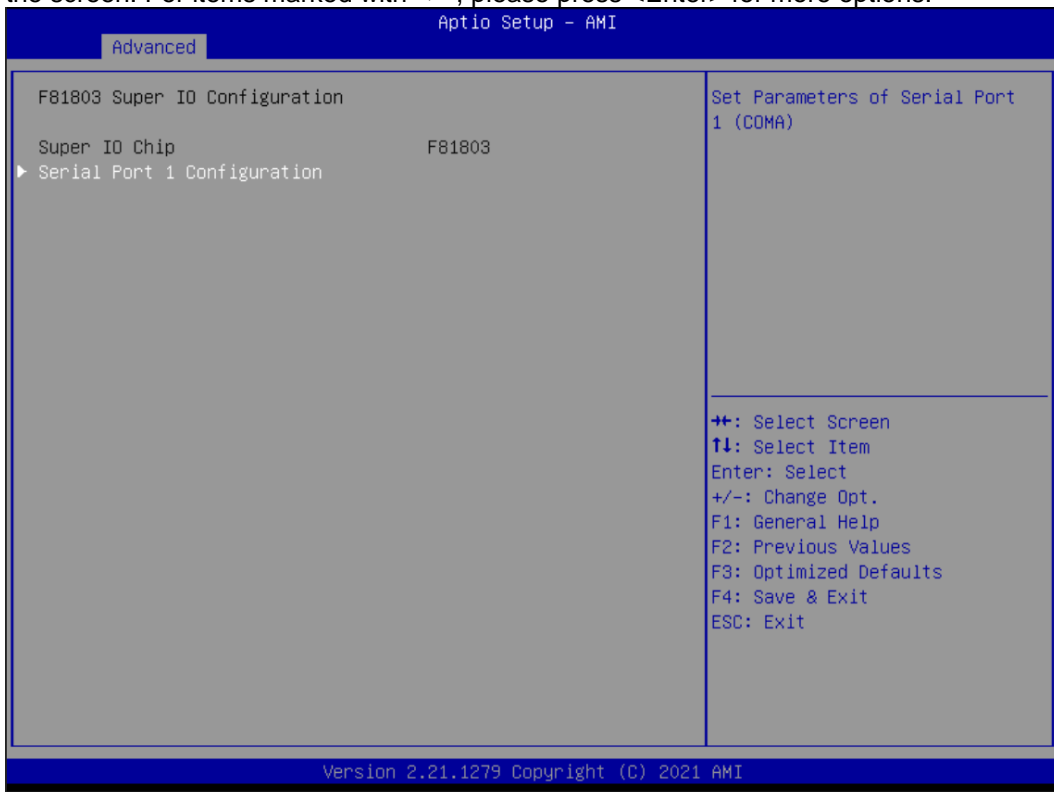

- **Hardware Monitor**

This screen monitors hardware health status.

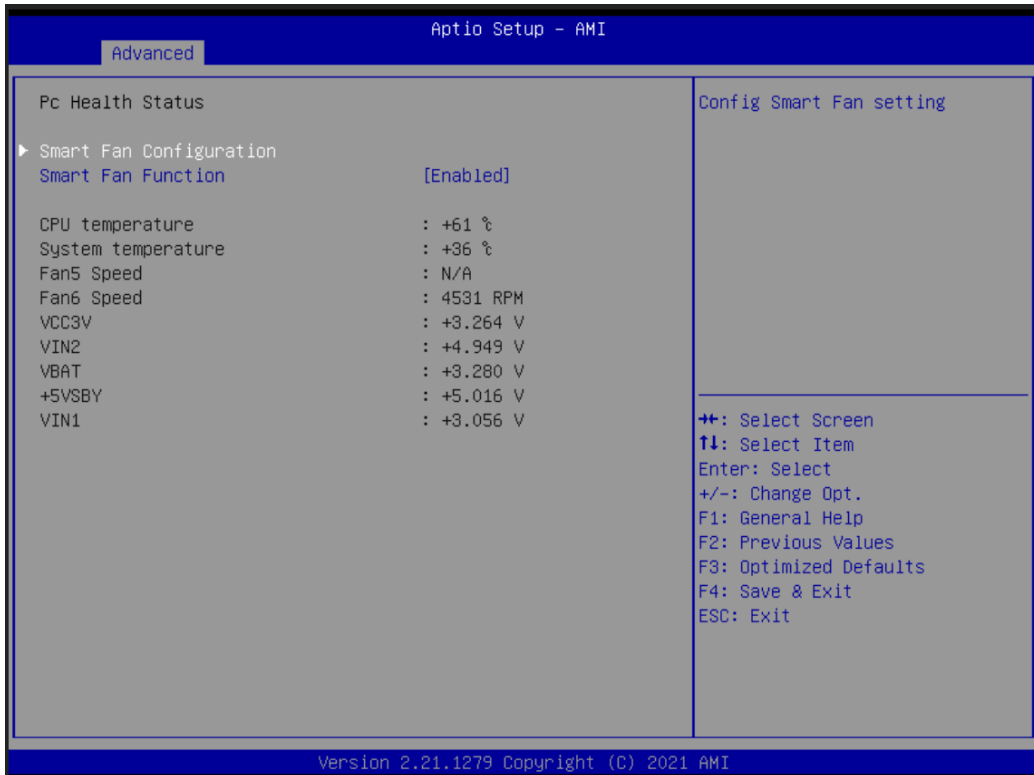

This screen displays the temperature of system and CPU, cooling fans speed in RPM and system voltages (VCC3V, VIN2, VBAT, +5VSBY and VIN1).



**Note**

**CPU FAN = FAN5; SYS FA = FAN6.**

- **NCT7802Y Hardware Monitor**

This screen monitors hardware health status.

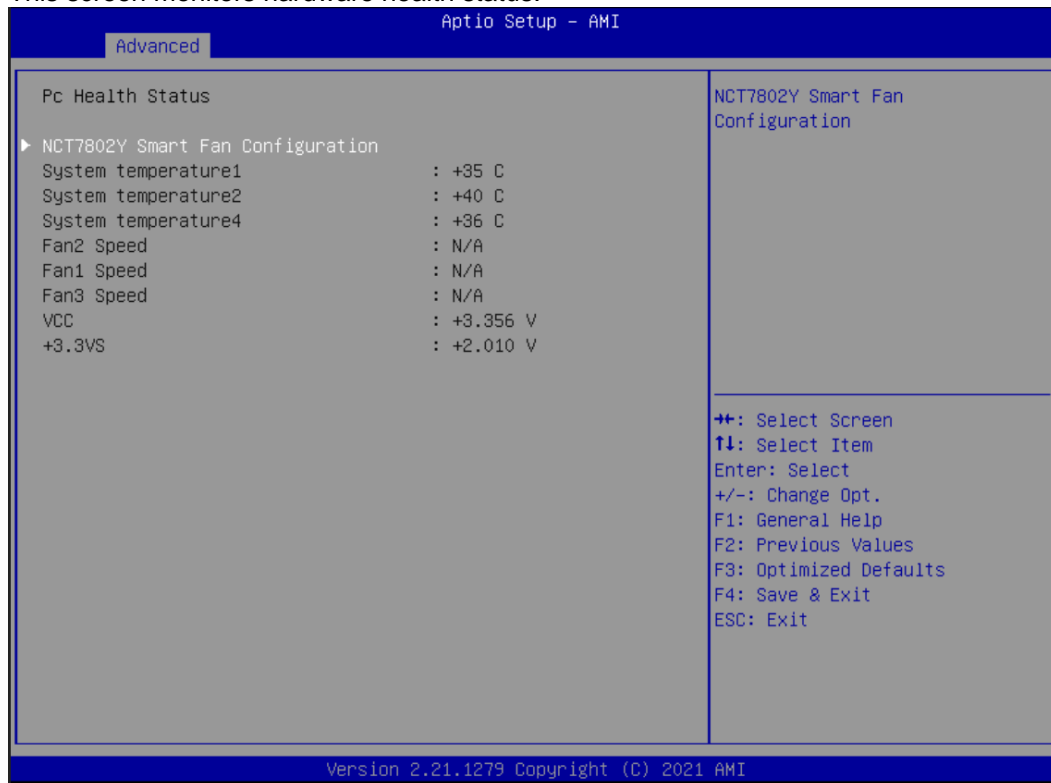

This screen displays the temperature of system, cooling fans speed in RPM and system voltages.



**SYS FA = FAN1, 2 & 3.**

**Note**



- **Serial Port Console Redirection**

This screen allows you to set serial port console redirection.

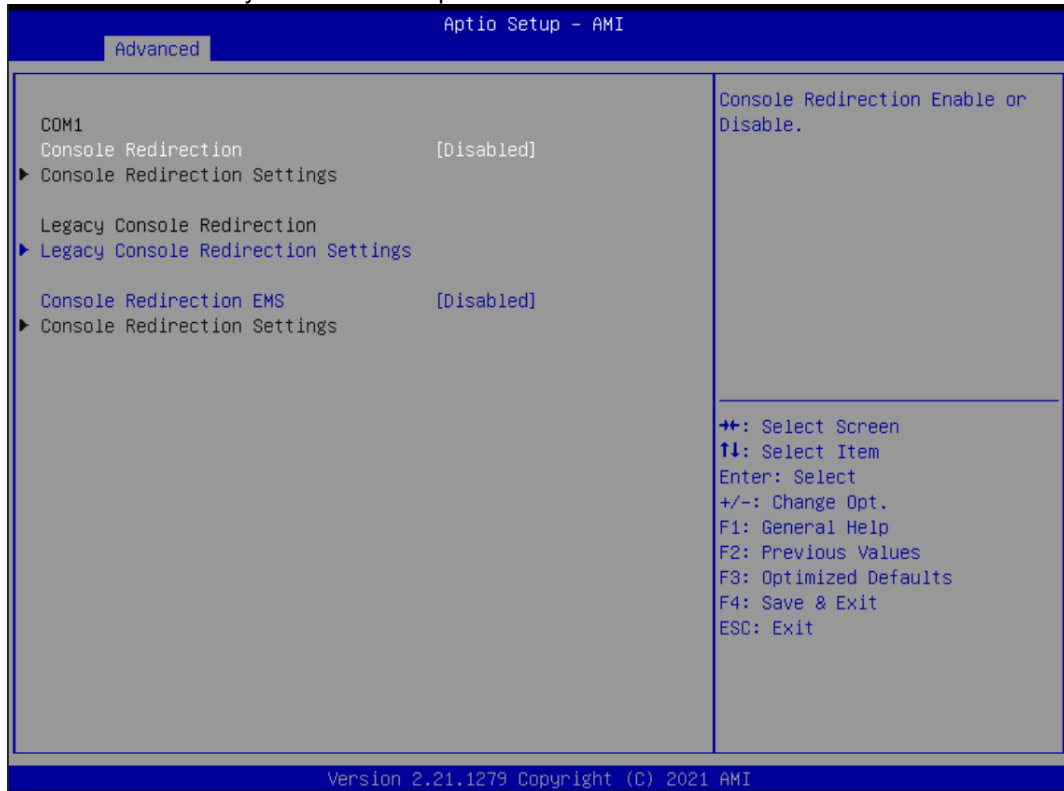

- **PCI Subsystem Settings**

This screen allows you to set PCI Subsystem mode.



**Above 4G Decoding**

Enable or disable above 4G decoding.

**SR-IOV Support**

Enable or disable SR-IOV support.

**BME DMA Mitigation**

Enable or disable BME DMA Mitigation.

- **USB Configuration**

This screen shows USB configuration.

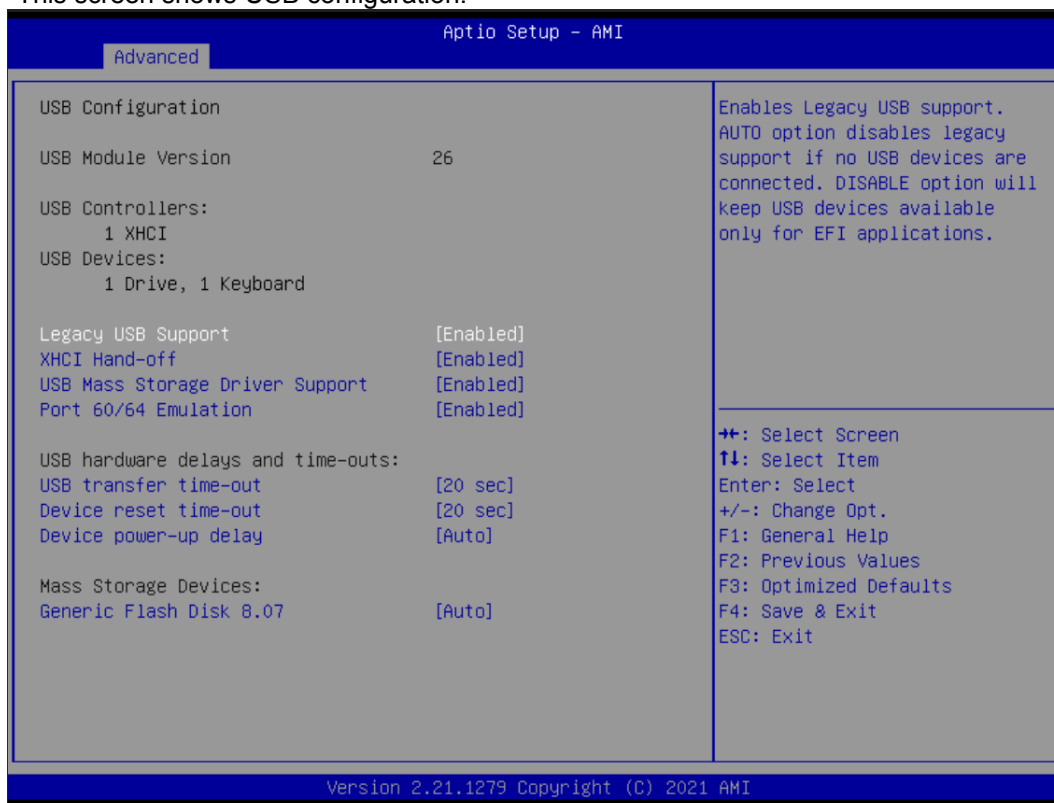

### USB Devices

Displays all detected USB devices.

### Legacy USB Support

Enables Legacy USB support. The AUTO option disables legacy support if no USB devices are connected.

### XHCI Hand-off

This is a workaround for OSES without XHCI hand-off support. The XHCI ownership change should be claimed by XHCI driver.

### USB Mass Storage Driver Support

Enable/Disable USB Mass Storage Driver Support.

### Port 60/64 Emulation

Enable/Disable port60/64 emulation.

### USB transfer time-out

The time-out value for Control, Bulk, and Interrupt transfers.

### Device reset time-out

USB mass storage device Start Unit command time-out. 待 BIOS RD 説明

### Device power-up delay

Maximum time the device will take before it properly reports itself to the Host Controller. 'Auto' uses default value: for a Root port it is 100 ms, for a Hub port the delay is taken from Hub descriptor.

- **Network Stack Configuration**

On this screen, you can select PXE LAN port.



- **CSM (Compatibility Support Module) Configuration**

This screen displays CSM information.



### CSM Support

Enabled / Disable CSM Support.

### GateA20 Active

UPON REQUEST - GA20 can be disabled using BIOS services. ALWAYS - do not allow disabling GA20. This option is useful when any RT code is executed above 1MB.

### Option ROM Messages

Set display mode for Option ROM.

### INT19 Trap Response

BIOS reaction on INT19 trapping by Option ROM: IMMEDIATE - execute the trap right away; POSTPONED - execute the trap during legacy boot.

### HDD Connection Order

OS requires HDD handles to be adjusted, i.e., OS is installed on driver.

### PCIe LAN IO Resource

The user can choose to disable or enable this function.

### Boot option filter

This option controls Legacy/UEFI ROMs priority.

### Network

Controls the execution of UEFI and Legacy Network OpROM.

### Storage

Controls the execution of UEFI and Legacy Storage OpROM.

**Video**

Controls the execution of UEFI and Legacy Video OpROM.

**Other PCI devices**

Determines OpROM execution policy for devices other than Network, Storage, or Video.

## 3.5 Platform Configuration

The Chipset menu allows users to change the advanced chipset settings. You can select any of the items in the left frame of the screen to go to the sub menus:

- ▶ PCH Configuration
- ▶ PCI Express Configuration
- ▶ PCH SATA Configuration
- ▶ Azalia Configuration

For items marked with “▶”, please press <Enter> for more options.

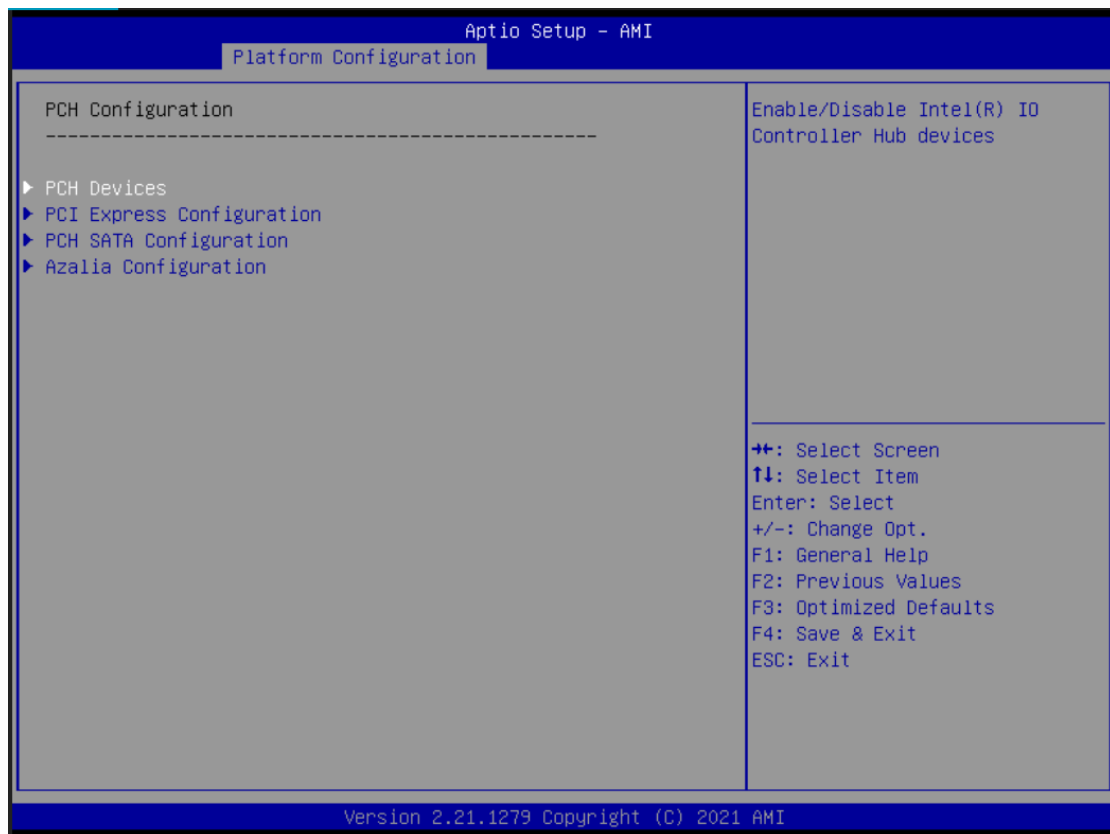

- **PCH Devices**

The screen shows PCH devices.

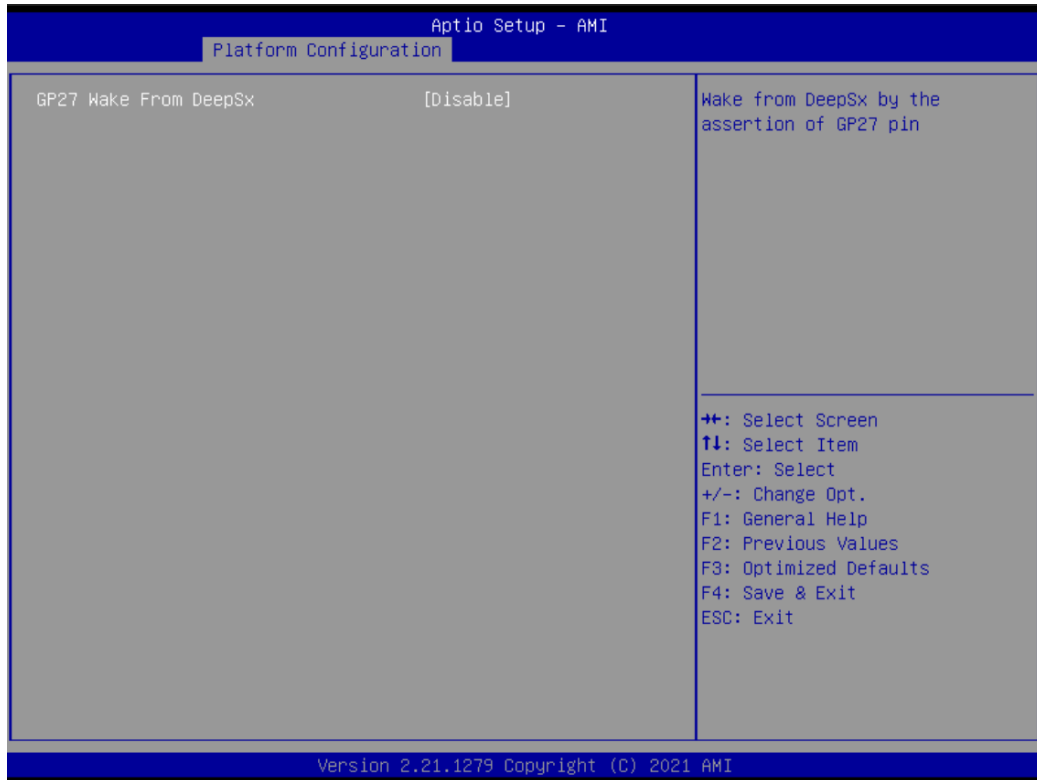

**Wake From DeepSx**

Enable or disable the GP27 Wake From DeepSx.



- **PCI Express Configuration**

The screen shows PCI Express Configuration.

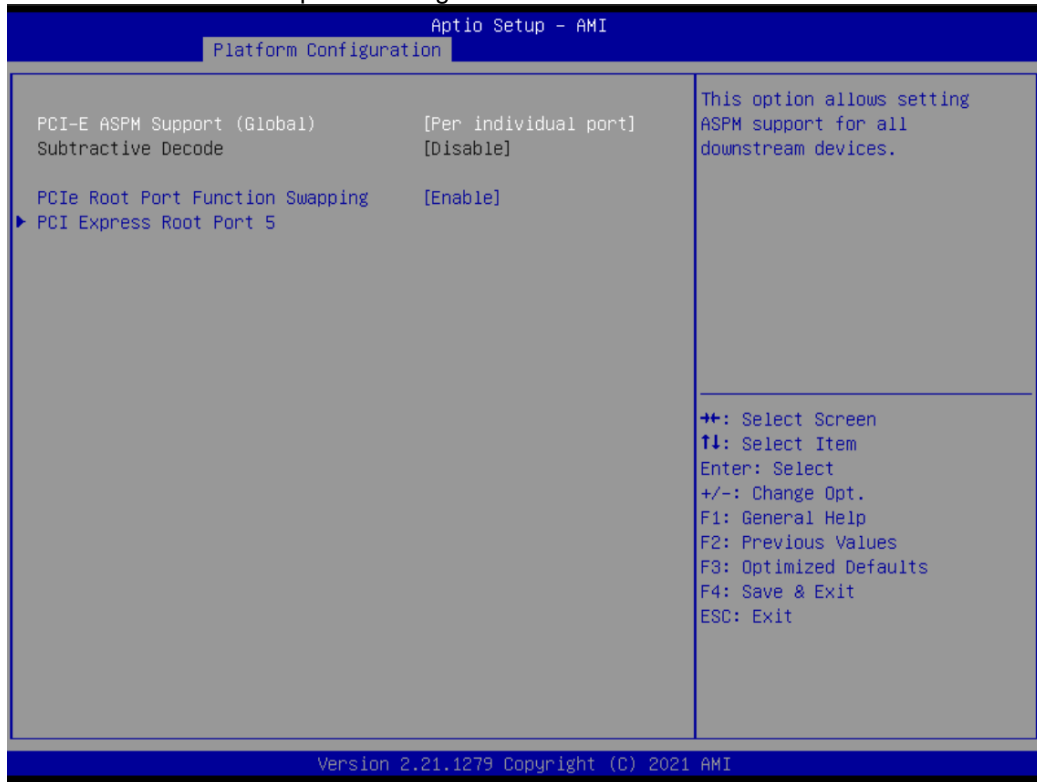

- **PCH SATA Configuration**

During system boot up, the BIOS automatically detects the presence of SATA devices. In the SATA Configuration menu, you can see the hardware currently installed in the SATA ports.

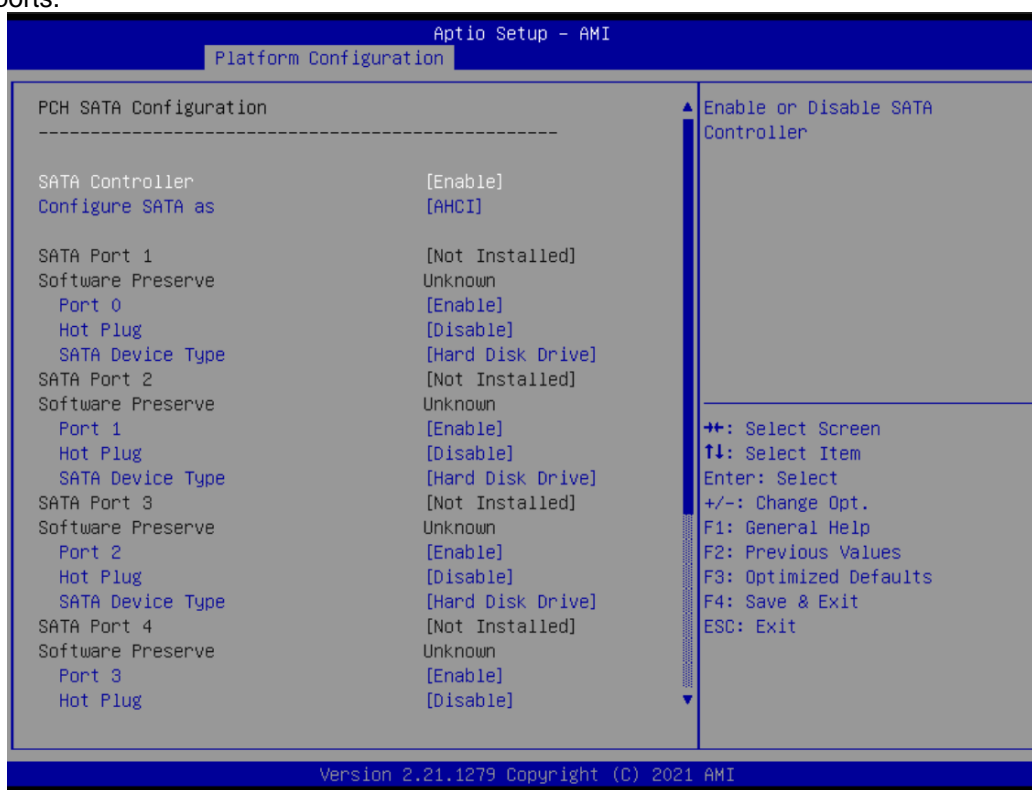

#### **SATA Controller(s)**

Enable or disable the SATA Controller feature. The default is Enabled.

#### **Configuration SATA as**

Determine how SATA controller(s) operate. Operation mode options are RAID and AHCI (Advanced Host Controller Interface). The default is the AHCI mode.

#### **Port**

Enable or disable the SATA port.

#### **Hot Plug**

Designates this port as Hot Pluggable.

#### **SATA Device Type**

Identify whether the SATA port is connected to a solid-state drive (SSD) or to a hard disk drive (HDD).

- **Azalia Configuration**

This screen shows Azalia configuration.

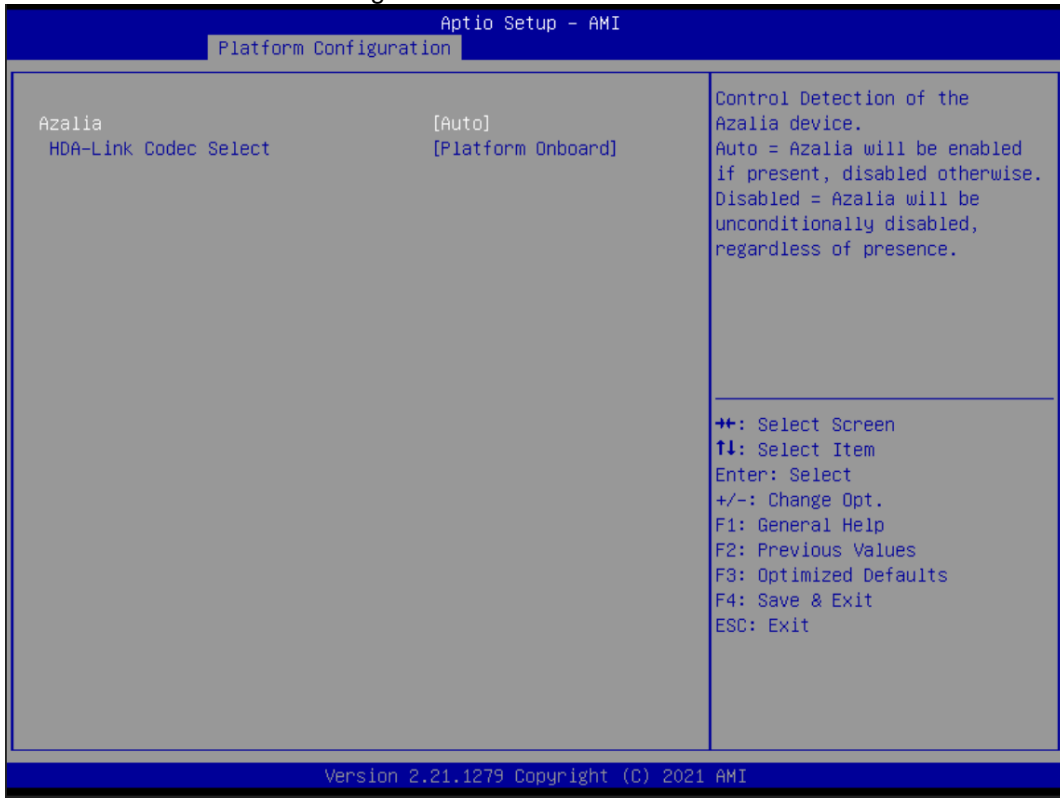

## 3.6 Socket Configuration

The socket configuration menu allows users to change the advanced socket settings.

- ▶ Processor Configuration
- ▶ IIO Configuration

For items marked with “▶”, please press <Enter> for more options.

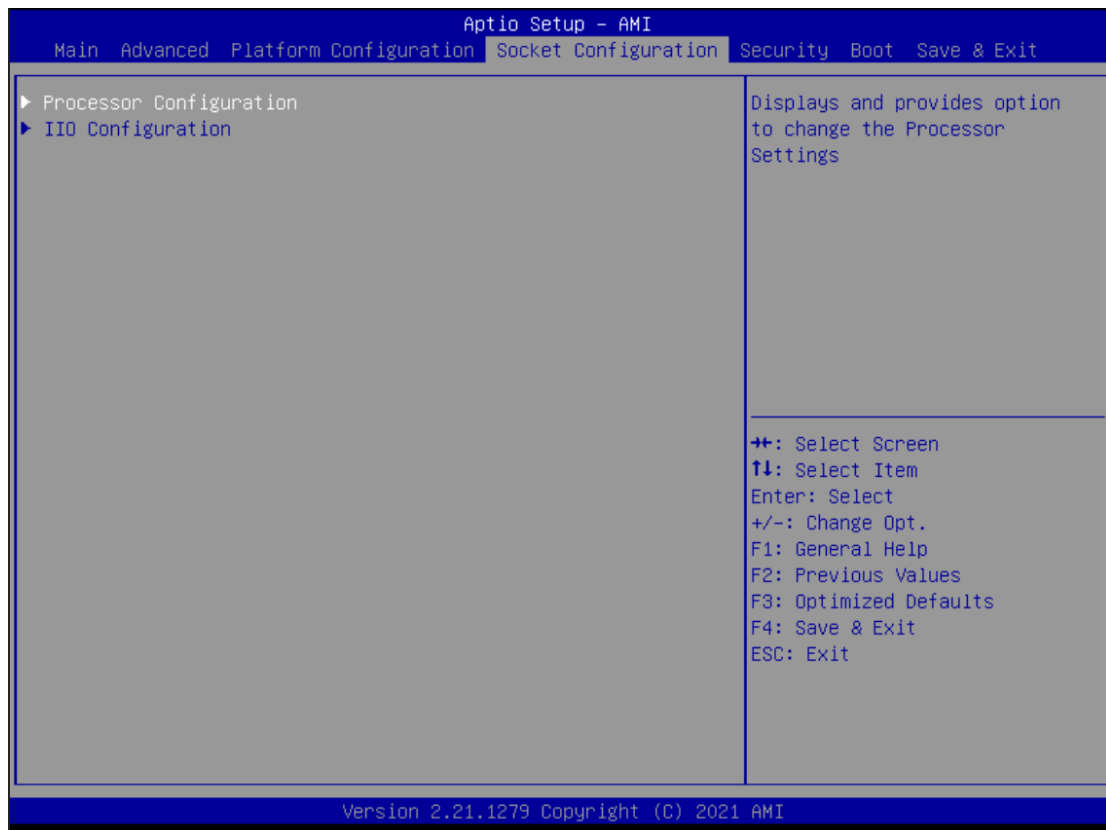

- **Processor Configuration**

This screen allows the user to view processor information and set TME function.

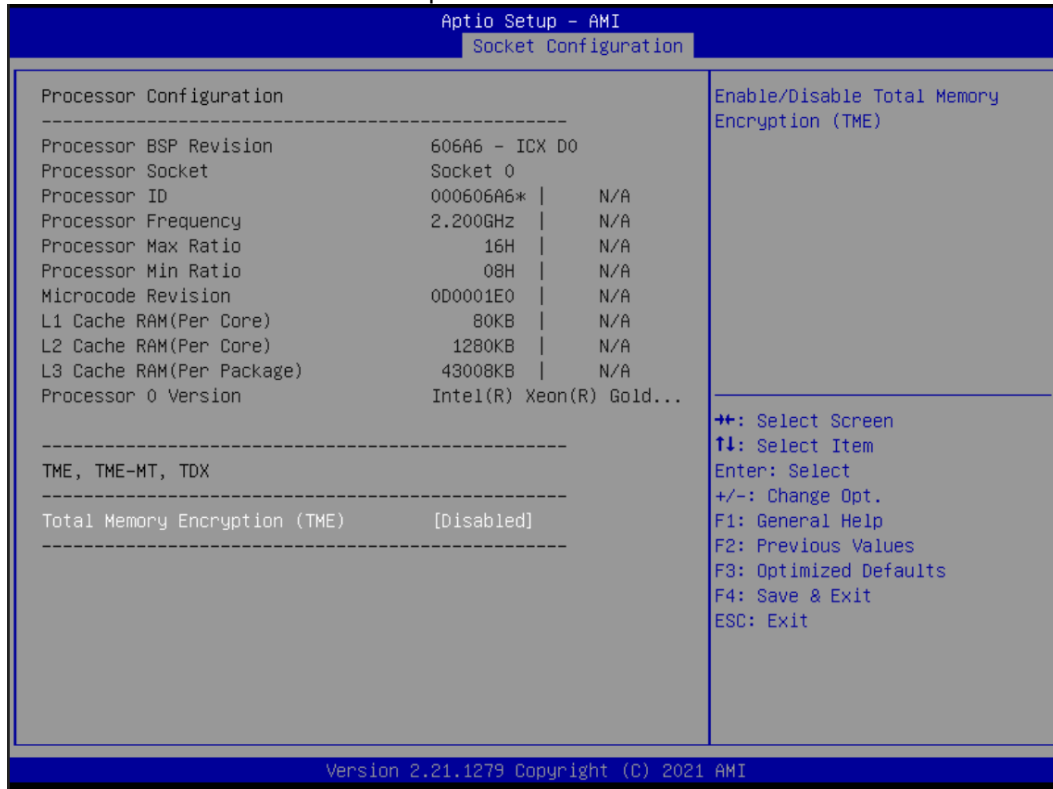

### Total Memory Encryption (TME)

Enable or disable the TME function.

- **I/O Configuration**

This screen shows the IO configuration information.

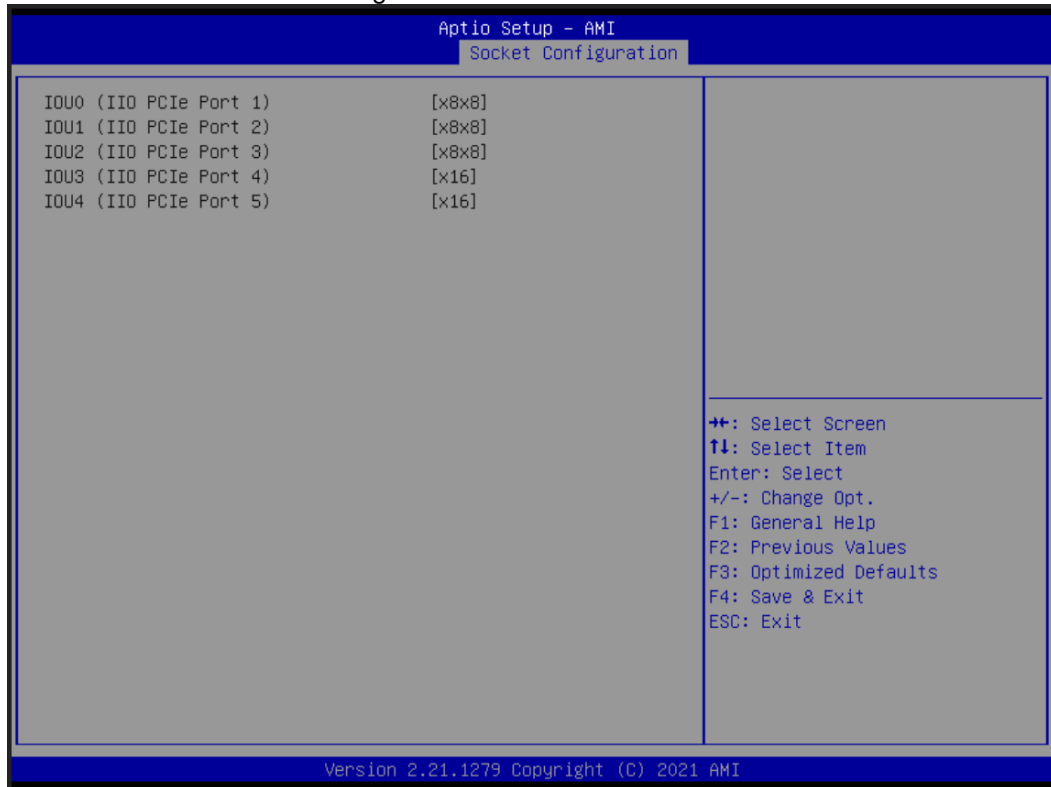

### 3.7 Security Menu

The Security menu allows users to change the security settings for the system.

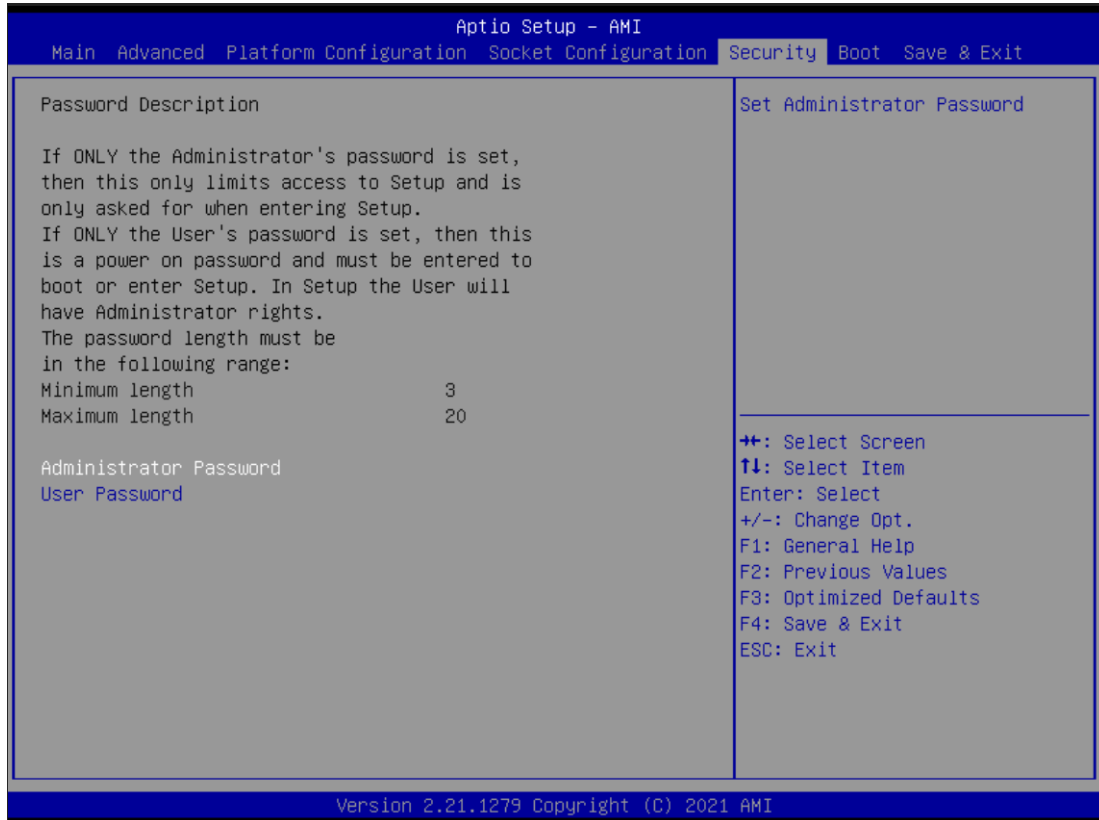

#### Administrator Password

This item indicates whether an administrator password has been set (installed or uninstalled).

#### User Password

This item indicates whether a user password has been set (installed or uninstalled).

## 3.8 Boot Menu

The Boot menu allows users to change boot options of the system.

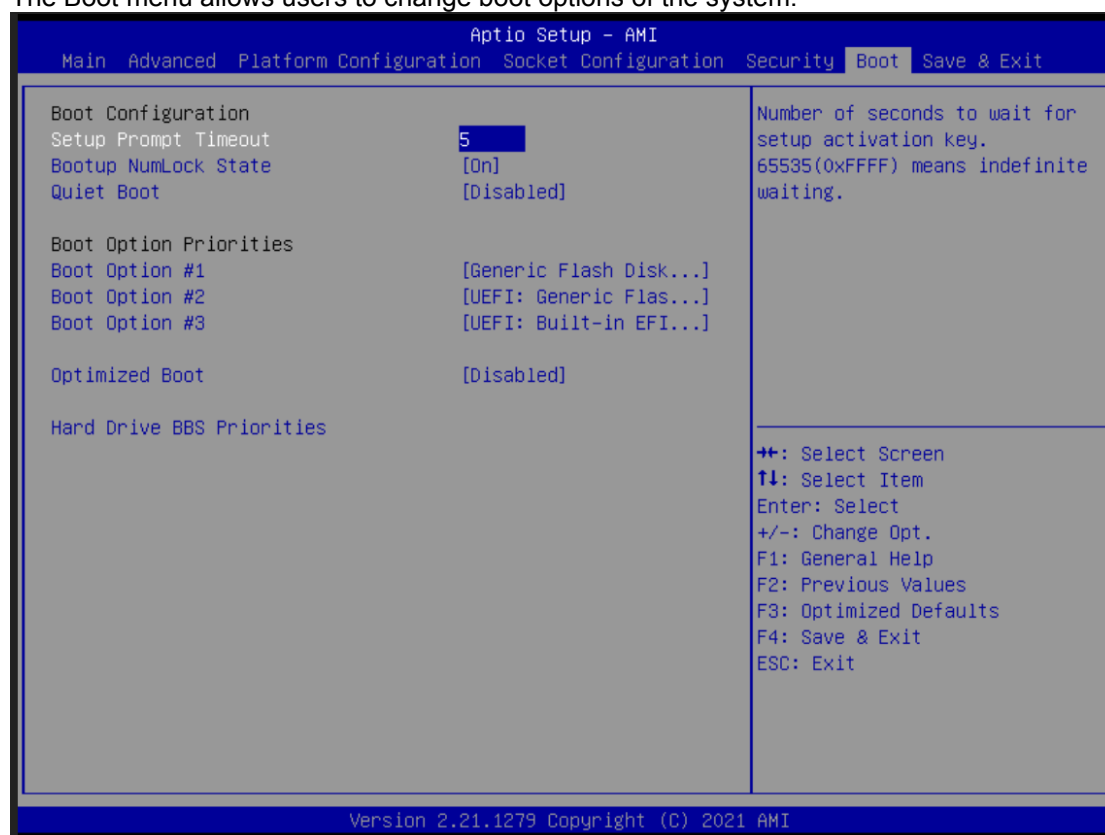

### Setup Prompt Timeout

Enter the number of seconds to wait for the setup activation key. 65535(0xFFFF) means indefinite waiting.

### Bootup NumLock State

Use this item to select the power-on state for the keyboard NumLock.

### Quiet Boot

Select to display either POST output messages or a splash screen during boot-up.

### Boot Option Priorities

These are settings for boot priority. Specify the boot device priority sequence from the available devices.

### Optimized Boot

When the system BIOS boots using native UEFI graphic drivers, use this function to control and enable compatibility with VMware ESXi on a system configured for UEFI Boot Mode, and to enable and use Secure Boot Mode.



### 3.9 Save & Exit Menu

The Save & Exit menu allows users to load your system configuration with optimal or fail-safe default values.

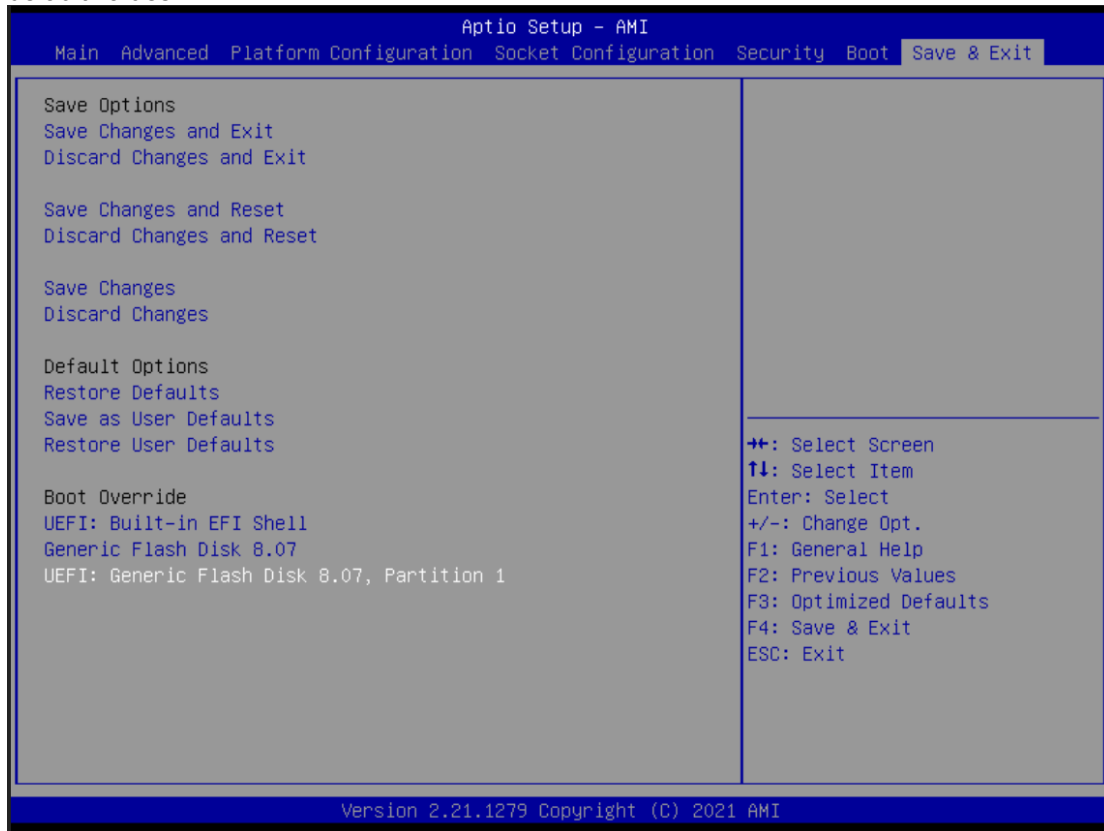

#### Save Changes and Exit

When you have completed the system configuration changes, select this option to leave Setup and return to Main Menu. Select Save Changes and Exit from the Save & Exit menu and press <Enter>. Select Yes to save changes and exit.

#### Discard Changes and Exit

Select this option to quit Setup without making any permanent changes to the system configuration and return to Main Menu. Select Discard Changes and Exit from the Save & Exit menu and press <Enter>. Select Yes to discard changes and exit.

#### Save Changes and Reset

When you have completed the system configuration changes, select this option to leave Setup and reboot the computer so the new system configuration parameters can take effect. Select Save Changes and Reset from the Save & Exit menu and press <Enter>. Select Yes to save changes and reset.

#### Discard Changes and Reset

Select this option to quit Setup without making any permanent changes to the system configuration and reboot the computer. Select Discard Changes and Reset from the Save & Exit menu and press <Enter>. Select Yes to discard changes and reset.

**Save Changes**

When you have completed the system configuration changes, select this option to save changes. Select Save Changes from the Save & Exit menu and press <Enter>. Select Yes to save changes.

**Discard Changes**

Select this option to quit Setup without making any permanent changes to the system configuration. Select Discard Changes from the Save & Exit menu and press <Enter>. Select Yes to discard changes.

**Restore Defaults**

It automatically sets all Setup options to a complete set of default settings when you select this option. Select Restore Defaults from the Save & Exit menu and press <Enter>.

**Save as User Defaults**

Select this option to save system configuration changes done so far as User Defaults. Select Save as User Defaults from the Save & Exit menu and press <Enter>.

**Restore User Defaults**

It automatically sets all Setup options to a complete set of User Defaults when you select this option. Select Restore User Defaults from the Save & Exit menu and press <Enter>.

**Boot Override**

Select a drive to immediately boot that device regardless of the current boot order.

# Appendix A

## Watchdog Timer

### About Watchdog Timer

Software stability is a major issue in most applications. Some embedded systems are not watched by humans for 24 hours. It is usually too slow to wait for someone to reboot when computer hangs. The systems need to be able to reset automatically when things go wrong. The watchdog timer gives us that solution.

The watchdog timer is a counter that triggers a system reset when it counts down to zero from a preset value. The software starts the counter with an initial value and must reset it periodically. If the counter ever reaches zero which means the software has crashed, the system will reboot.

### How to Use Watchdog Timer

#### Start

↓

#### 1. Enable configuration:

-O 2E 87  
-O 2E 87

↓

#### 2. Select logic device:

-O 2E 07  
-O 2F 07

↓

#### 3. Enable WDT:

-O 2E 30  
-O 2F 01

↓

#### 4. Activate WDT:

-O 2E F0  
-O 2F 80

↓

#### 5. Set base timer:

-O 2E F6  
-O 2F 0A ; Set reset time. Ex: A->reset time=10sec

↓

#### 6. Set timer unit (second or minute):

-O 2E F5  
-O 2F 71 ; Set timer unit.  
; Ex: 1->timer unit=second, 9->timer unit=minute

- Timeout Value Range
  - 1 to 255
  - Minute / Second

 **Note:**

If **N=00h**, the time base is set to second.

**M** = time value

00h: Time-out Disable

01h: Time-out occurs after 1 second

02h: Time-out occurs after 2 seconds

03h: Time-out occurs after 3 seconds

.

FFh: Time-out occurs after 255 seconds

If **N=08h**, the time base is set to minute.

**M** = time value

00h: Time-out Disable

01h: Time-out occurs after 1 minute

02h: Time-out occurs after 2 minutes

03h: Time-out occurs after 3 minutes

.

FFh: Time-out occurs after 255 minutes

# Appendix B

## TPM Module Installation

The TPM 2.0 (Trusted Platform Module 2.0) module is a modularized design applying to the iHPC300 and provides enhanced hardware security for the computer. In this appendix you will learn how to install the TPM 2.0 module into the iHPC300. Please read and follow the instructions below carefully.

1. Insert TPM module into the SPI interface of the motherboard, as illustrated below.

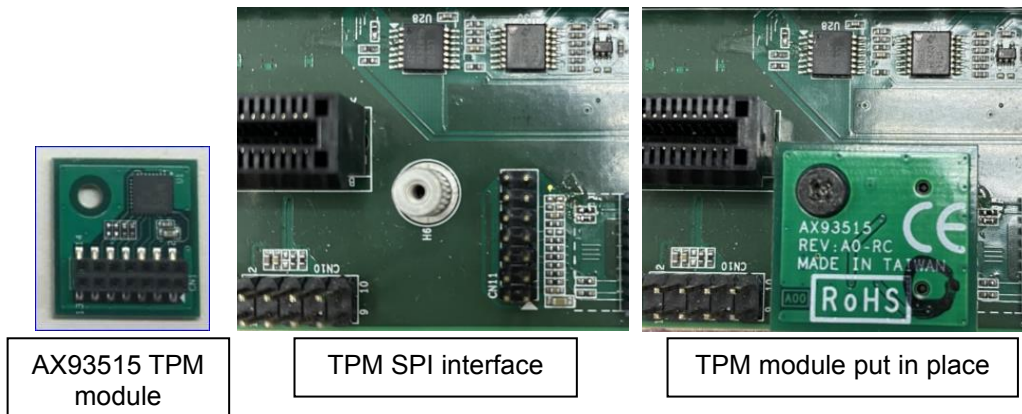

2. There are two ways to confirm whether the TPM Module is installed successfully or not:
  - a. Enter the BIOS setup menu and go to Advanced > Trusted Computing. The first line will show "TPM2.0 Device Found".

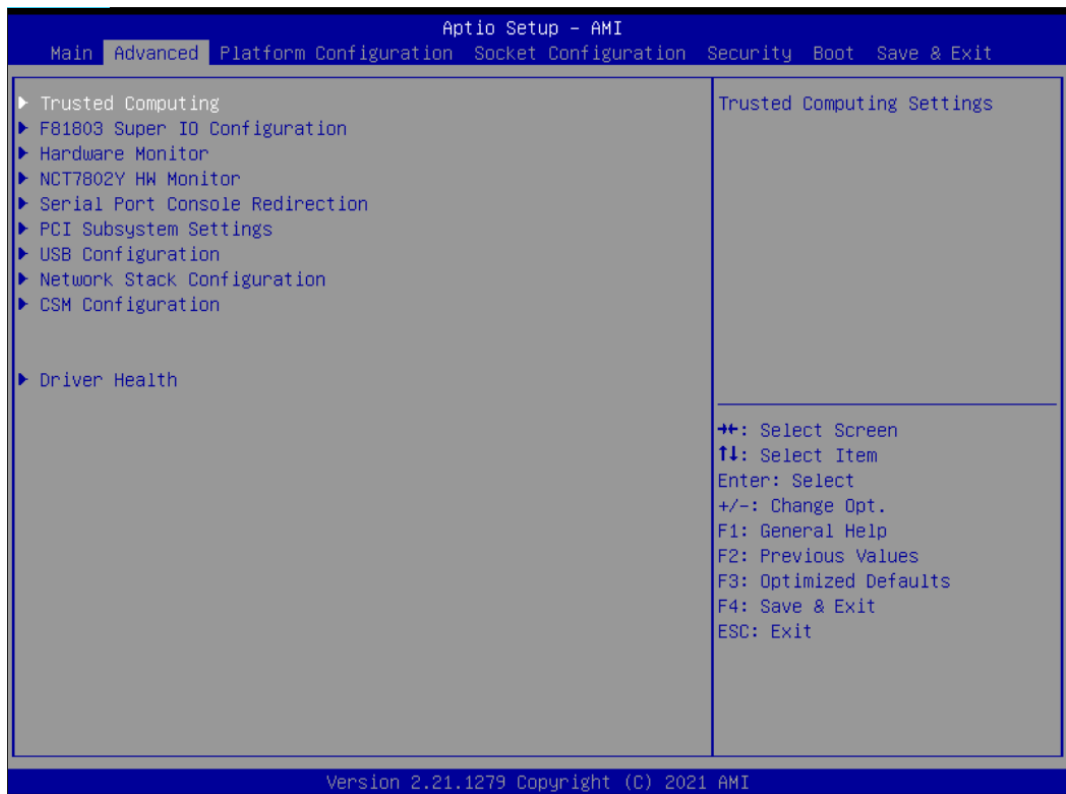

(In the Advanced menu, go to Trusted Computing)



(In the Trusted Computing section, the first line will show “TPM2.0 Device Found”, if installation is successful.)

- b. In the Windows 10 OS environment, enter Device Manager, and select the item of Security devices. The screen will show “Trusted Platform Module 2.0” if installation is successful.

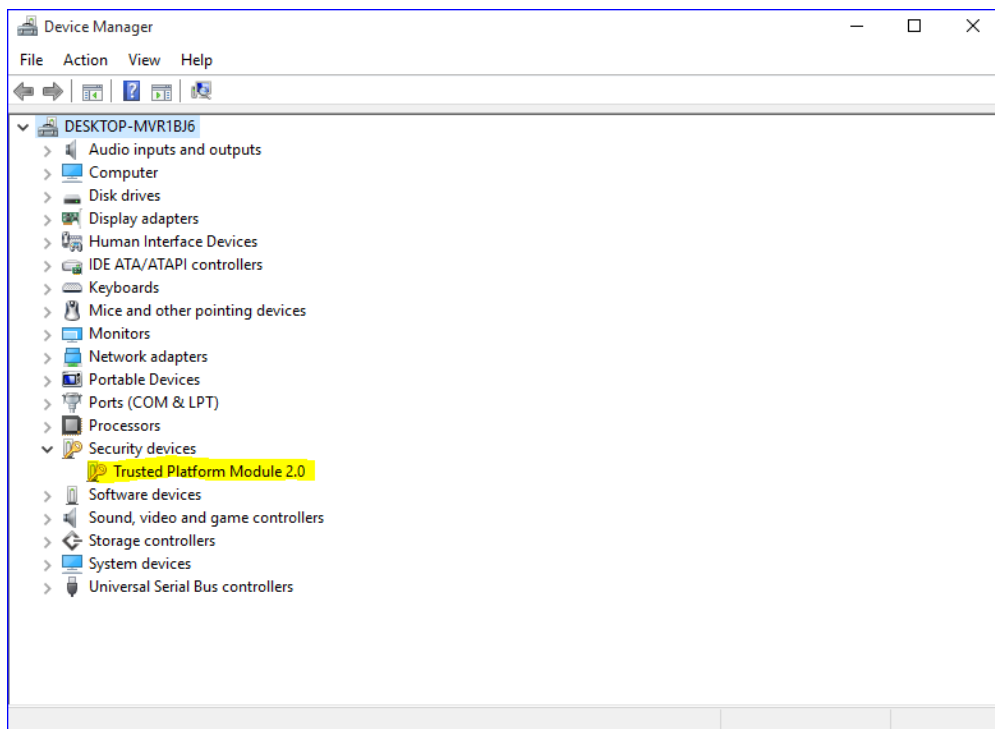

- c. In the Windows 10 OS environment, enter Control Panel, select the item of BitLocker Drive Encryption, and enter TPM Administration. The screen will show the information below if installation is successful.

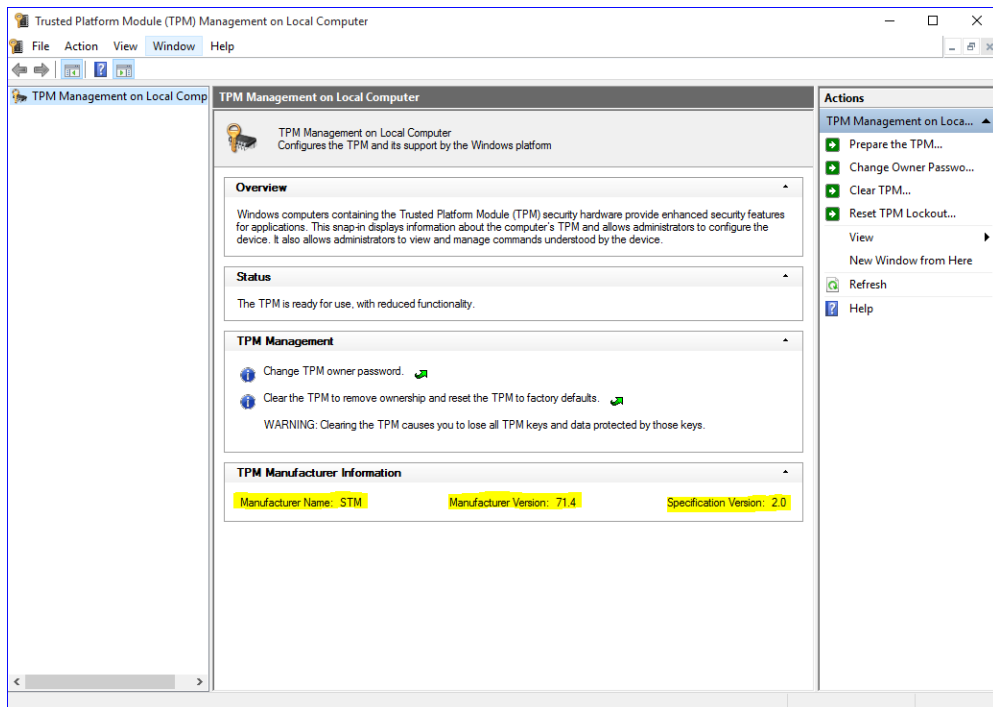

**This page is intentionally left blank.**



# Appendix C

## Configuring SATA for RAID

### Configuring SATA Hard Drive(s) for RAID Function

Before you begin the SATA configuration, please prepare:

- Two SATA hard drives (to ensure optimal performance, it is recommended that you use two hard drives with identical model and capacity). If you do not want to create RAID with the SATA controller, you may prepare only one hard drive.

**Please follow up the steps below to configure SATA hard drive(s):**

1. Install SATA hard drive(s) in your system.
2. Enter the BIOS Setup to configure SATA controller mode and boot sequence.
3. Configure RAID using the RAID BIOS utility.

#### **1. Installing SATA hard drive(s) in your system.**

Connect one end of the SATA signal cable to the rear of the SATA hard drive, and the other end to any of the available SATA port(s) on the board. Then, connect the power connector of the power supply to the hard drive.

#### **2. Configuring SATA controller mode and boot sequence by the BIOS Setup.**

You have to make sure whether the SATA controller is configured correctly by system BIOS Setup and set up BIOS boot sequence for the SATA hard drive(s).

- 2.1. Turn on your system, and then press the <Del> button to enter BIOS Setup during running POST (Power-On Self Test). If you want to create RAID, just go to the Platform Configuration/PCH SATA Configuration, select the “Configuration SATA as”, and press <Enter> for more options.

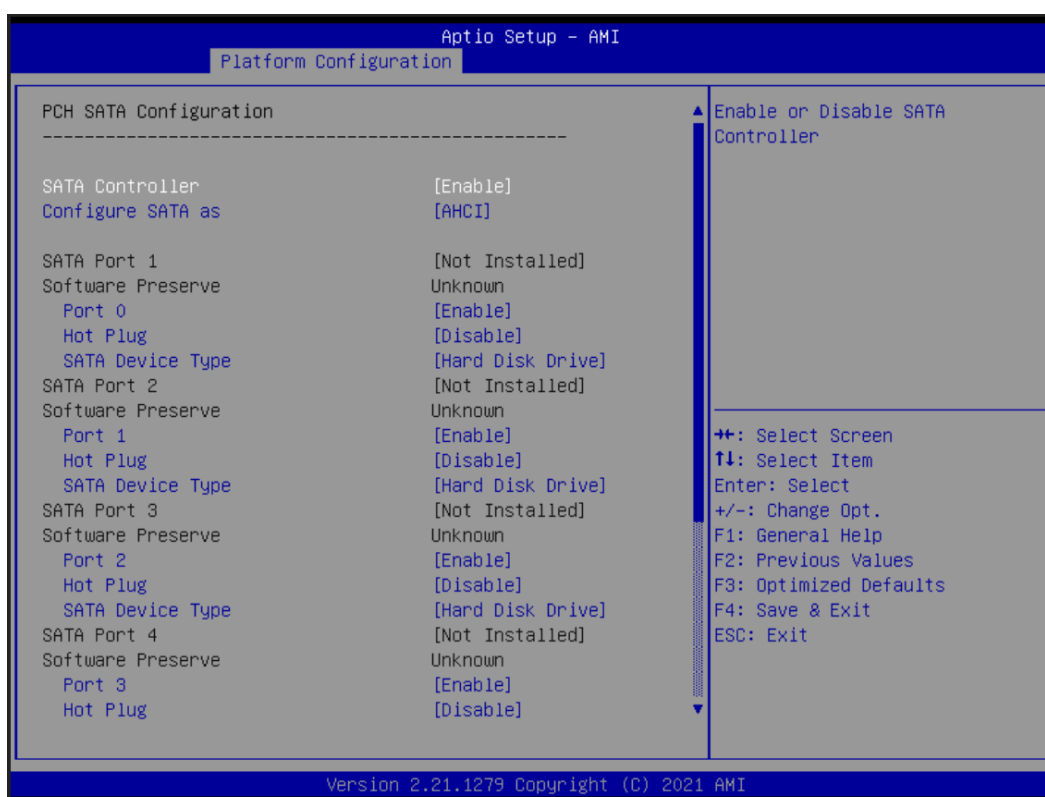

A list of options appears, please select “RAID”.

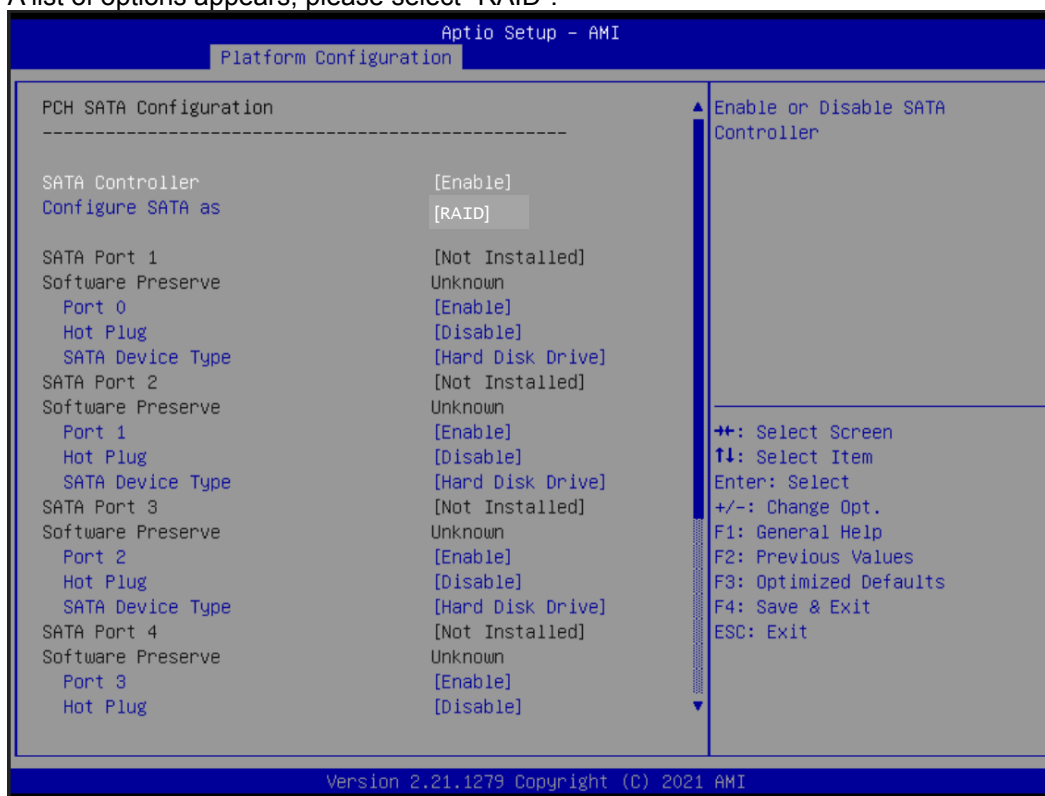

## 2.2. Enable the Load EFI Driver for RAID.

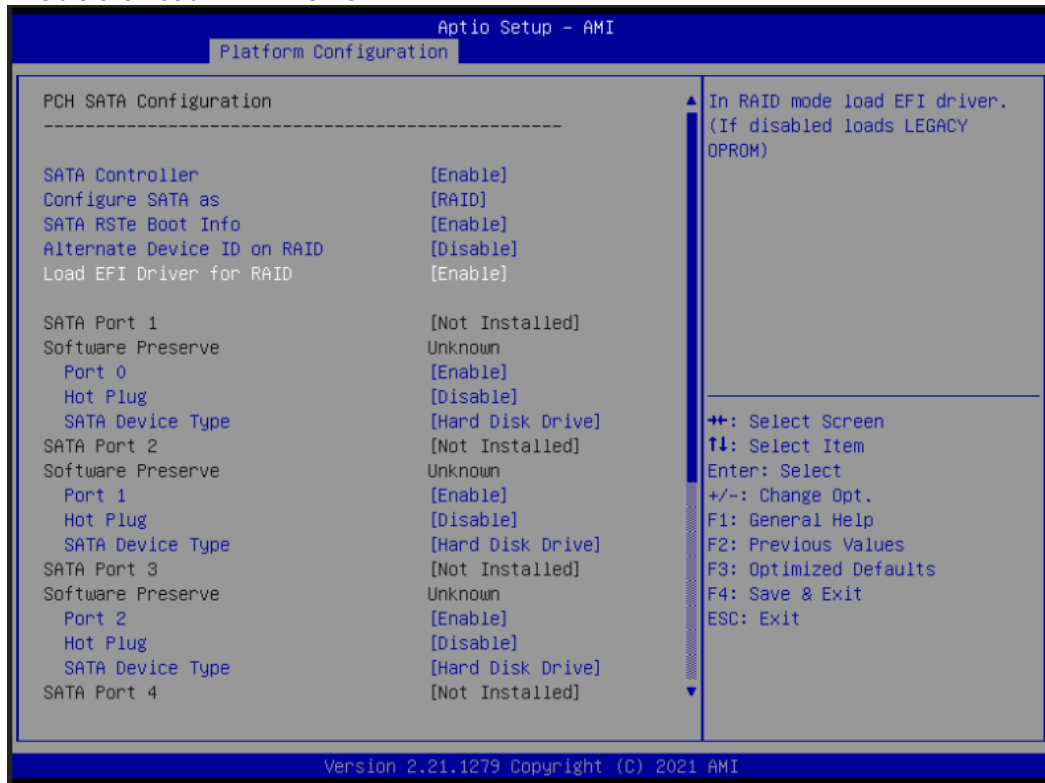

## 2.3. Under the Boot Settings menu, set DVD-ROM as the first boot option (Boot Option #1) to boot DVD-ROM after system restarts.

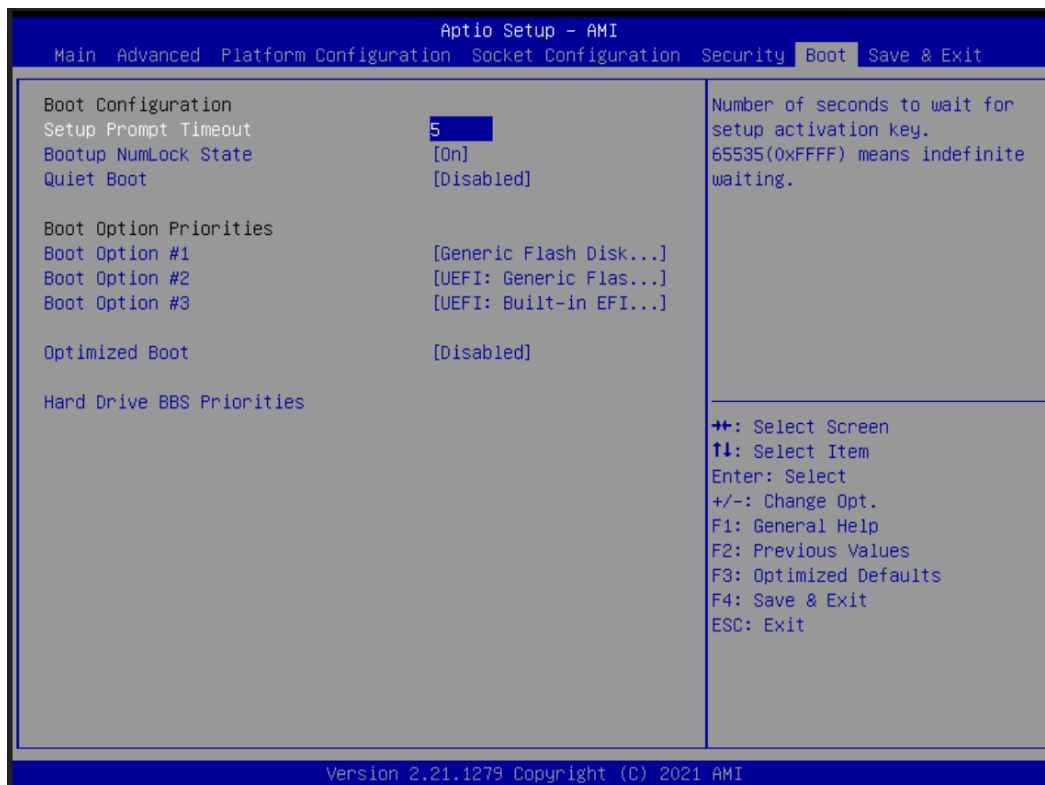

2.4. Go to the Advanced screen, select the “Intel(R) VROC SATA Controller”; next, select “Cerate RAID Volume” and press <Enter> for more options.

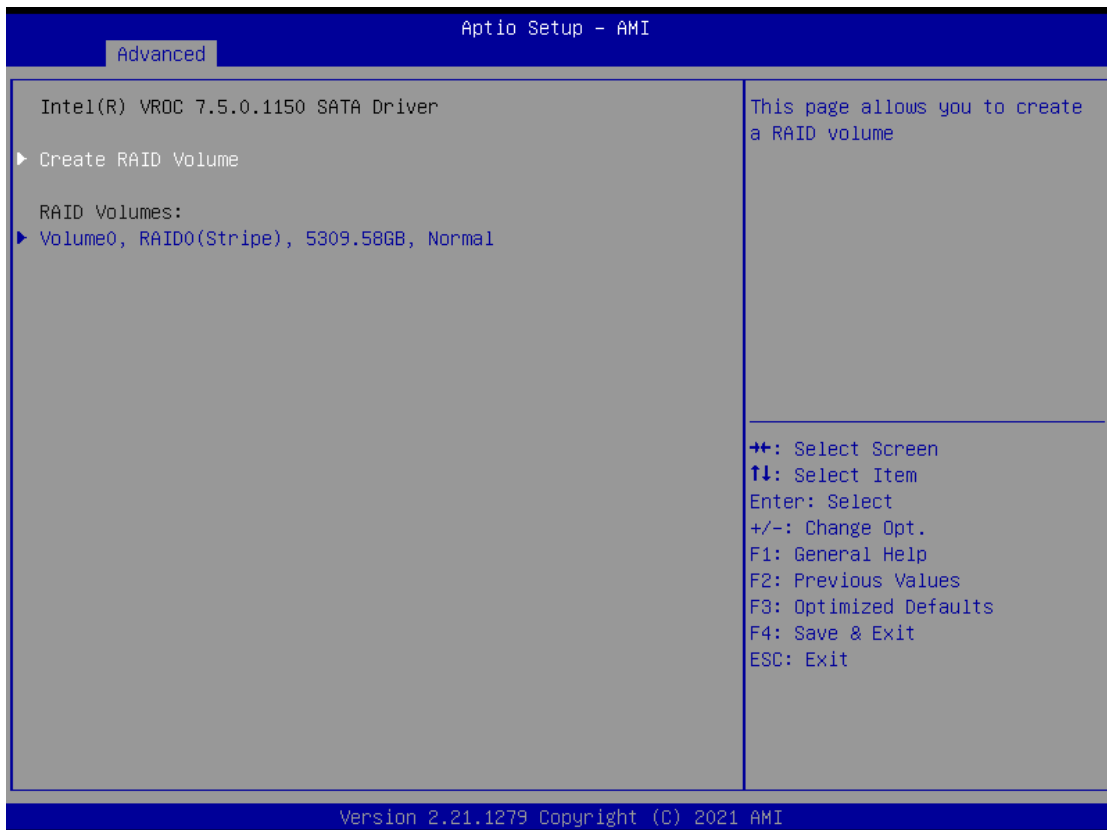
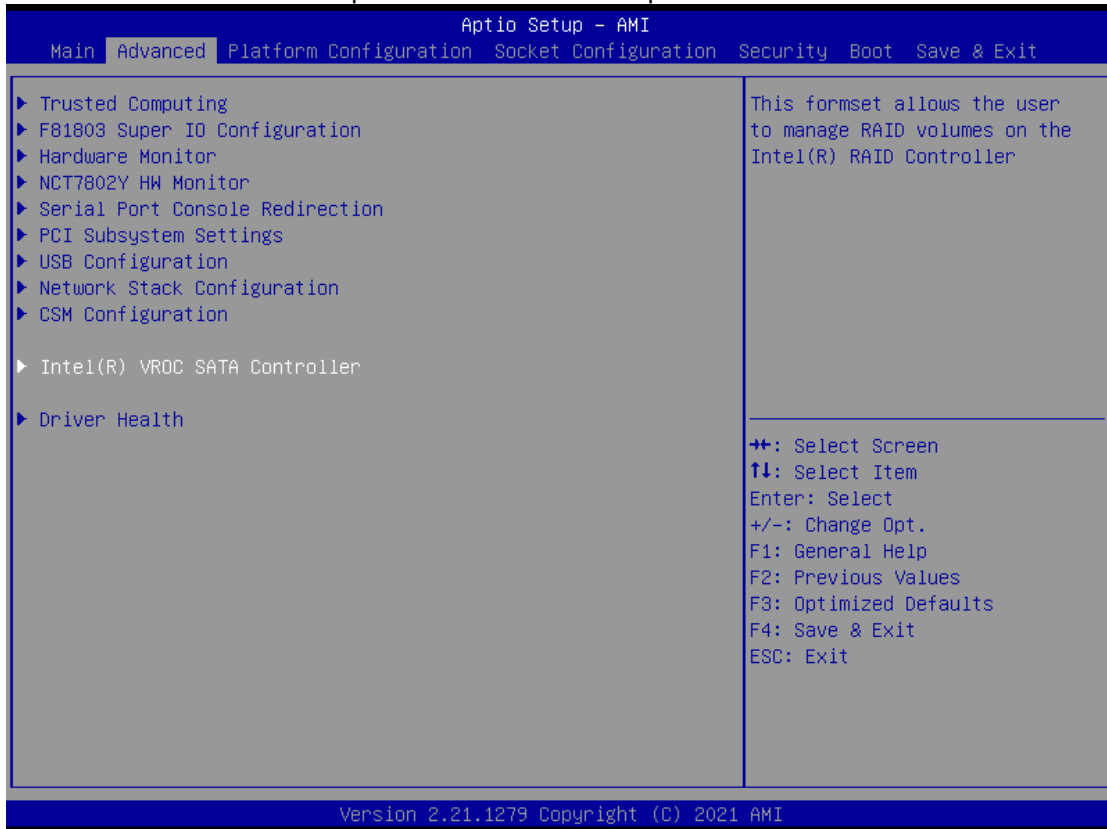

2.5. Select the “RAID Level”, and choose RAID0, 1 or 5 according to your needs.

Advanced		Aptio Setup - AMI
Create RAID Volume Name: Volume1 RAID Level: [RAID0(Stripe)] Select Disks: Port 3, TOSHIBA DT01ACA300 SN:X4RS [ ] Port 5, TOSHIBA DT01ACA300 SN:X4RS [ ] Strip Size: [128KB] Capacity (GB): 0.0		Enter a unique volume name that does not contain space at the beginning or backslash and is 16 characters or less.
▶ Create Volume Select at least two disks		++: Select Screen ↑↓: Select Item Enter: Select +/-: Change Opt. F1: General Help F2: Previous Values F3: Optimized Defaults F4: Save & Exit ESC: Exit
Version 2.21.1279 Copyright (C) 2021 AMI		

2.6. Save and exit the BIOS Setup.

**This page is intentionally left blank.**

# Appendix D

## Digital I/O

### Digital I/O Software Programming

- I2C to GPIO PCA9554PW GPIO[3:0] is Output, GPIO[7:4] is Input.
- I2C address: 0b0100100x.
- IOBASE: 0xF040
- Registers:

#### Command byte

Command	Protocol	Function
0	Read byte	Input port register
1	Read/write byte	Output port register
2	Read/write byte	Polarity inversion register
3	Read/write byte	Configuration register

The command byte is the first byte to follow the address byte during a write transmission. It is used as a pointer to determine which of the following registers will be written or read.

#### Register 0: Input port register.

This register is a read-only port. It reflects the incoming logic levels of the pins, regardless of whether the pin is defined as an input or an output by Register 3. Writes to this register have no effect.

The default 'X' is determined by the externally applied logic level, normally '1' when no external signal is externally applied because of the internal pull-up resistors.

Bit	Symbol	Access	Value	Description
7	I7	Read only	X	Determined by externally applied logic level.
6	I6	Read only	X	
5	I5	Read only	X	
4	I4	Read only	X	
3	I3	Read only	X	
2	I2	Read only	X	
1	I1	Read only	X	
0	I0	Read only	X	

**Register 1: Output port register.**

This register reflects the outgoing logic levels of the pins defined as outputs by Register 3. Bit values in this register have no effect on pins defined as inputs. Reads from this register return the value that is in the flip-flop controlling the output selection, not the actual pin value.

Bit	Symbol	Access	Value	Description
7	O7	R	1*	Reflects outgoing logic levels of pins defined as outputs by Register 3.
6	O6	R	1*	
5	O5	R	1*	
4	O4	R	1*	
3	O3	R	1*	
2	O2	R	1*	
1	O1	R	1*	
0	O0	R	1*	

\* : Default value

**Register 2: Configuration register.**

This register configures the directions of the I/O pins. If a bit in this register is set, the corresponding port pin is enabled as an input with high-impedance output driver. If a bit in this register is cleared, the corresponding port pin is enabled as an output. At reset, the I/Os are configured as inputs with a weak pull-up to VDD.

Bit	Symbol	Access	Value	Description
7	C7	R/W	1*	Configure the directions of the I/O pins. 0 = Corresponding port pin enabled as an output. 1 = Corresponding port pin configured as input (default value).
6	C6	R/W	1*	
5	C5	R/W	1*	
4	C4	R/W	1*	
3	C3	R/W	1*	
2	C2	R/W	1*	
1	C1	R/W	1*	
0	C0	R/W	1*	

\* : Default value