



AXIOMTEK

ICO300 Series

**Robust Din-rail Fanless Embedded
System**

User's Manual



Disclaimers

This manual has been carefully checked and believed to contain accurate information. Axiomtek Co., Ltd. assumes no responsibility for any infringements of patents or any third party's rights, and any liability arising from such use.

Axiomtek does not warrant or assume any legal liability or responsibility for the accuracy, completeness or usefulness of any information in this document. Axiomtek does not make any commitment to update the information in this manual.

Axiomtek reserves the right to change or revise this document and/or product at any time without notice.

No part of this document may be reproduced, stored in a retrieval system, or transmitted, in any form or by any means, electronic, mechanical, photocopying, recording, or otherwise, without the prior written permission of Axiomtek Co., Ltd.

©Copyright 2022 Axiomtek Co., Ltd.

All Rights Reserved

March 2022, Version A7

Printed in Taiwan

Safety Precautions

Before getting started, please read the following important safety precautions.

1. The ICO300 does not come equipped with an operating system. An operating system must be loaded first before installing any software into the computer.
2. Be sure to ground yourself to prevent static charge when installing the internal components. Use a grounding wrist strap and place all electronic components in any static-shielded devices. Most electronic components are sensitive to static electrical charge.
3. Disconnect the power cord from the ICO300 before making any installation. Be sure both the system and the external devices are turned OFF. Sudden surge of power could ruin sensitive components. Make sure the ICO300 is properly grounded.
4. Make sure the voltage of the power source is correct before connecting the equipment to the power outlet.
5. Turn OFF the system power before cleaning. Clean the system using a cloth only. Do not spray any liquid cleaner directly onto the screen.
6. Do not leave this equipment in an uncontrolled environment where the storage temperature is below -45°C or above 85°C . It may damage the equipment.
7. Do not open the system's back cover. If opening the cover for maintenance is a must, only a trained technician is allowed to do so. Integrated circuits on computer boards are sensitive to static electricity. To avoid damaging chips from electrostatic discharge, observe the following precautions:
 - Before handling a board or integrated circuit, touch an unpainted portion of the system unit chassis for a few seconds. This will help to discharge any static electricity on your body.
 - When handling boards and components, wear a wrist-grounding strap, available from most electronic component stores.
8. Caution
Risk of explosion if battery is replaced by an incorrect type dispose of used batteries according to the instructions.
9. Warning
Hot Surface Do NoT Touch.
Restricted access area: The equipment should only be installed in a Restricted Access Area.
10. This product is intended to be supplied by IEC/UL Listed Power Adapter or DC power source, output meets SELV, rated 12-24Vdc, minimum 1.42-0.74A, Tma = 70 degree C, and the altitude of operation = 5000m.
If need further assistance with purchasing the power source, please contact to manufacturer for further information.
11. Ensure to connect the power cord of power adapter to a socket-outlet with earthing connection.

Classification

1. Degree of protection against electric shock: not classified
2. Degree of protection against the ingress of water: IP40
3. Equipment not suitable for use in the presence of a flammable anesthetic mixture with air or with oxygen or nitrous oxide.
4. Mode of operation: Continuous
5. Type of protection against electric shock: Class I equipment

General Cleaning Tips

You may need the following precautions before you begin to clean the computer. When you clean any single part or component for the computer, please read and understand the details below fully.

When you need to clean the device, please rub it with a piece of dry cloth.

1. Be cautious of the tiny removable components when you use a vacuum cleaner to absorb the dirt on the floor.
2. Turn the system off before you start to clean up the component or computer.
3. Never drop the components inside the computer or get circuit board damp or wet.
4. Be cautious of all kinds of cleaning solvents or chemicals when you use it for the sake of cleaning. Some individuals may be allergic to the ingredients.
5. Try not to put any food, drink or cigarette around the computer.

Cleaning Tools

Although many companies have created products to help improve the process of cleaning your computer and peripherals users can also use household items to clean their computers and peripherals. Below is a listing of items you may need or want to use while cleaning your computer or computer peripherals.

Keep in mind that some components in your computer may only be able to be cleaned using a product designed for cleaning that component, if this is the case it will be mentioned in the cleaning.

- Cloth: A piece of cloth is the best tool to use when rubbing up a component. Although paper towels or tissues can be used on most hardware as well, we still recommend you to rub it with a piece of cloth.
- Water or rubbing alcohol: You may moisten a piece of cloth a bit with some water or rubbing alcohol and rub it on the computer. Unknown solvents may be harmful to the plastics parts.
- Vacuum cleaner: Absorb the dust, dirt, hair, cigarette particles, and other particles out of a computer can be one of the best methods of cleaning a computer. Over time these items can restrict the airflow in a computer and cause circuitry to corrode.
- Cotton swabs: Cotton swabs moistened with rubbing alcohol or water are excellent tools for wiping hard to reach areas in your keyboard, mouse, and other locations.
- Foam swabs: Whenever possible it is better to use lint free swabs such as foam swabs.



Note: *We strongly recommended that you should shut down the system before you start to clean any single components.*

Please follow the steps below:

1. Close all application programs
2. Close operating software
3. Turn off power
4. Remove all device
5. Pull out power cable

Scrap Computer Recycling

If the computer equipments need the maintenance or are beyond repair, we strongly recommended that you should inform your Axiomtek distributor as soon as possible for the suitable solution. For the computers that are no longer useful or no longer working well, please contact your Axiomtek distributor for recycling and we will make the proper arrangement.

Trademarks Acknowledgments

Axiomtek is a trademark of Axiomtek Co., Ltd. IBM, PC/AT, PS/2, VGA are trademarks of International Business Machines Corporation.

Intel[®] and Pentium[®] are registered trademarks of Intel Corporation.

MS-DOS, Microsoft C and QuickBASIC are trademarks of Microsoft Corporation.

VIA is a trademark of VIA Technologies, Inc.

SST is a trademark of Silicon Storage Technology, Inc.

UMC is a trademark of United Microelectronics Corporation. Other brand names and trademarks are the properties and registered brands of their respective owners.

Table of Contents

Safety Precautions	iii
Classification	iv
General Cleaning Tips	iv
Scrap Computer Recycling	vi
CHAPTER 1 INTRODUCTION	1
1.1 General Description	1
1.2 System Specifications	3
1.2.1 CPU	3
1.2.2 BIOS	3
1.2.3 System Memory	3
1.2.4 Display	3
1.2.5 Ethernet Ports	3
1.2.6 Storages	3
1.2.7 Wireless	3
1.2.8 USB	4
1.2.9 COM	4
1.2.10 Power	4
1.2.11 Power Button (ICO300-PB)	5
1.2.12 DIO (ICO300-DIO)	5
1.2.13 WatchDog Timer (WDT)	5
1.2.14 Restore BIOS Optimal Defaults (JP2)	5
1.2.15 System LED	6
1.2.16 Operation Temperature	6
1.2.17 Storage Temperature	6
1.2.18 Humidity	6
1.2.19 Weight	6
1.2.20 Dimensions	6
1.2.21 System I/O Outlets	6
1.3 Dimensions	7
1.4 I/O Outlets	9
CHAPTER 2 HARDWARE INSTALLATION	13
2.1 Installing the Memory Module	13
2.2 Installing the CompactFlash (CF)	15
2.3 Installing the Hard Disk Drive	17
2.4 Installing Din-rail Mounting	19
2.5 Installing Wall Mounting (optional)	20
CHAPTER 3 AMI UEFI BIOS UTILITY	22
3.1 Entering Setup	22
3.2 The Main Menu	23
3.3 Advanced Features	24
3.4 Chipset Feature	40
3.5 Security	42
3.6 Boot Type	44
3.7 Save & Exit	48

APPENDIX A WATCHDOG TIMER	52
About Watchdog Timer	52
How to Use Watchdog Timer	52
APPENDIX B POWER BUTTON SETTING FOR WINDOW SOFTWARE ...	54

CHAPTER 1

INTRODUCTION

This chapter contains general information and detailed specifications of the ICO300. The Chapter 1 includes the following sections:

- General Description
- System Specification
- Dimensions
- I/O Outlets

1.1 General Description

ICO300 Din-rail fanless embedded system is suitable for communications control and for protocol converter applications in critical environments. Built for rugged work environments, ICO300 features an extra low power consumption Intel® ATOM™ E3815 (1.46GHz) or E3827 (1.75GHz) processors supporting industrial temperature range of -20°C to +70°C. Its front accessible I/O cabling is very convenient for wiring and maintenance. ICO300 offers a VGA output, making it particularly well-suited for communication control, SCADA and industrial automation. Its compact size with Din-rail mounting allows for easy installation into control cabinet. Pre-installed with Linux, Windows® 7 embedded and Windows 8 embedded, ICO300 provides programmers with a friendly environment for developing application software at a lower cost.

ICO300 is robust industrial-grade hardware design and adopts the advanced cooling system, besides, supporting the CompactFlash™ and SATA SSD (or HDD), which makes it especially suitable for field control & monitoring system solution for following markets:

Utility Industries (Water; Energy; Chemical Plant; Mining...)

Public Transportation Industries (Traffic/ Highway Control; Train/Bus Control...)

Homeland Security (Weather Monitoring/Alarm System...)

● Checklist

- | | |
|--------------------------|----------------------------|
| ✓ ICO300 System Unit x 1 | ✓ Power terminal block x 1 |
| ✓ Screws | ✓ DVD x 1 (for Driver) |
| ✓ CF Mylar x 1 | ✓ Din-rail Kit x1 |
| ✓ Cable Tie x1 | ✓ SATA+Power HDD cable x1 |



Note: Please contact your local vendors if any damaged or missing items.

- **Features**

- Fanless design
- Wide temperature operation of -20°C - +70°C (-40°C - +70°C for optional)
- 2 10/100/1000 Base-T Ethernets with Magnetic Isolated Protection
- 4 COM Ports support RS-232/422/485
- 1 Wireless (USB and PCIe Interface)
- Support one 2.5" SATA drive bay and one CompactFlash™ (or mSATA)
- Wide range 12–24V DC-in with terminal block
- 1 DI/DO (8-bit programmable, DB9 female connector) (ICO300-DIO)
- Din-rail mounting
- Wall mounting (optional)
- Passed UL Certification, CE with FCC testing

- **Embedded O.S. Supported**

- ICO300 not only supports Windows®7 and Windows®8, but also supports embedded OS, such as Windows® 7 embedded, Windows® 8 embedded and Linux package support. For storage device, ICO300 supports one SATA SSD (or HDD) and one type II CompactFlash™ socket.

1.2 System Specifications

1.2.1 CPU

- Onboard Intel® ATOM™ E3815 (1.46 GHz) processor or E3827 (1.75GHz) processor

1.2.2 BIOS

- AMI (American Megatrends Inc.) UEFI (Unified Extensible Firmware Interface) BIOS.

1.2.3 System Memory

- One DDR3L 204-pin SO-DIMM (1.35V) slot.
- Supports 1333/1600 MHz up to 4GB (E3815), up to 8GB (E3827).

1.2.4 Display

- A slim type 15-pin D-Sub connector as VGA connector.

1.2.5 Ethernet Ports

- LAN Chip : Intel Ethernet Controller I211-AT.
- LAN Chip : Intel Ethernet Controller I210-IT.(ICO300-WT)
LAN 1 and LAN 2

The board has dual RJ-45 connectors, support 10/100/1000 Base-T with 1.5KV magnetic isolated protection.

1.2.6 Storages

- 1 x 2.5" SATA drive bay.
- 1 x CompactFlash™ Typell socket (or mSATA).

1.2.7 Wireless

- 1 x Full size Mini Card slot supports module with USB and PCIe Interface.
- 1 x SIM Card Socket.
- 2 x Antenna holes.



Note: CF and mSATA function can be either one, it can be selected by BIOS menu.
mSATA and wireless use the same slot, and only one of them can be selected.

1.2.8 USB

- 2 x USB2.0
- USB Pin Define :

Pin	Signal USB Port 0	Pin	Signal USB Port 1
1	VCC	5	VCC
2	D-	6	D-
3	D+	7	D+
4	GND	8	GND

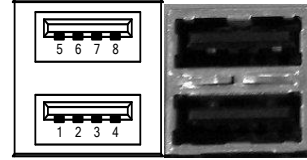

1.2.9 COM

- 4 ports DB9 support RS-232/422/485 which can be selected by BIOS.
- Supports Auto Flow Control in RS485 mode.
- Serial Port Pin Define: (DB9 Male) as below

COM1~4

Pin	RS-232	RS-422	RS-485
1	DCD	TX-	Data-
2	RXD	TX+	Data+
3	TXD	RX+	--
4	DTR	RX-	--
5	GND	GND	GND
6	DSR	--	--
7	RTS	--	--
8	CTS	--	--
9	RI	--	--

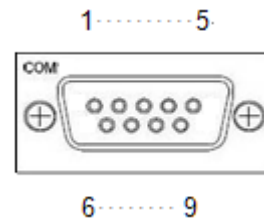

1.2.10 Power

- Wide-range 12 - 24V DC power input with terminal block.
- OVP and Reverse protection.
- Input Terminal Block (CN2) suitable for 12-28 AWG (0.0804-3.31 mm²) wire size, torque value 4.5 lb-in (0.5085 Nm). Material VW-1, Must be installed by skilled person.

Pin	Signal
1	+
2	NC
3	-

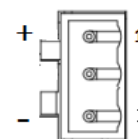

1.2.11 Power Button (ICO300-PB)



- AT auto power on
- Power button setting for software must be set up firstly.



Note: Power button setting for Window software is offered on APPENDIX B for reference.

1.2.12 DIO (ICO300-DIO)

- One DB9 female connector supports 8 bits TTL level programmable digital input/output
- The voltage of TTL is 5V
- The programming is as follow:
 - I/O sink current is 8~10mA (Output drive current \pm 50 mA)
 - Input/Output can be programmed

Pin	Signal
1	DIO0
2	DIO1
3	DIO2
4	DIO3
5	DIO4
6	DIO5
7	DIO6
8	DIO7
9	GND

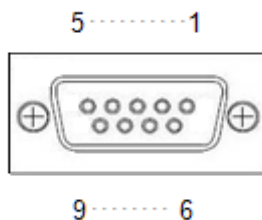

1.2.13 WatchDog Timer (WDT)

- 1~255 seconds or minutes; up to 255 levels.

1.2.14 Restore BIOS Optimal Defaults (JP2)

- Put jumper clip to pin 2-3 for a few seconds then move it back to pin 1-2. Doing this procedure can restore BIOS optimal defaults.

Function	Setting
Normal (Default)	1-2
Restore BIOS optimal defaults	2-3



1.2.15 System LED

- There are showed the LED's indicators and functional descriptions.

LED Name	Description	Color
ACT	Indicate the storage status and it's flashing when storage access.	Green
PWR	Indicate the Power status. When the DC input is acceptable, the LED will ON.	Yellow

1.2.16 Operation Temperature

- -20°C ~ +70°C
- -40°C ~ +70°C (optional for ICO300-WT)

1.2.17 Storage Temperature

- -40°C ~ +85°C

1.2.18 Humidity

- 10% ~ 95% (non-condensation)

1.2.19 Weight

- 1 kg

1.2.20 Dimensions

- 48mm(1.88") (W) x110mm(4.33") (D) x155mm(6.1") (H)

1.2.21 System I/O Outlets

- Four 9-pin D-Sub male connectors, COM1~COM4.
- One 15-pin D-Sub female connector for VGA.
- Two 10/100/1000 Base-T RJ-45 with 1.5KV magnetic isolated protection.
- Two USB 2.0 connectors.
- One DC Power Input with terminal block.
- One 9-pin D-Sub Female connectors for DIO. (ICO300-DIO)
- Two Antenna holes.

1.3 Dimensions

The following diagrams show you dimensions and outlines of the ICO300/ICO300-DIO/ICO300-PB/ICO300-DIO-PB.

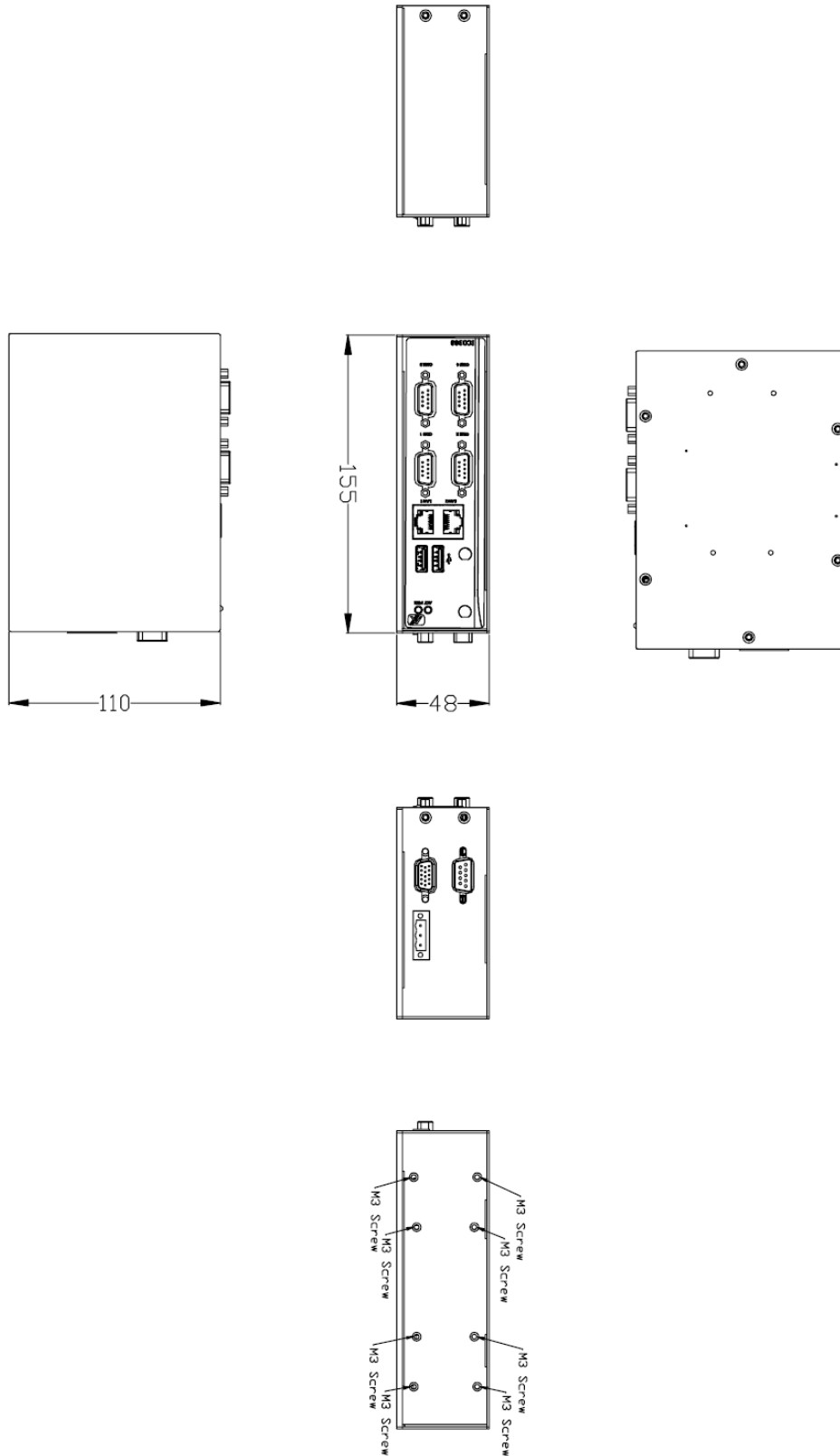

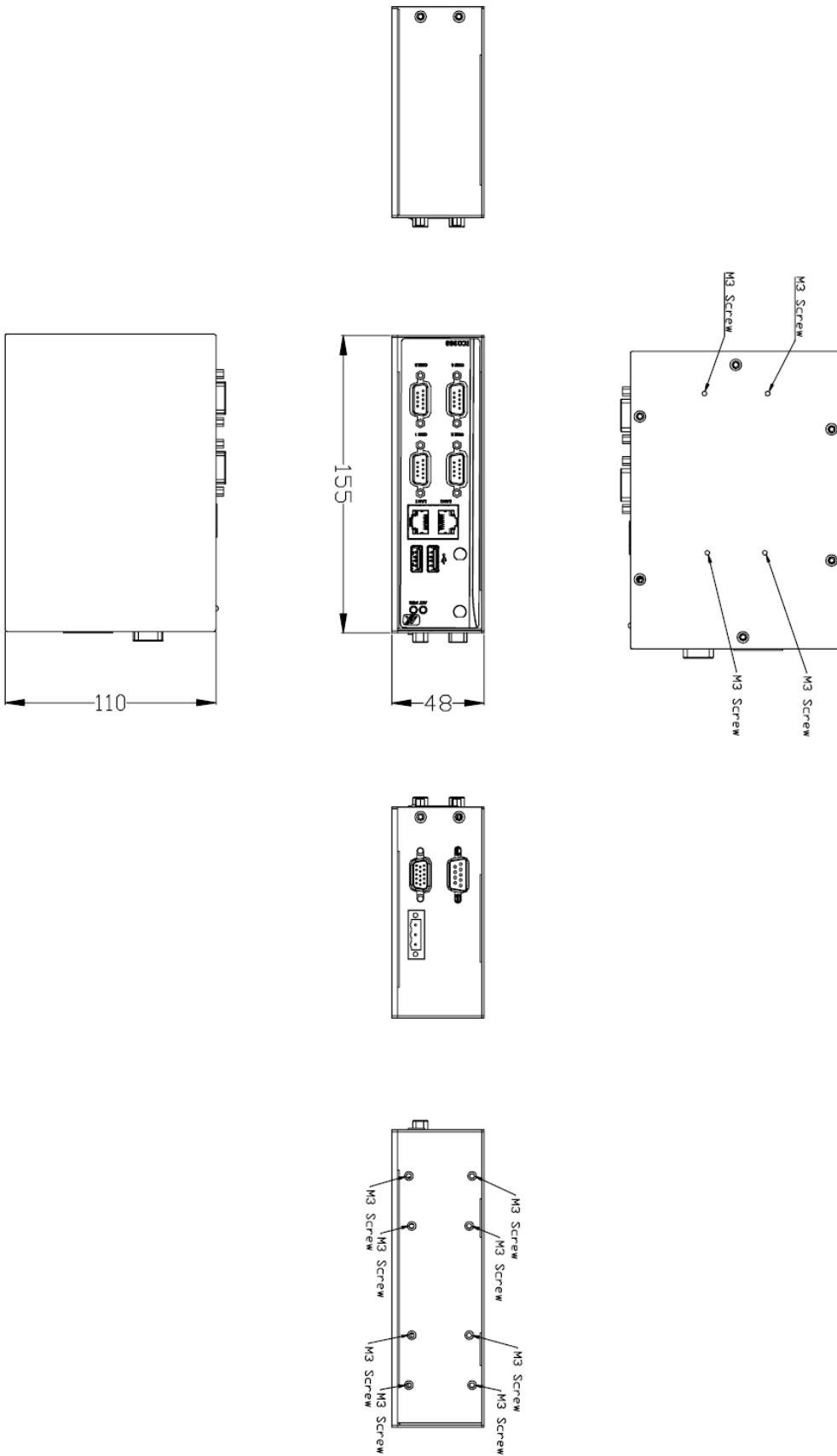

1.4 I/O Outlets

The following figures show you I/O outlets on front view and top view of the ICO300/ICO300-DIO/ICO300-PB/ICO300-DIO-PB..

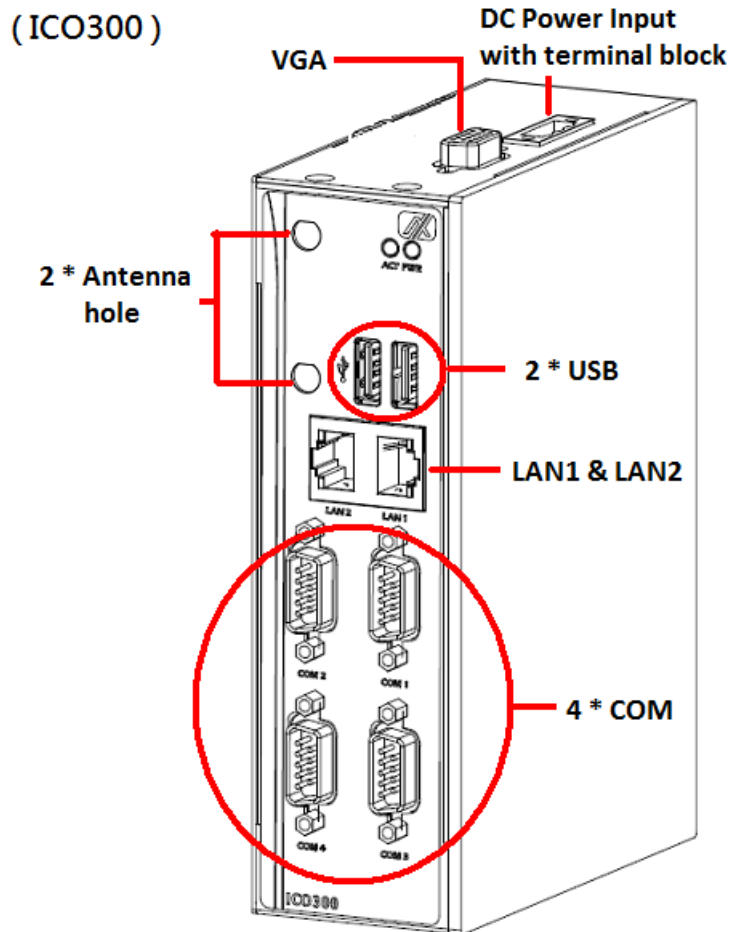

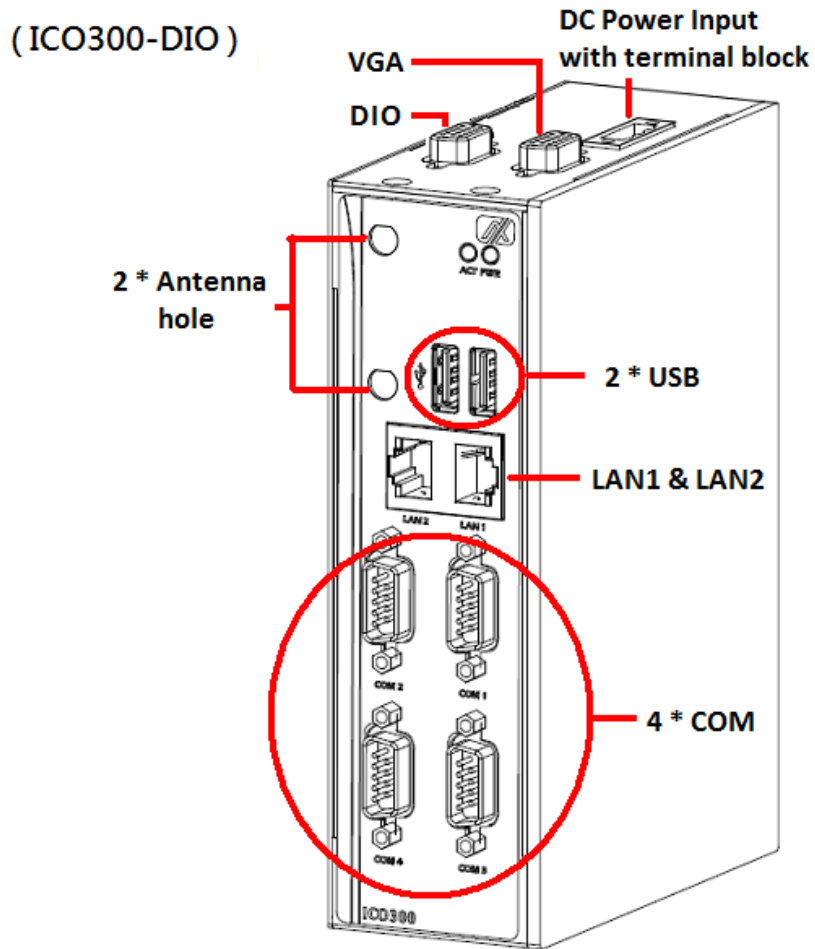

(ICO300 - PB)

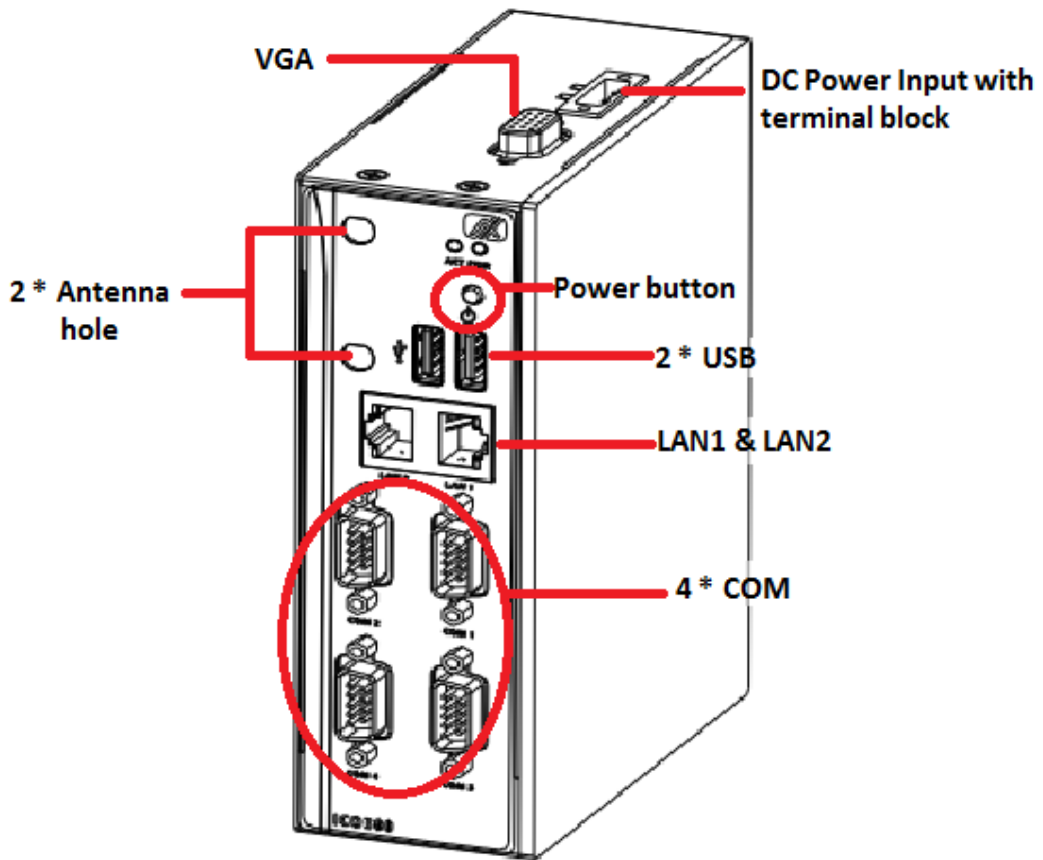

(ICO300 - DIO - PB)

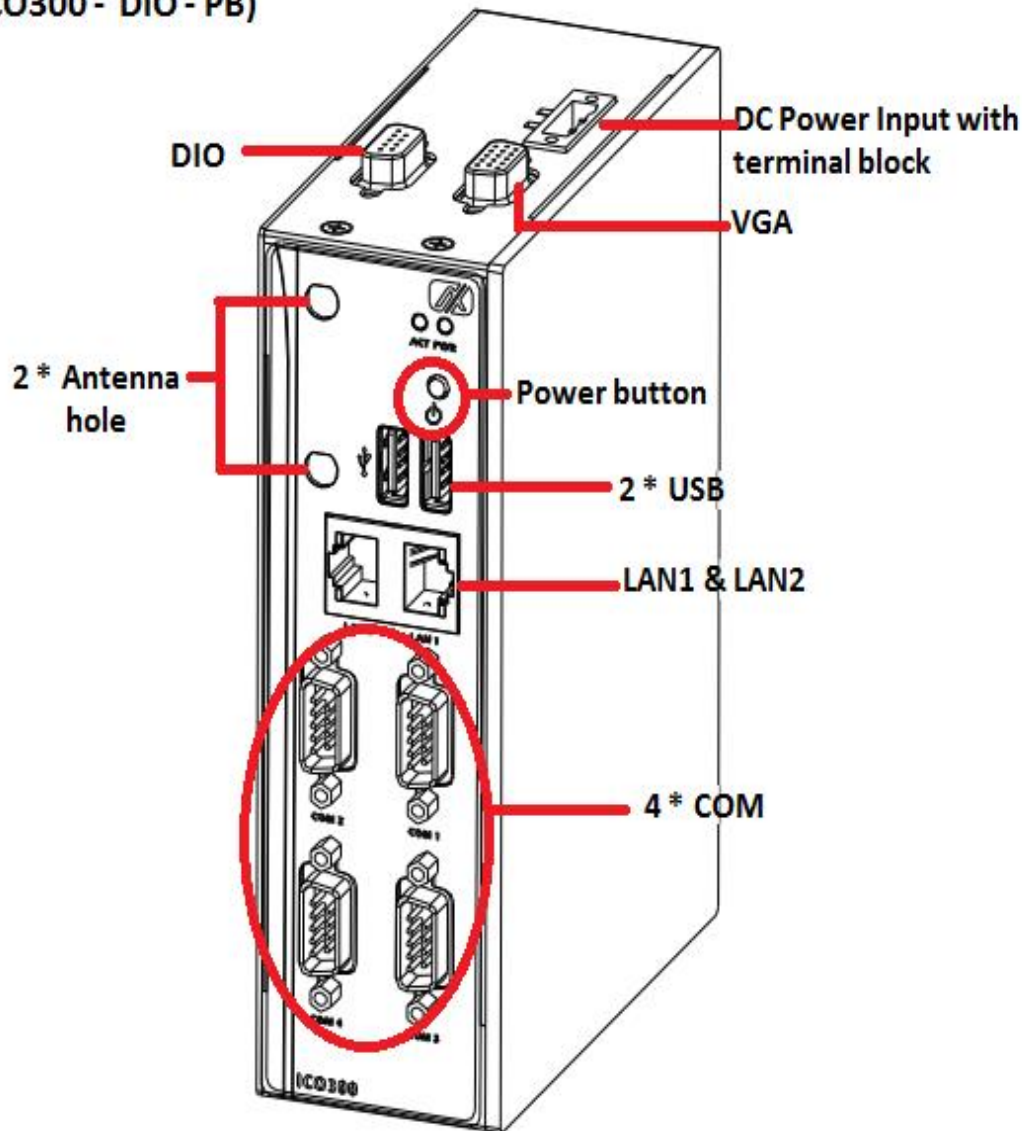

CHAPTER 2 HARDWARE INSTALLATION

The ICO300 is convenient for your various hardware configurations, such as Memory Module and Hard Disk Drive. The chapter 2 will show you how to install the hardware. It includes:

2.1 Installing the Memory Module

Step 1 Turn off the system.

Step 2 Loosen all screws of the cover and remove the cover from the system.



Step 3 Use two fingers to hold the memory module, and insert the gold figure into the slot and push the module down.

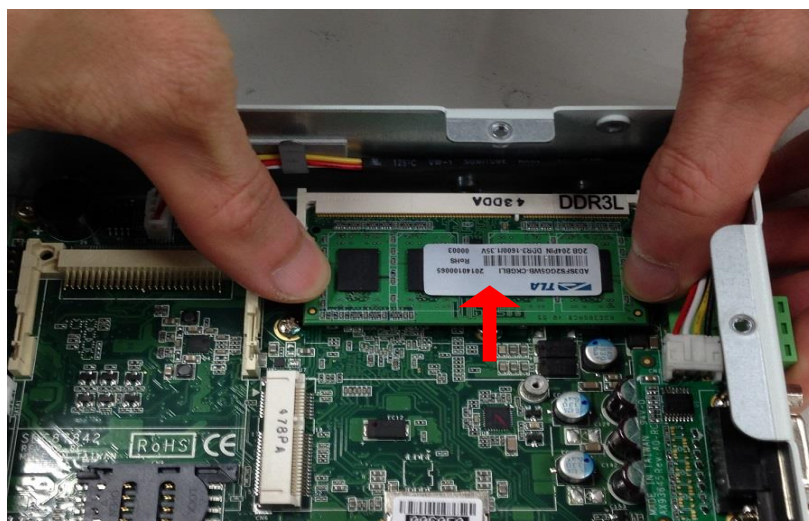

Step 4 The memory module is locked by two latches on the sides. We strongly recommend using “LDC737” silicone on the two sides of the memory for good ability of vibration.



Step 5 Put the cover back to the system, and fasten screws tight close the chassis.

2.2 Installing the CompactFlash (CF)

Step 1 Turn off the system.

Step 2 Loosen all screws of the cover and remove the cover from the system.



Step 3 Stick CF mylar on CF card.

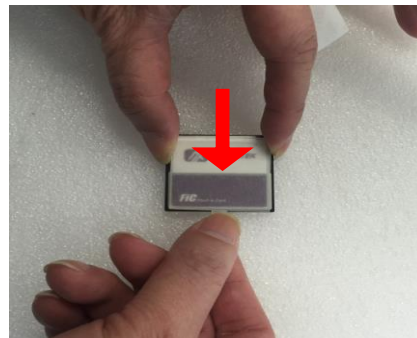

Step 4 Insert the CF card into the socket tightly and lock the CF card.

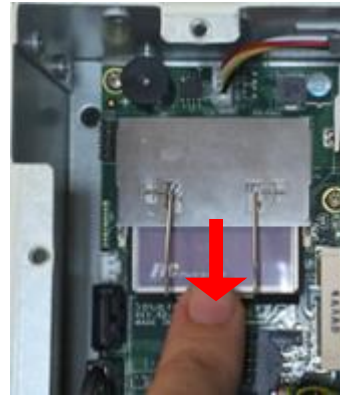
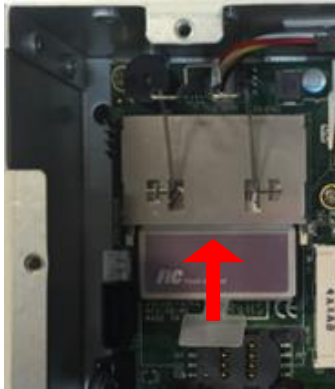

 **Note:** *Unlock the CF card from the socket and pull out the CF card when taking out CF card.*

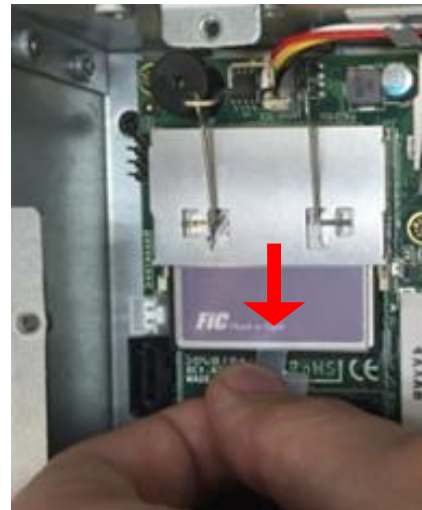

2.3 Installing the Hard Disk Drive

Step 1 Turn off the system.

Step 2 Loosen all screws of the cover and remove the cover from the system.



Step 3 Loosen 4pcs screws of the cover, and put the HDD into the HDD bracket and fix the HDD by 4pcs of screws in the accessory bag.

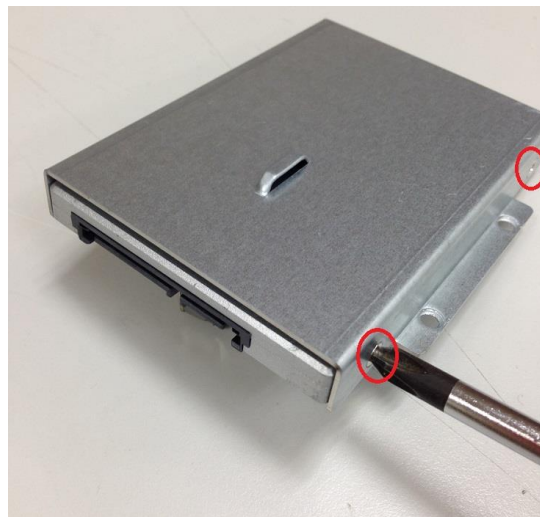
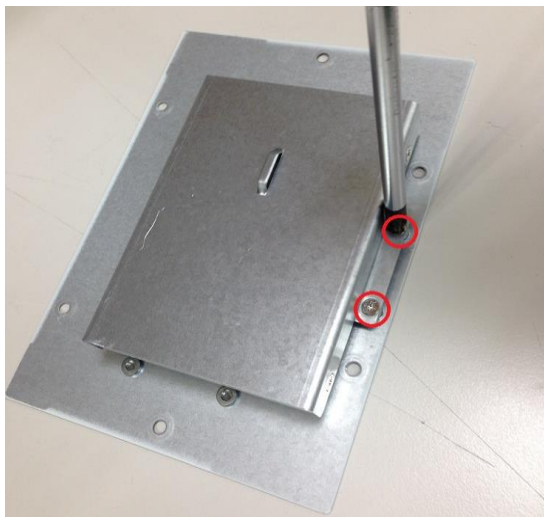

Step 4 Put the HDD bracket on the cover and use 4pcs screws to fix tightly. Takes the

HDD SATA+Power HDD cable and Cable Tie out from the accessory bag and connect SATA+Power HDD cable to HDD then use Cable Tie to fix it on the HDD bracket, cut off the lengthy Cable Tie.



Step 5 Connect SATA+Power HDD cable to the board connector, SATA side first then power side second.

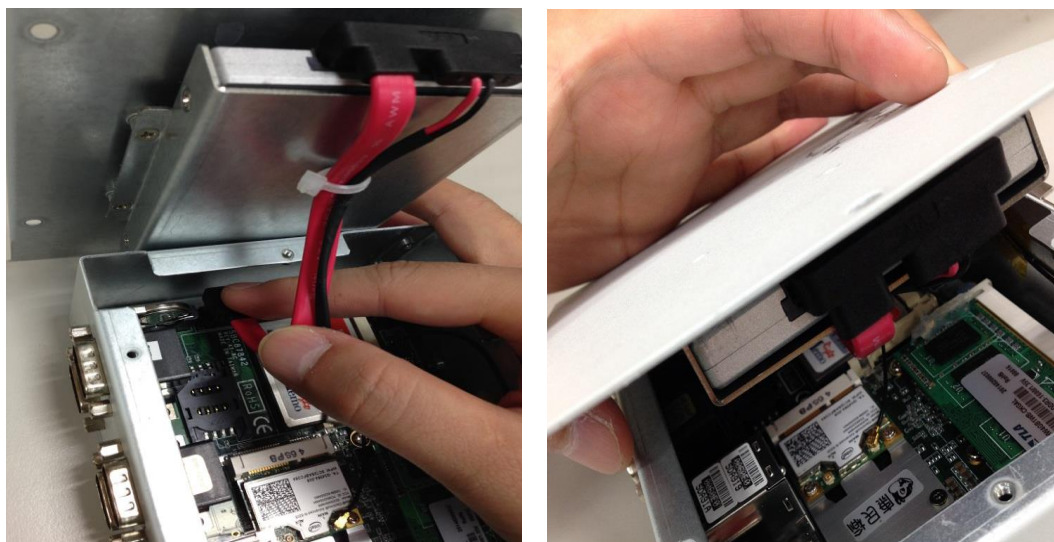

Step 6 Put the cover back to the system, and fasten screws tight close the chassis.

2.4 Installing Din-rail Mounting

The ICO300 provides Din-rail Mount for customers can install as below:

Step 1 Prepare Din-rail Mount assembling components (screws and bracket) ready.



 **Note:** ***Only** 4mm length M3 type screws can be accepted.*

Step 2 Assembly the bracket to the system and fasten screws tight.

Method 1:

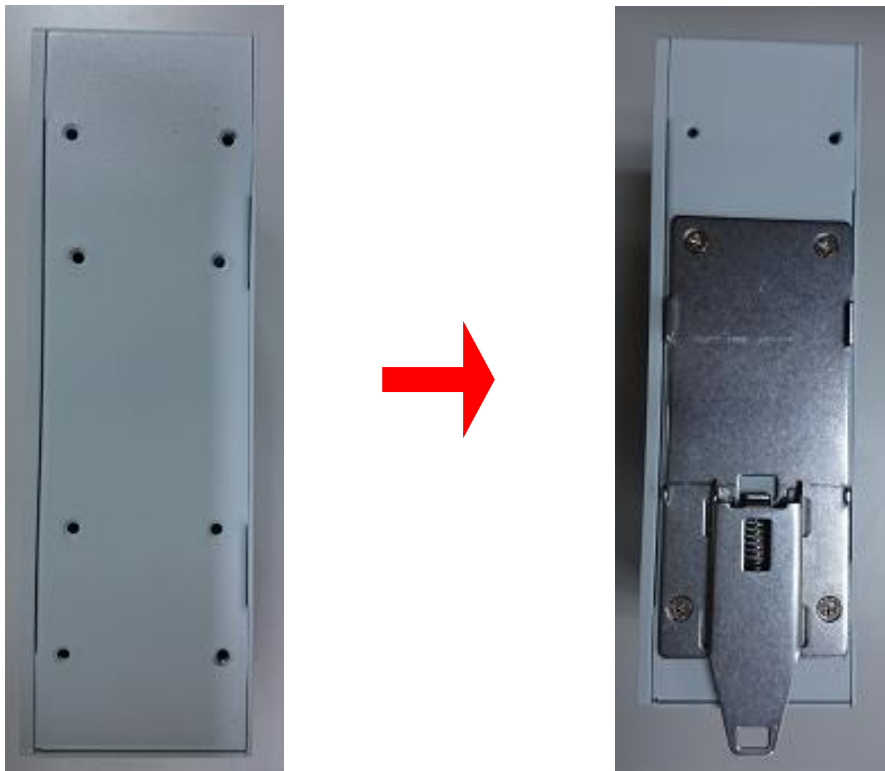

2.5 Installing Wall Mounting (optional)

The ICO300 provides Wall Mounting for customers can install as below:

Step 1 Prepare Wall Mount assembling components (screws and bracket) ready.

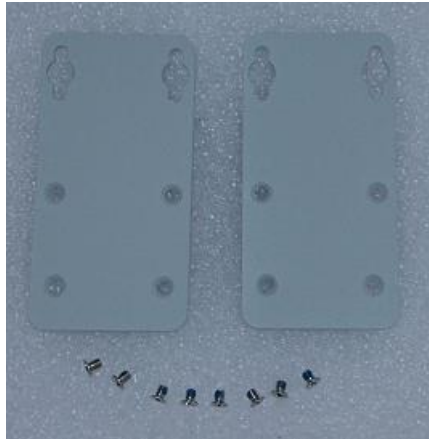

Step 2 Assembly the bracket to the system, and fasten screws tight.



This page is intentionally left blank.

CHAPTER 3 AMI UEFI BIOS UTILITY

The AMI UEFI BIOS provides users with a built-in Setup program to modify basic system configuration. All configured parameters are stored in a flash-backed-up to save the Setup information whenever the power is turned off.

3.1 Entering Setup

To enter the setup screens, follow the steps below:

1. Turn on the computer and press the key immediately.
2. After you press the key, the main BIOS setup menu displays. You can access the other setup screens from the main BIOS setup menu, such as the Advanced and Chipset menus.

3.2 The Main Menu

Once you enter the AMI BIOS Aptio Setup Utility, the Main Menu appears on the screen. In the Main Menu, there are several Setup functions and a couple of Exit options for your selection. Use Select Screen Keys (or Move Keys) to select the Setup Page you intend to configure then press <Enter> to accept or enter its sub-menu.

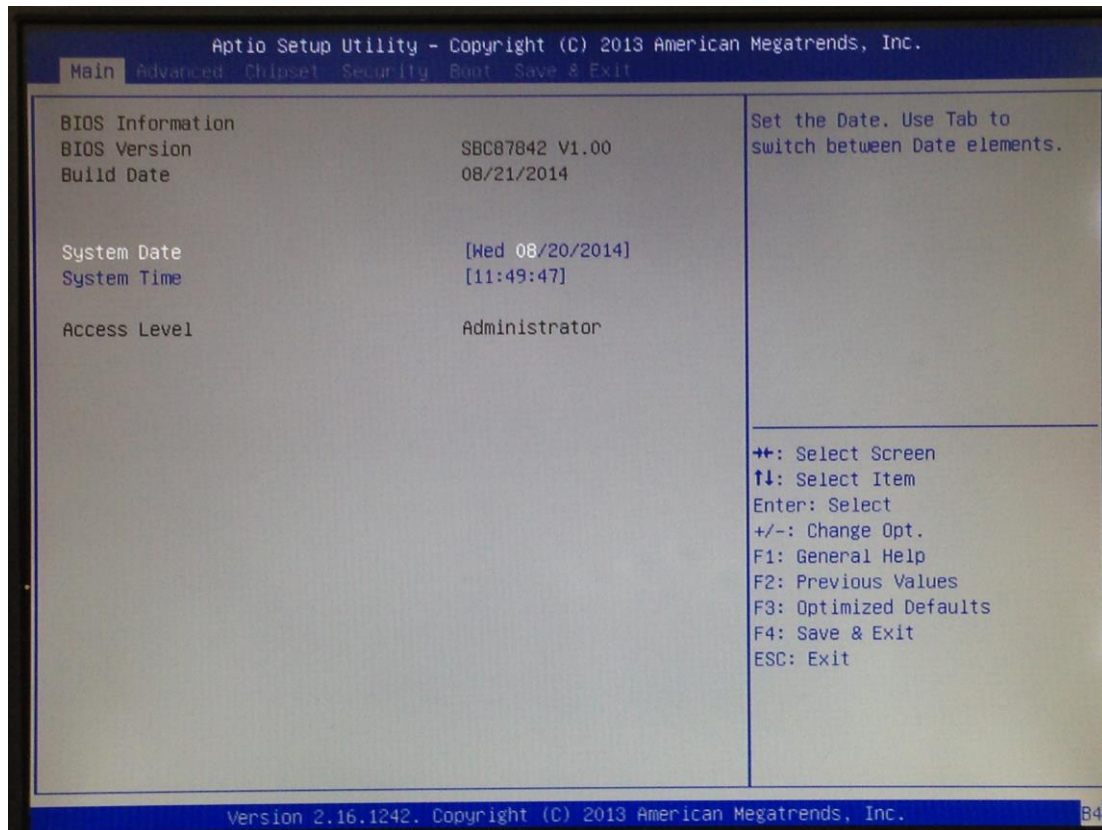

System Date

The date format is <day> <month> <date> <year>.

System Time

This item shows current time of your system with the format <hour> <minute> <second>. The time is calculated based on the 24-hour military-time clock. For example, 1 p.m. is 13:00:00.

3.3 Advanced Features

This Advanced section allows users to configure and improve your system, to set up some system features according to your preference. You can select any of the items in the left frame of the screen to go to the sub menus:

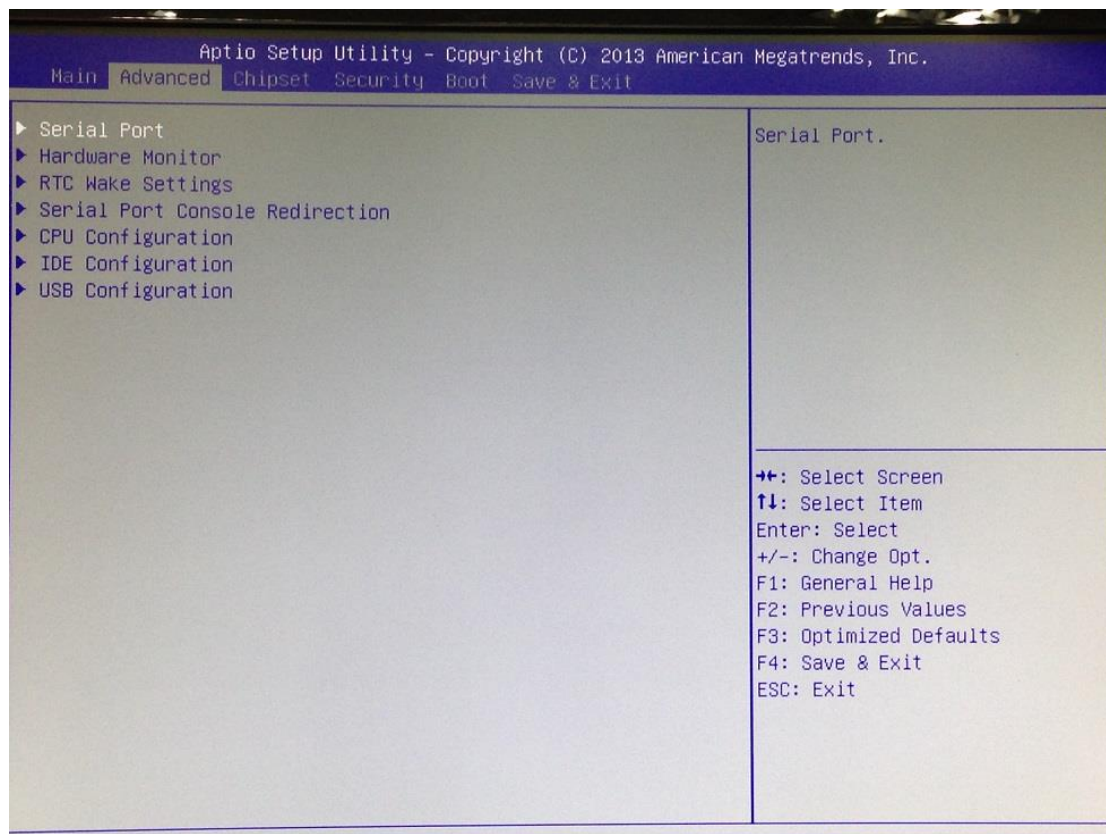

- **Serial Port Configuration**

The default setting for all Serial Ports are RS232.

You can change the setting by selecting the value you want in each COM Port Type.

Supports internal 120 ohms terminator in RS422 & RS485 mode.

(Please refer below graphics.)

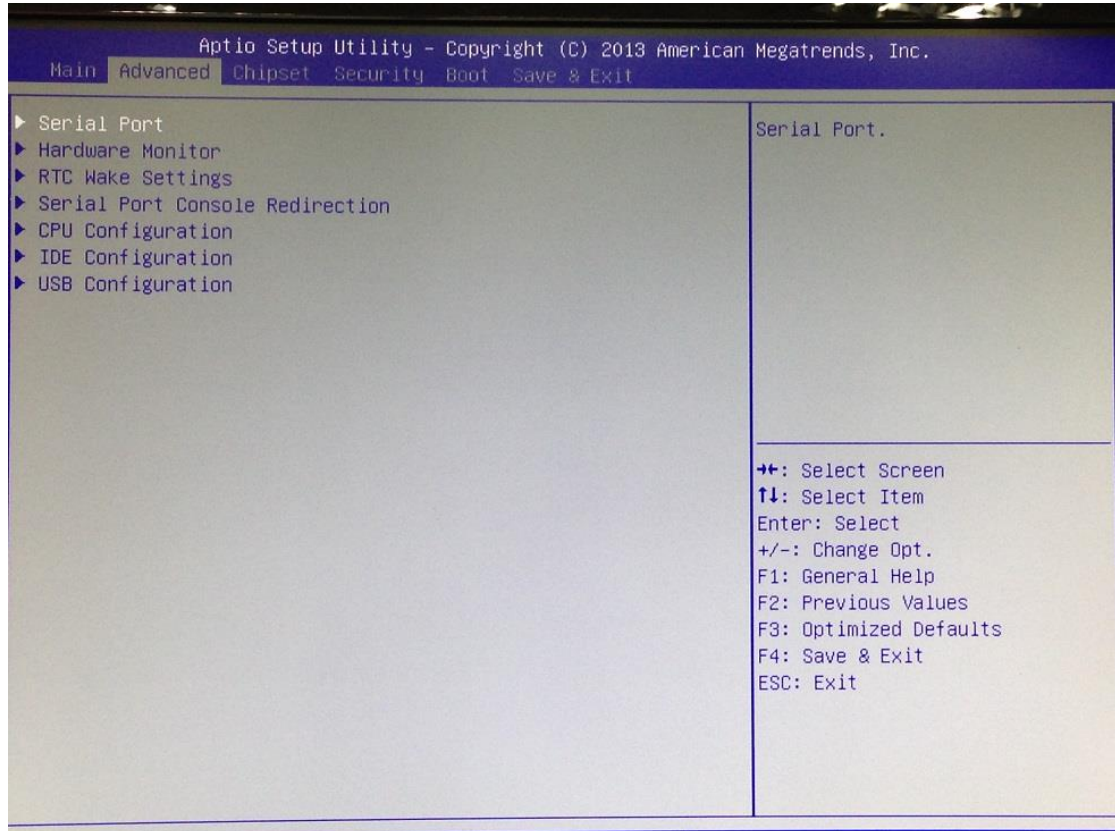

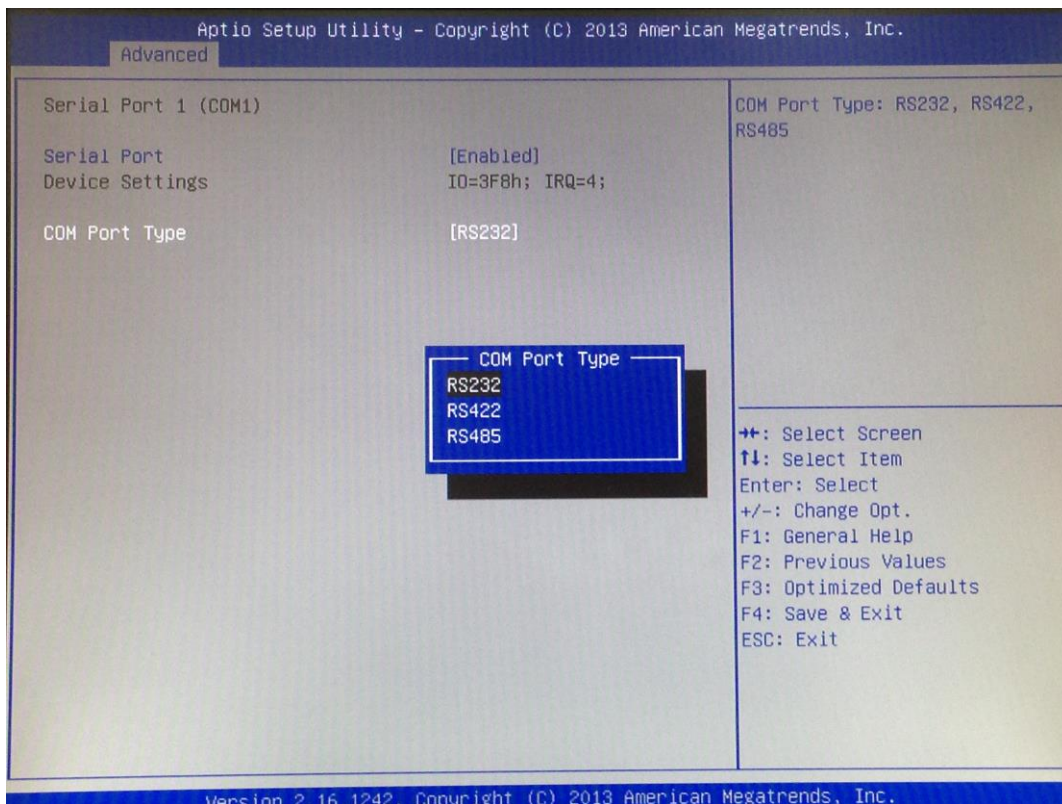
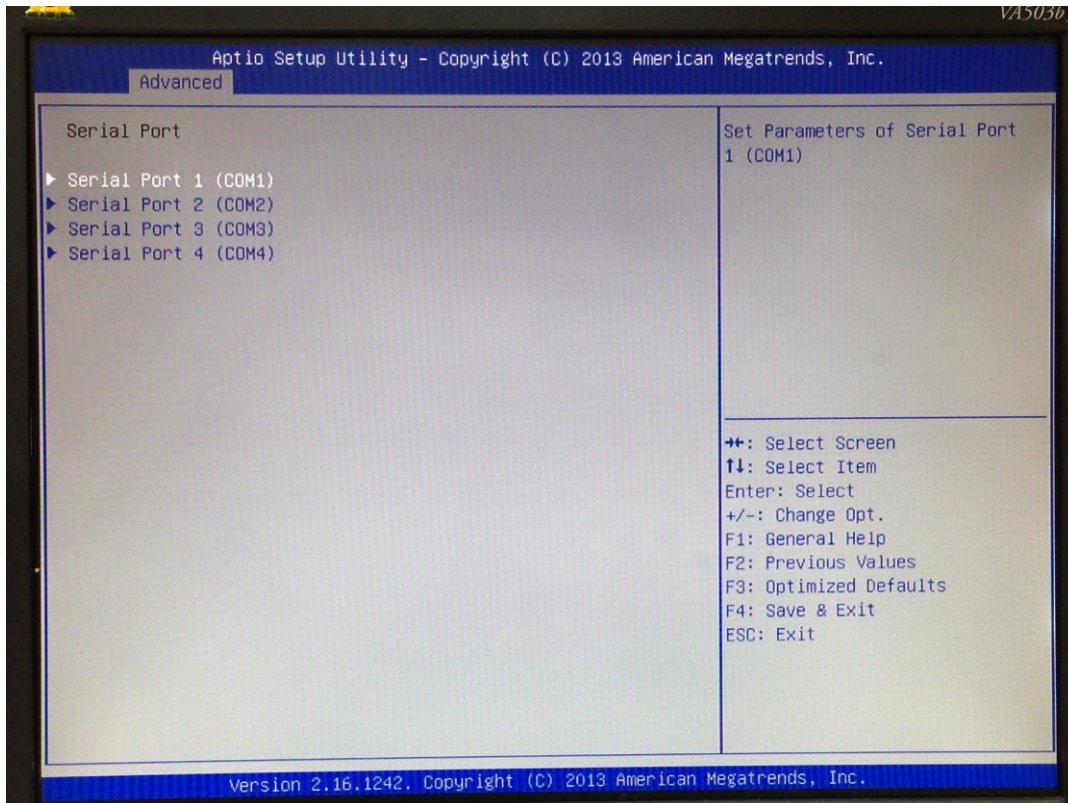

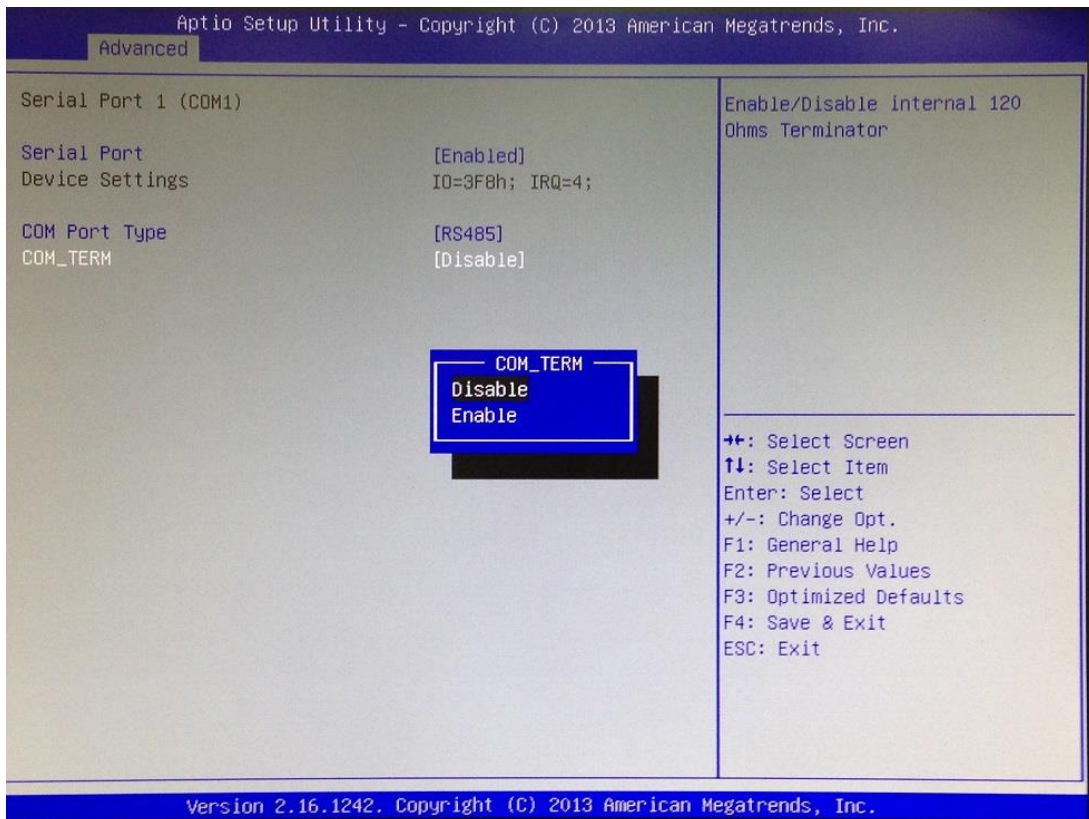
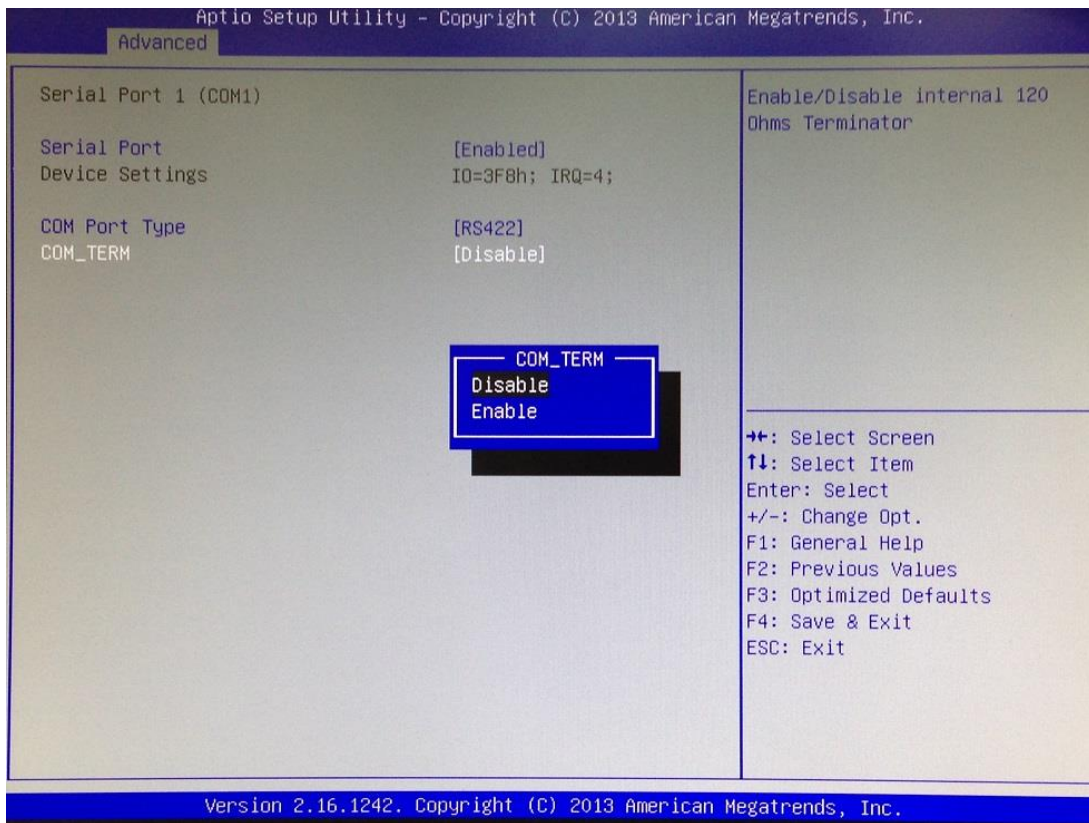

- **H/W Monitor**

Scroll to this item and press <Enter> to view the monitor hardware status.

(Please refer below graphics.)

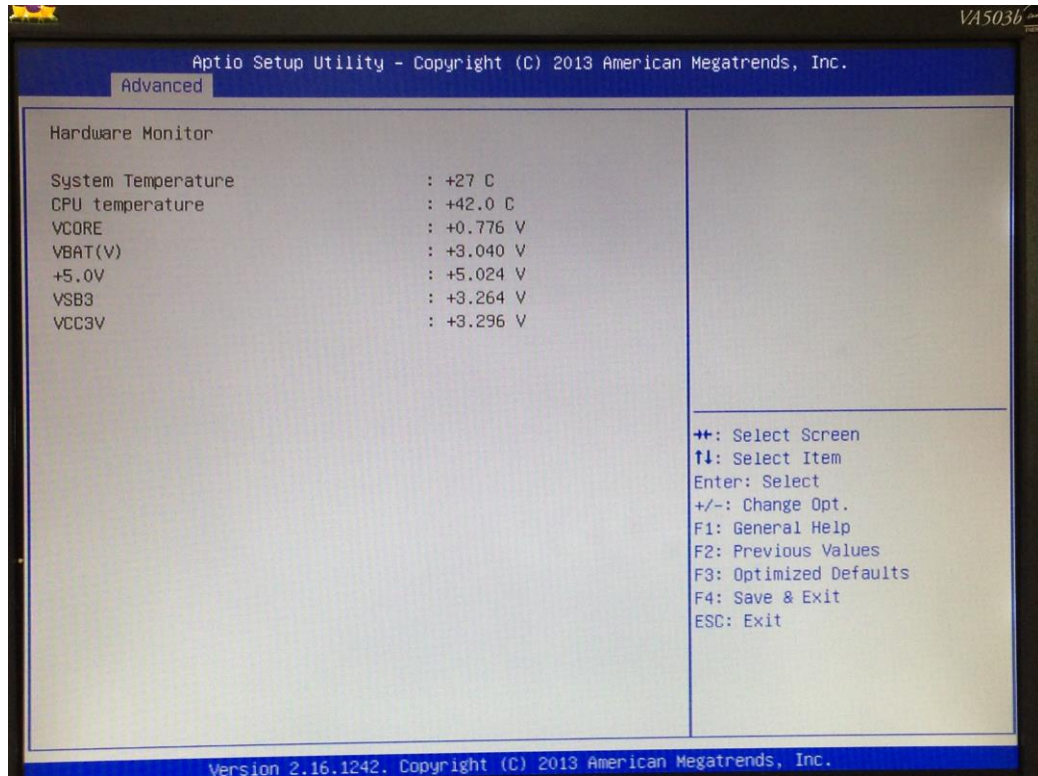
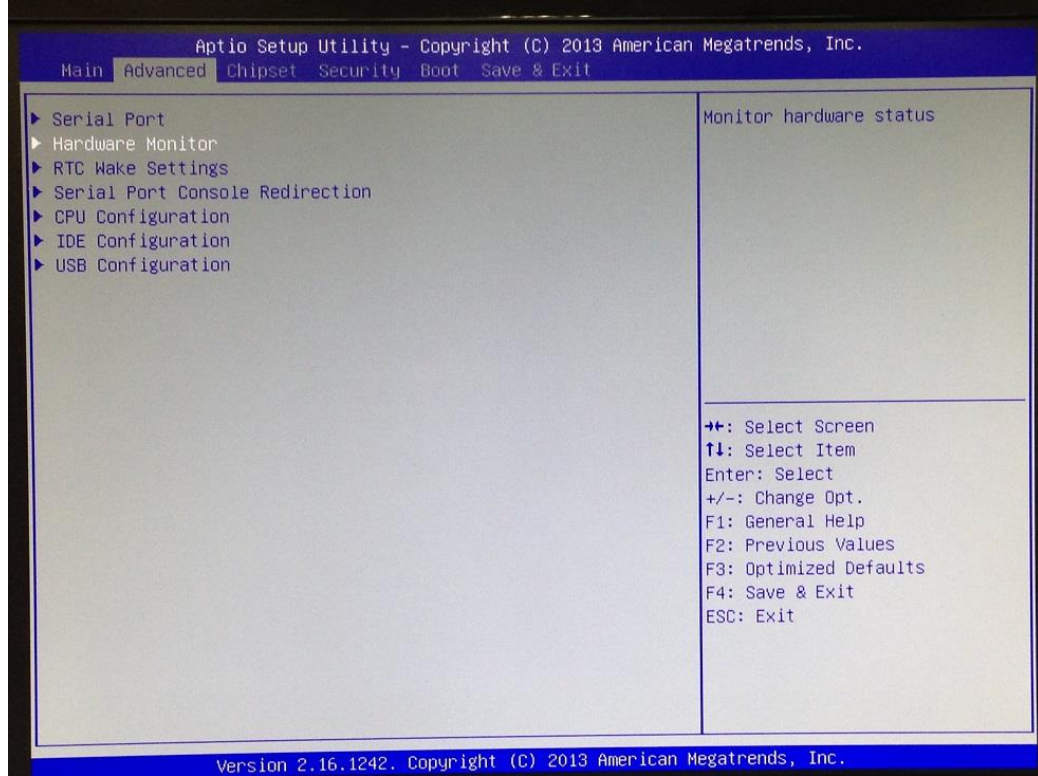

- **RTC Wake Settings**

The default setting is “disable”.

If the setting is changed for “enable”, you can set up the fixed time to boot up automatically.

(Please refer below graphics.)

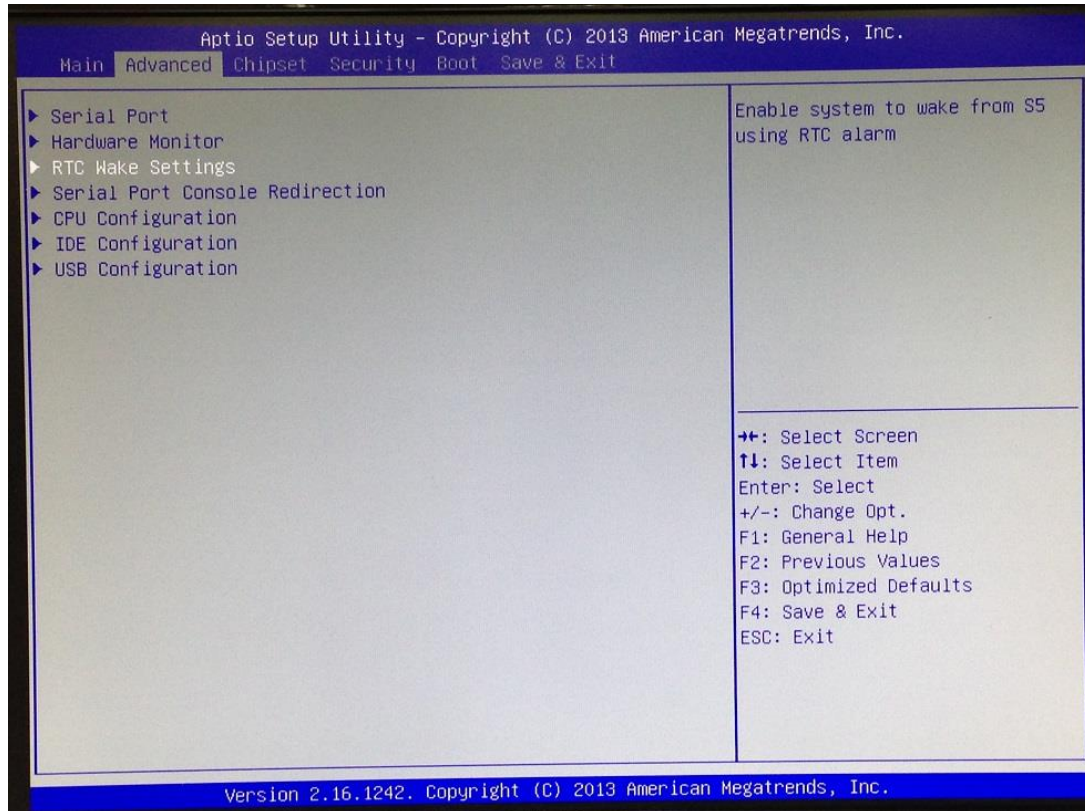

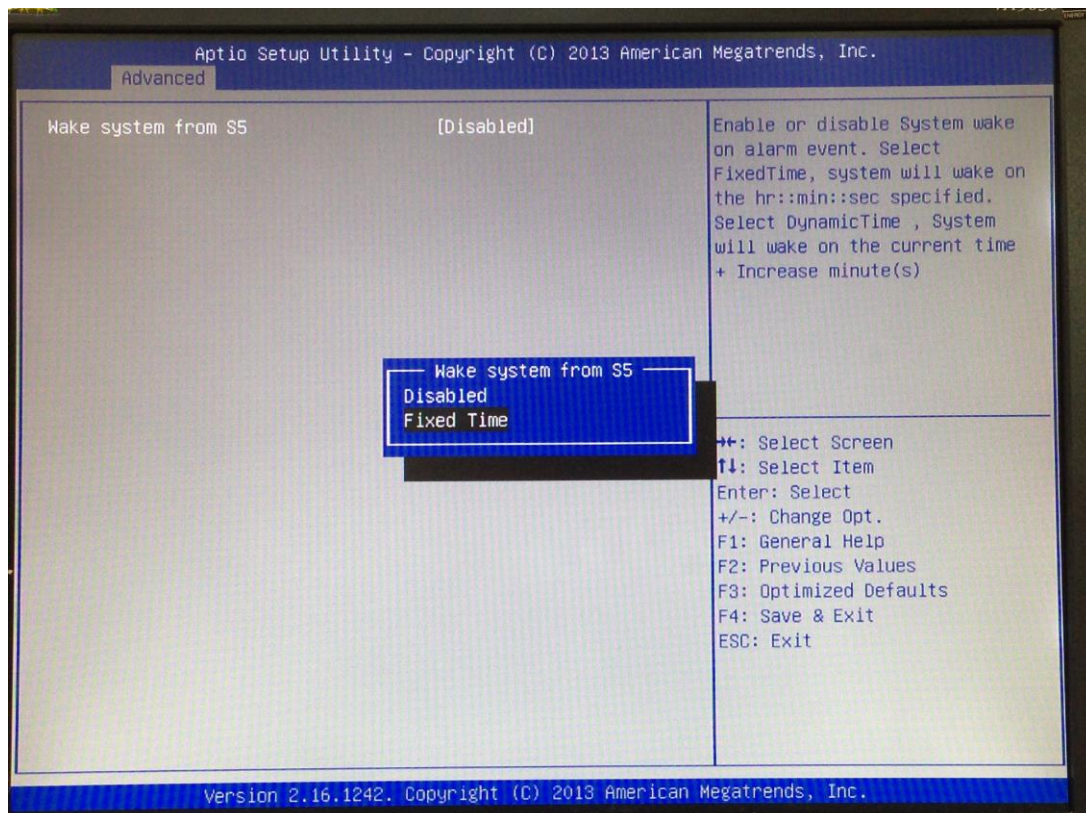
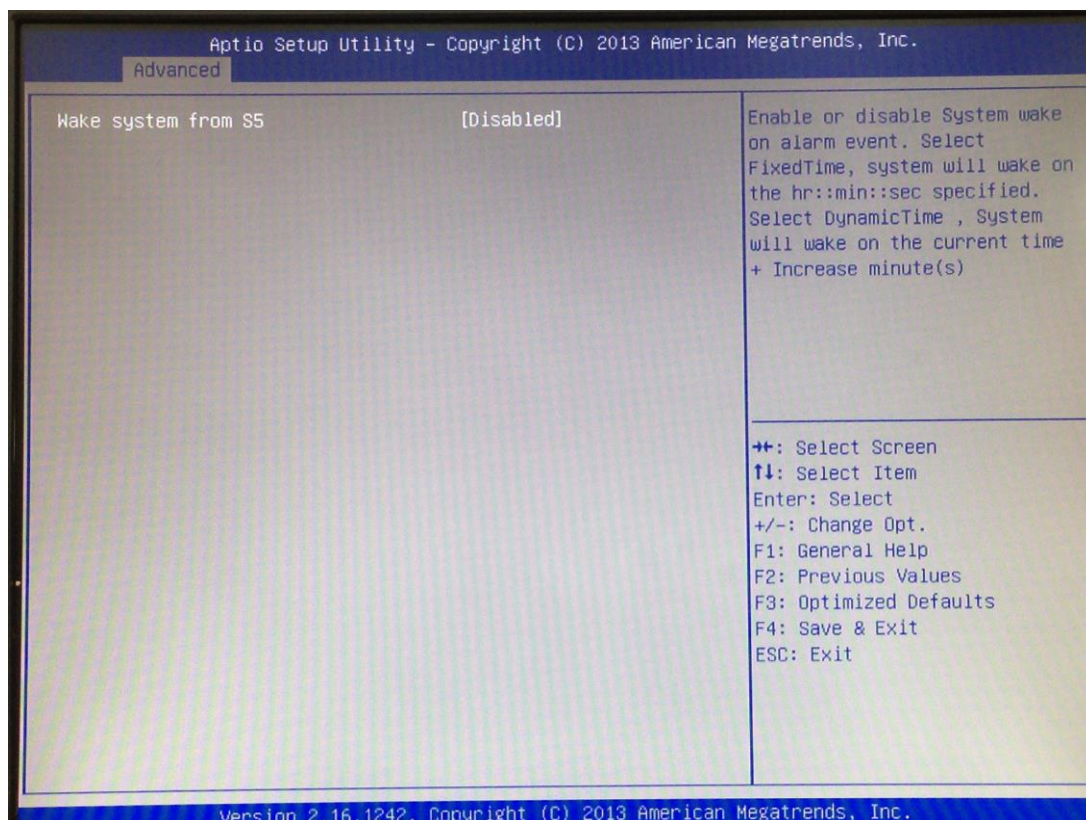

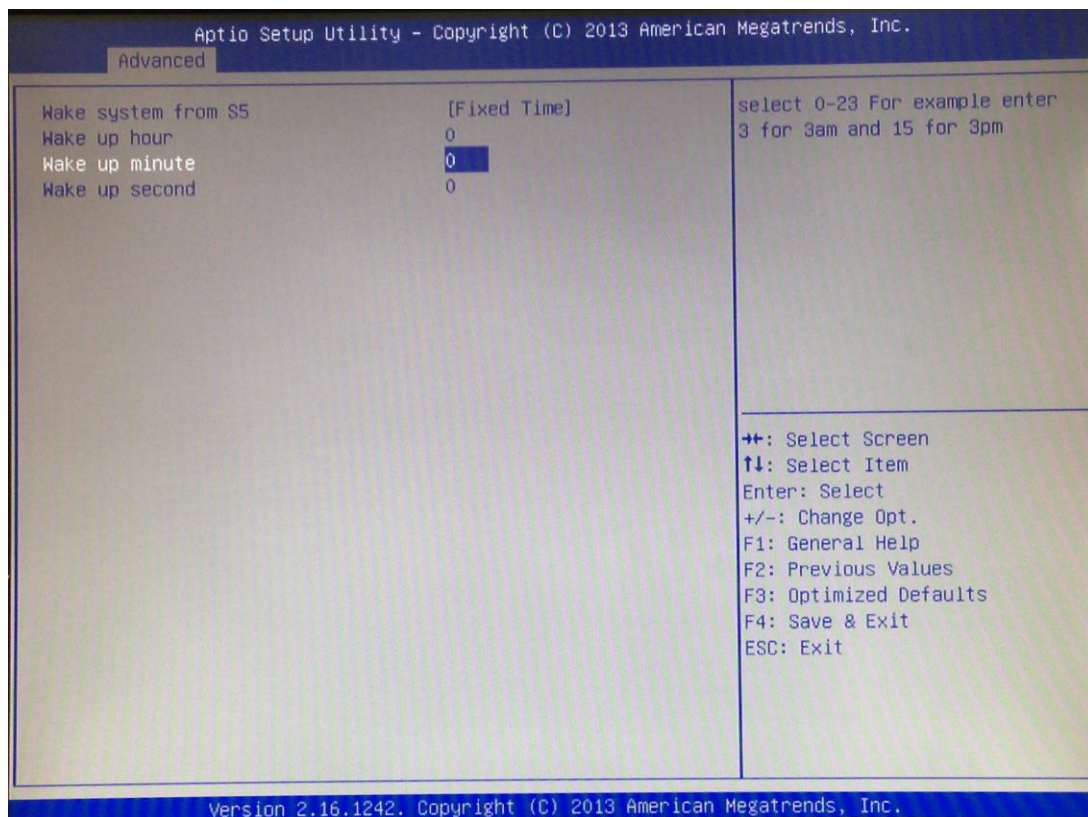
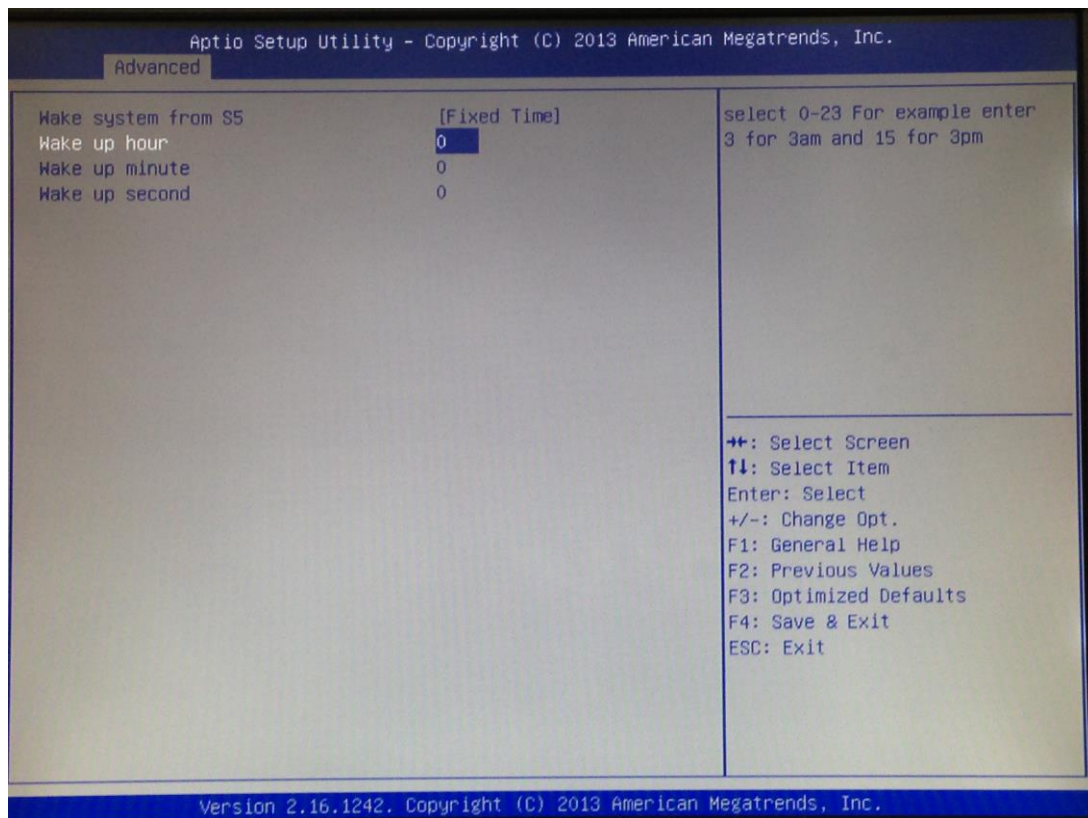

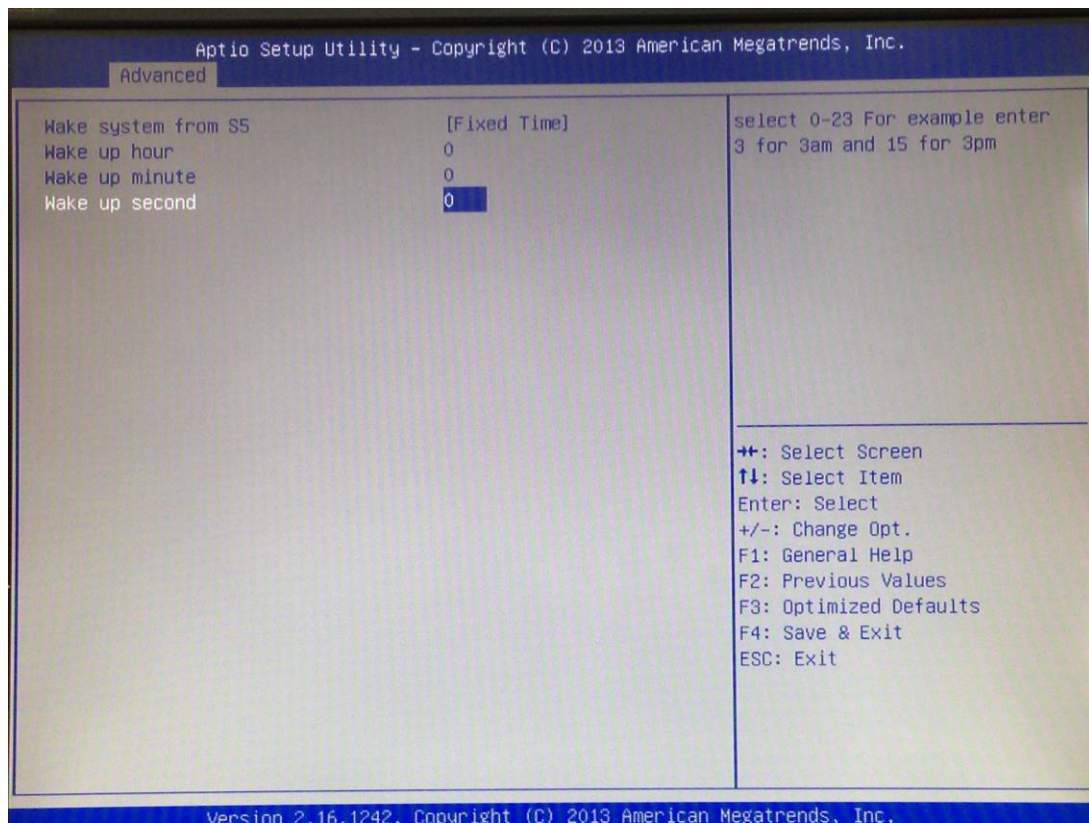

- **Serial Port Console Redirection**

Only COM1 has the console redirection function.

The default setting for the console redirection function is [Disabled]

(Please refer below graphics.)

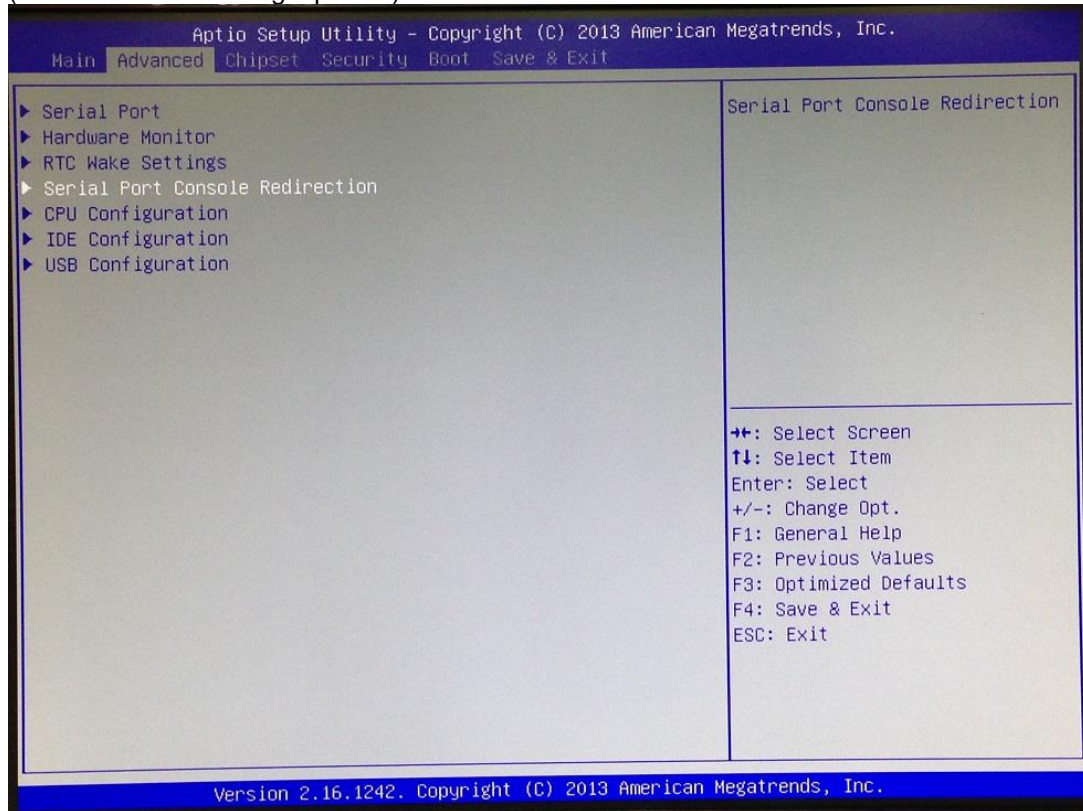

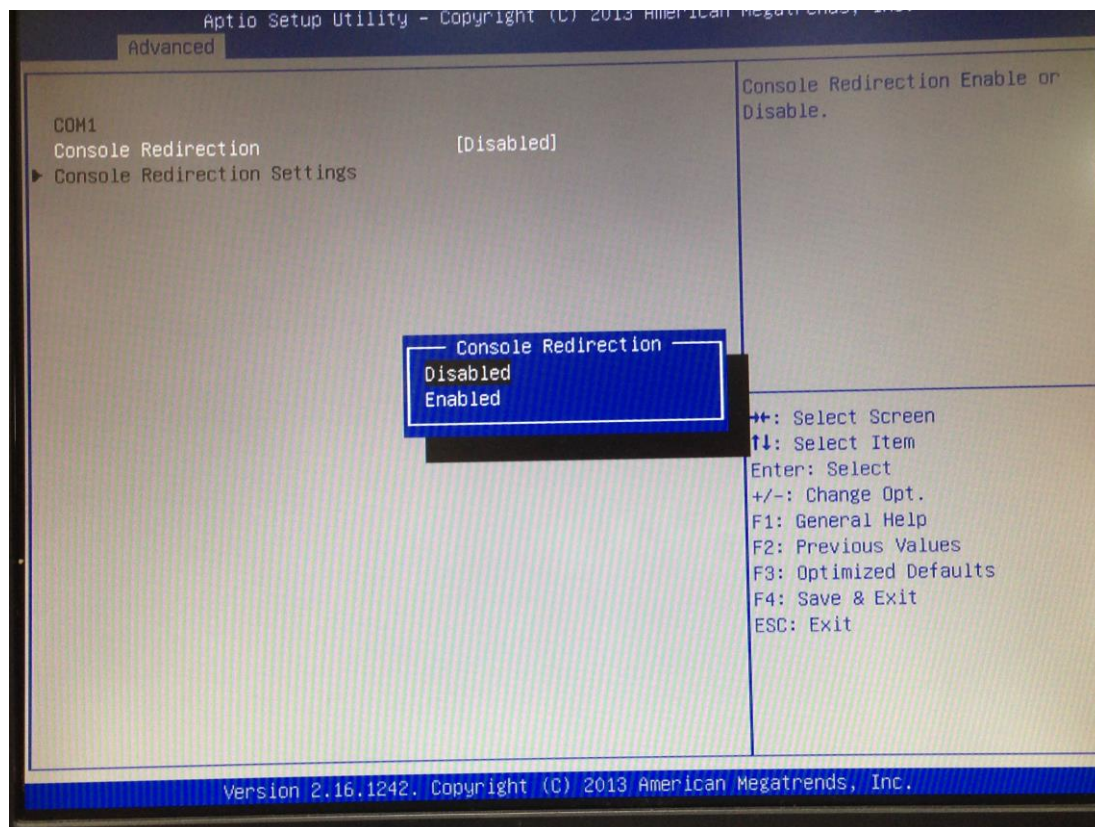

If the setting for the console redirection function is changed for [Enabled], the settings specify how the host computer and the remote computer (which the user is using) will exchange data. Both computers should have the same or compatible settings.

And you can further change the setting by selecting or setting the value you want in each function as the following pictures.

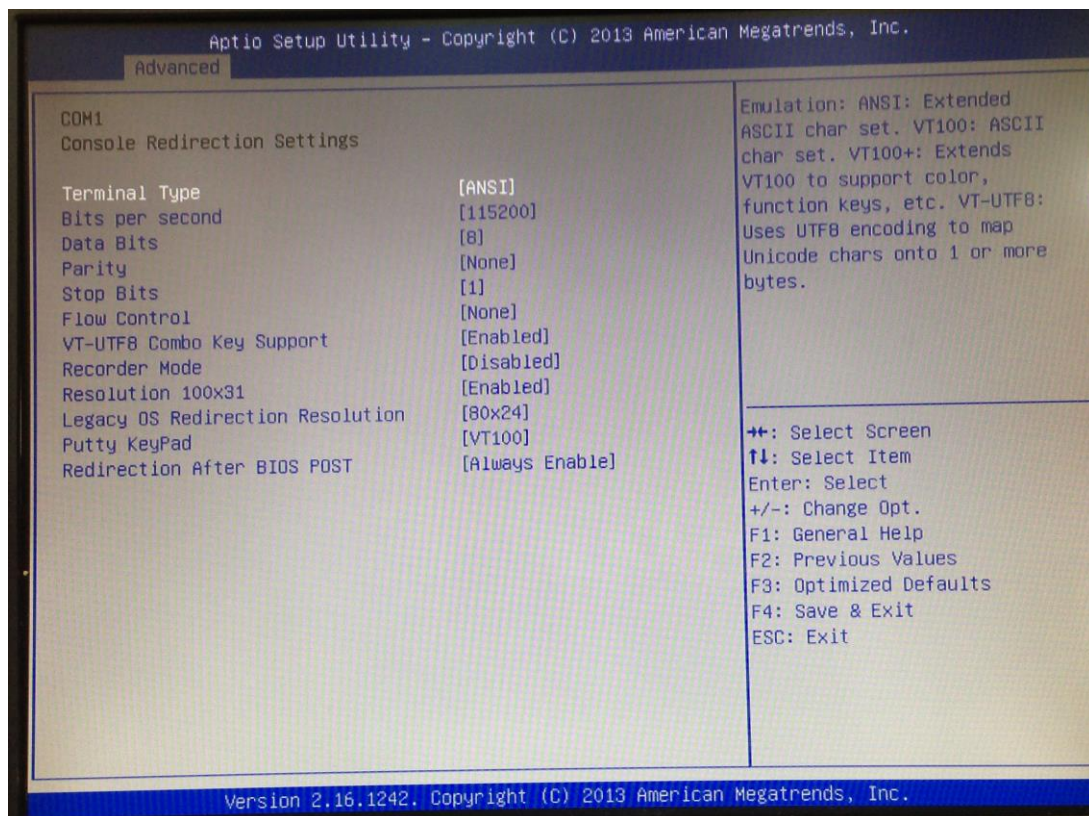
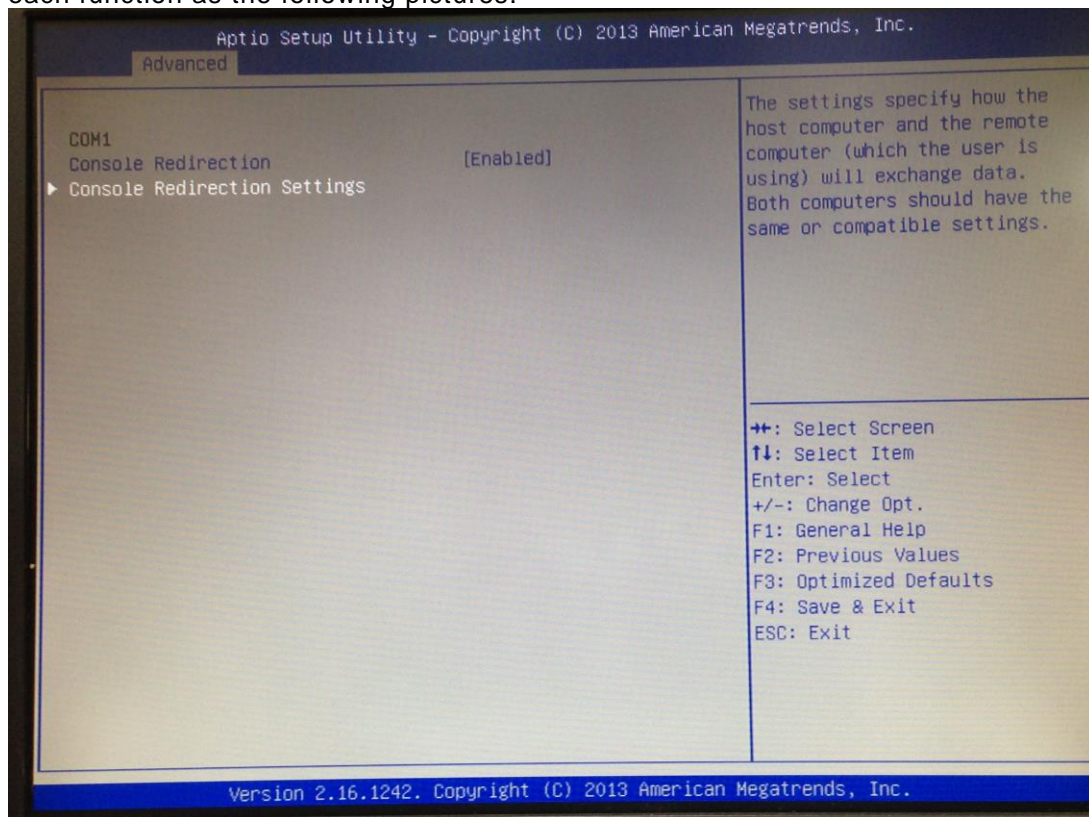

● **CPU Configuration**

Scroll to this item and press <Enter> to view the CPU Configuration informations.

(Please refer below graphics.)

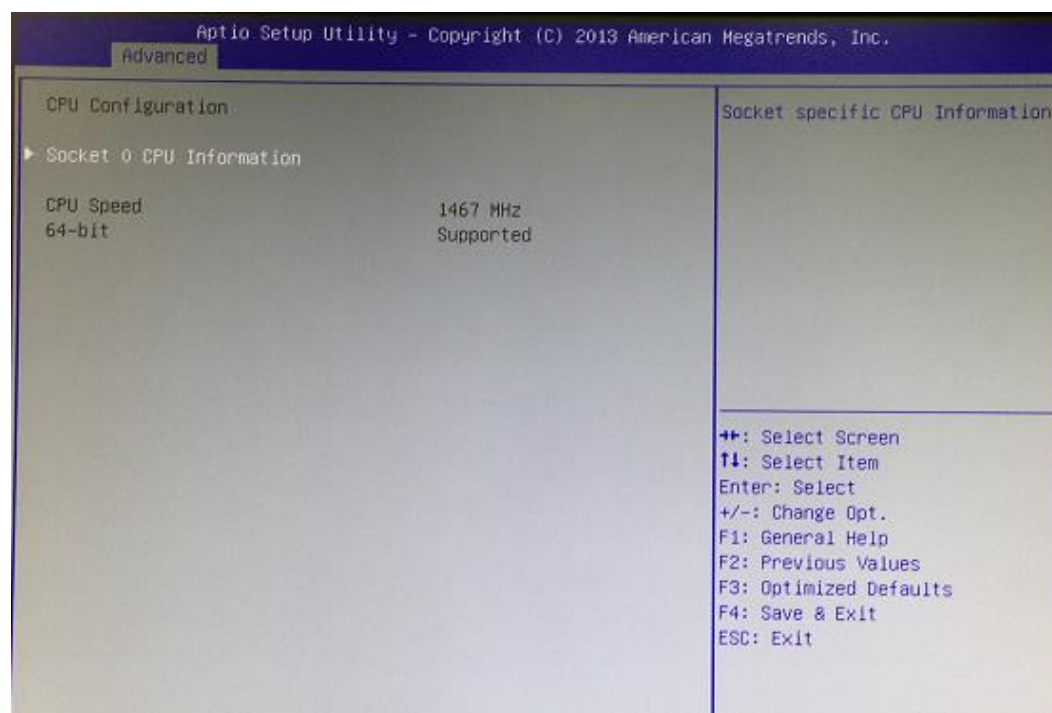
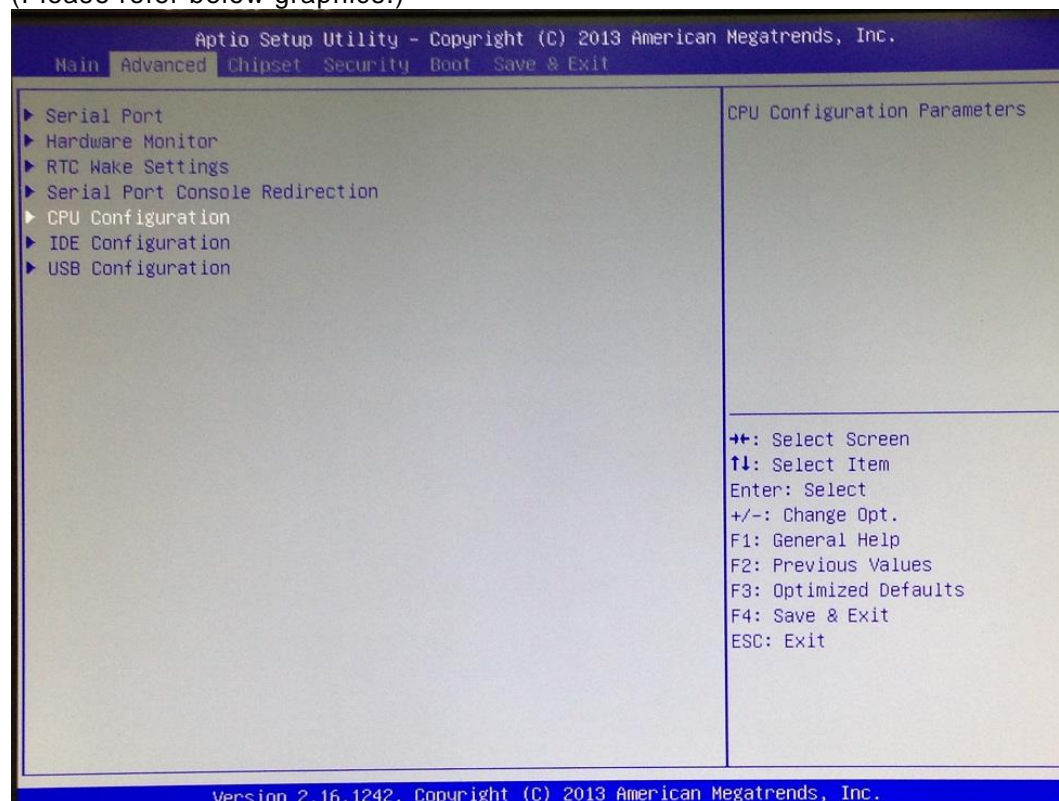

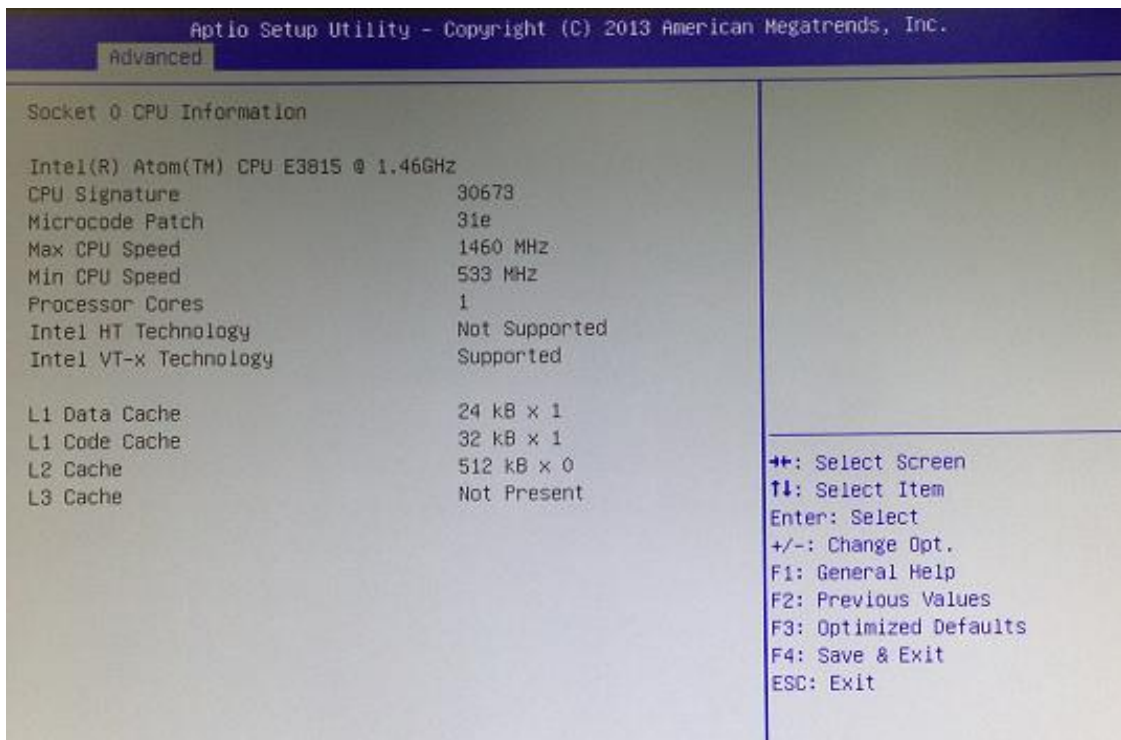

- **IDE Configuration**

Scroll to this item and press <Enter> to view the IDE Configuration informations.

(Please refer below graphics.)

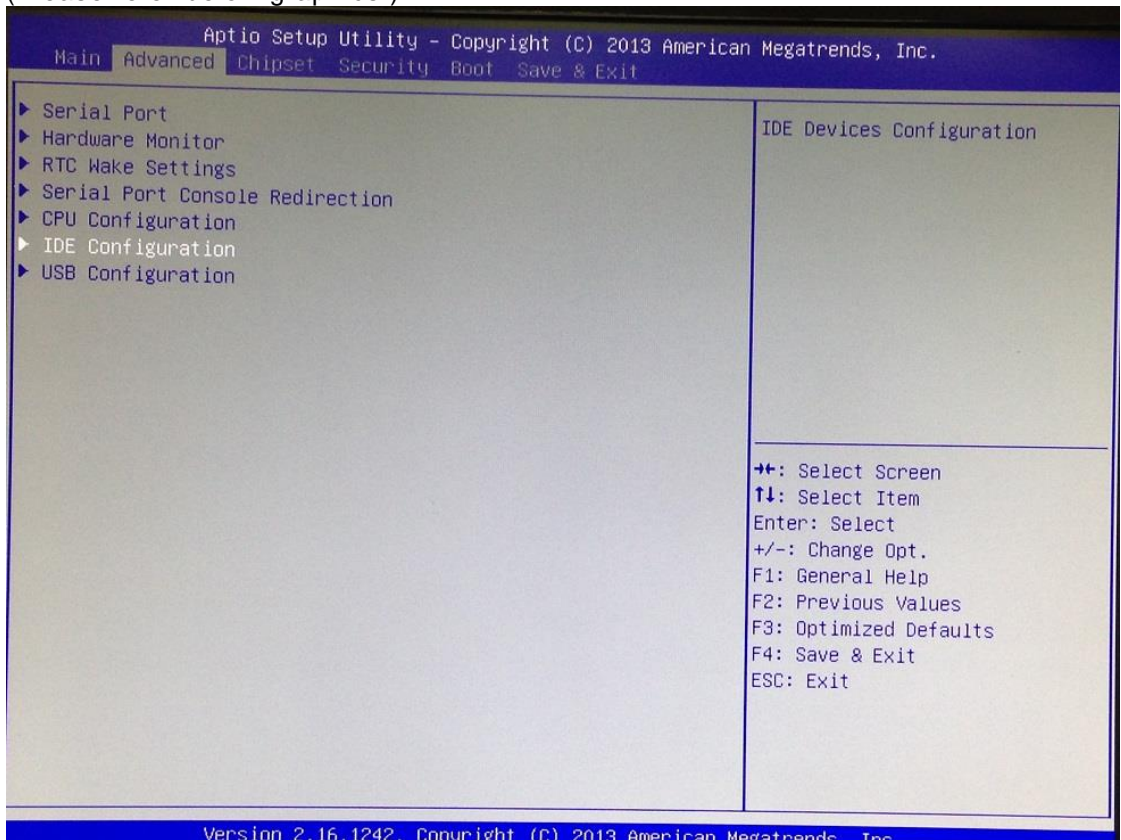

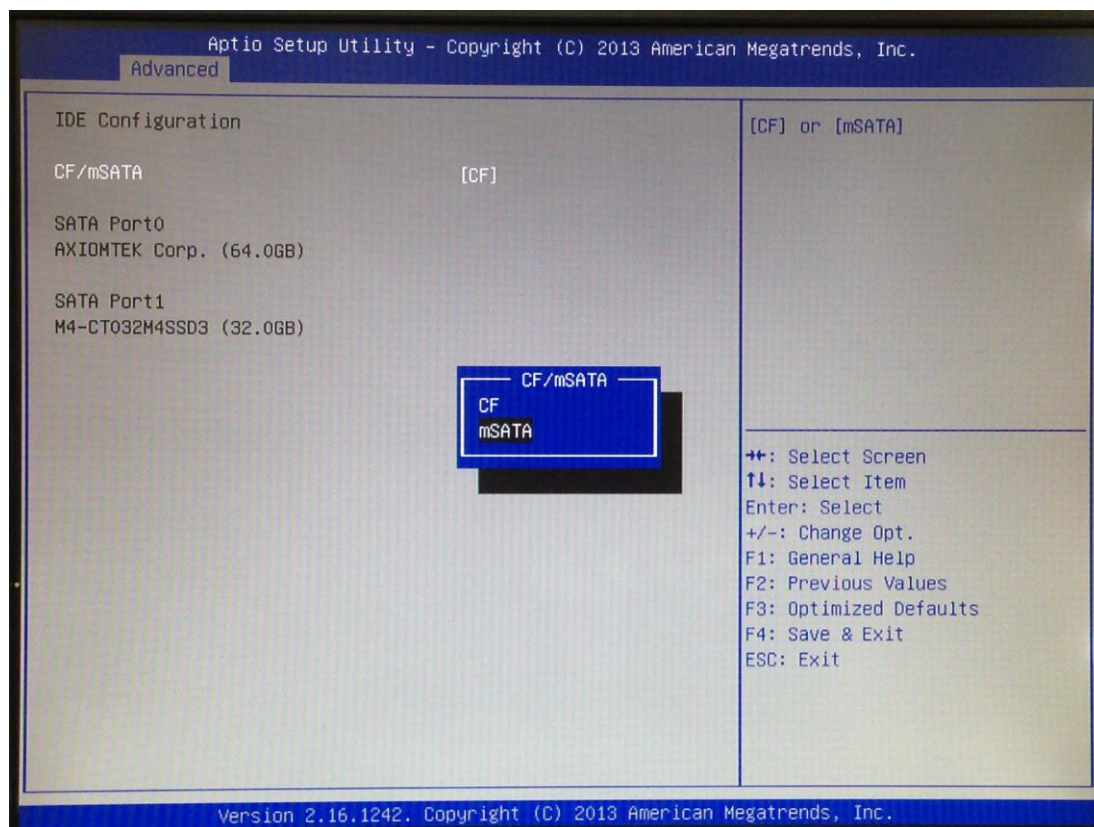

Note: CF and mSATA function can be either one, it can be select by BIOS menu. mSATA and wireless use the same slot, and only one of them can be selected.

- **USB Configuration**

Scroll to this item and press <Enter> to view the USB Configuration informations.

(Please refer below graphics.)

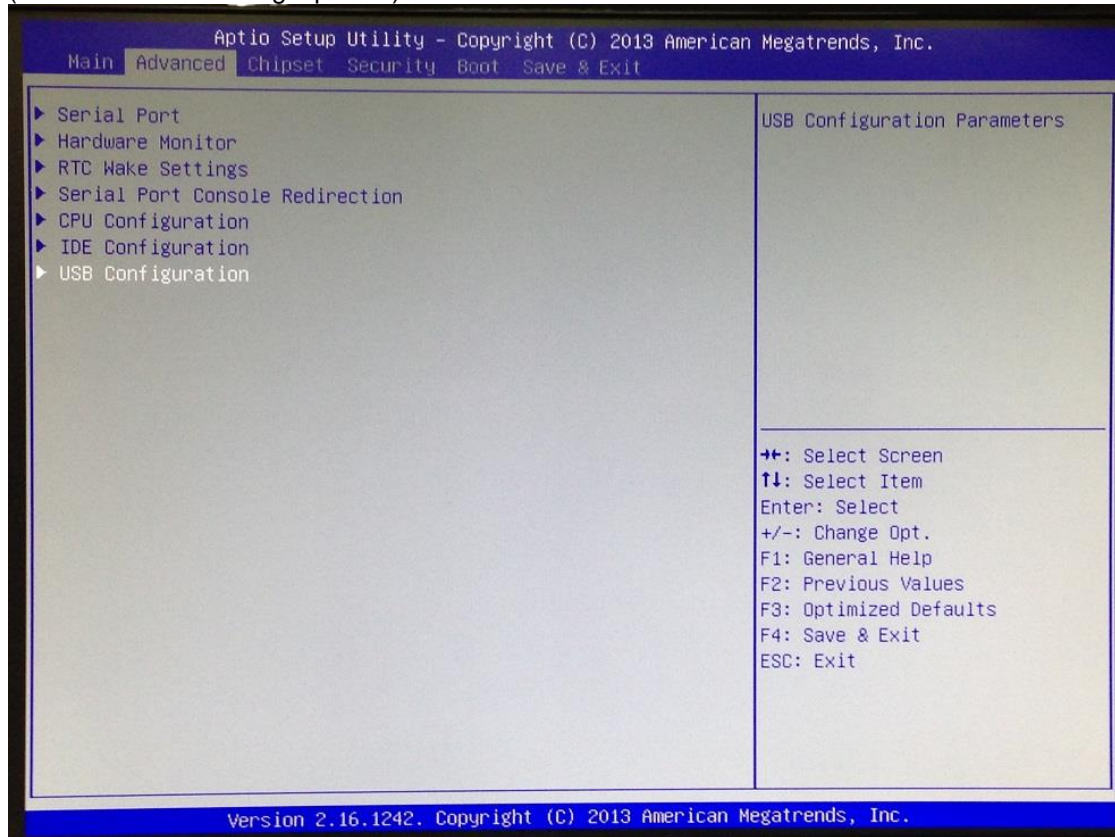

3.4 Chipset Feature

This section contains completely optimized chipset's features in the system

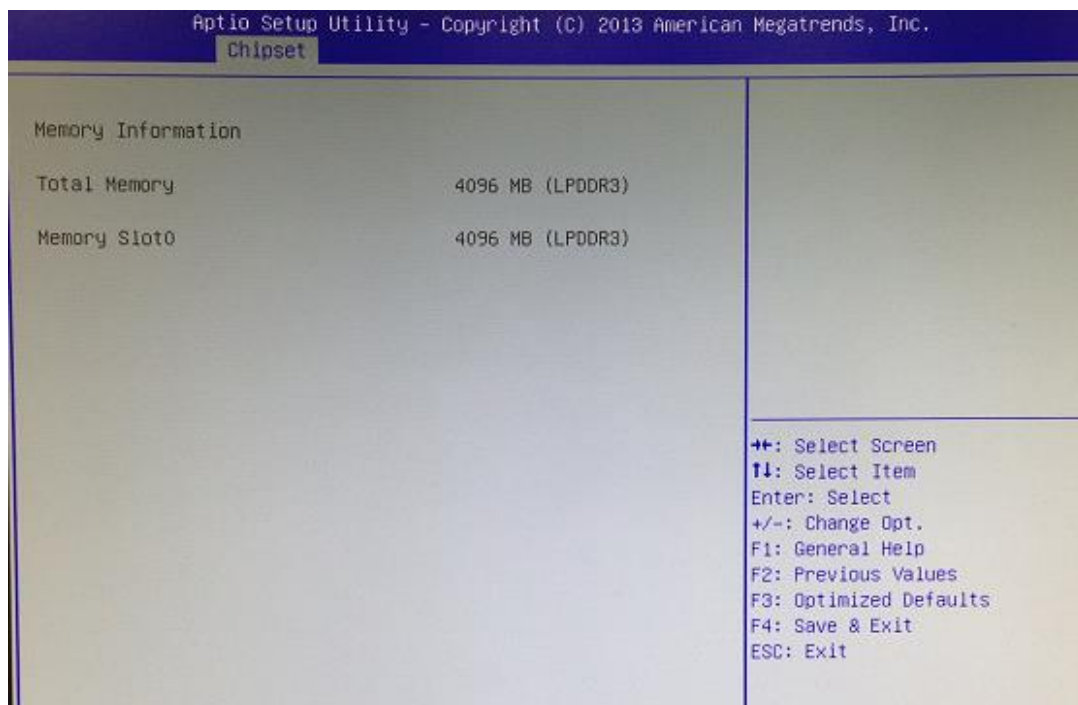
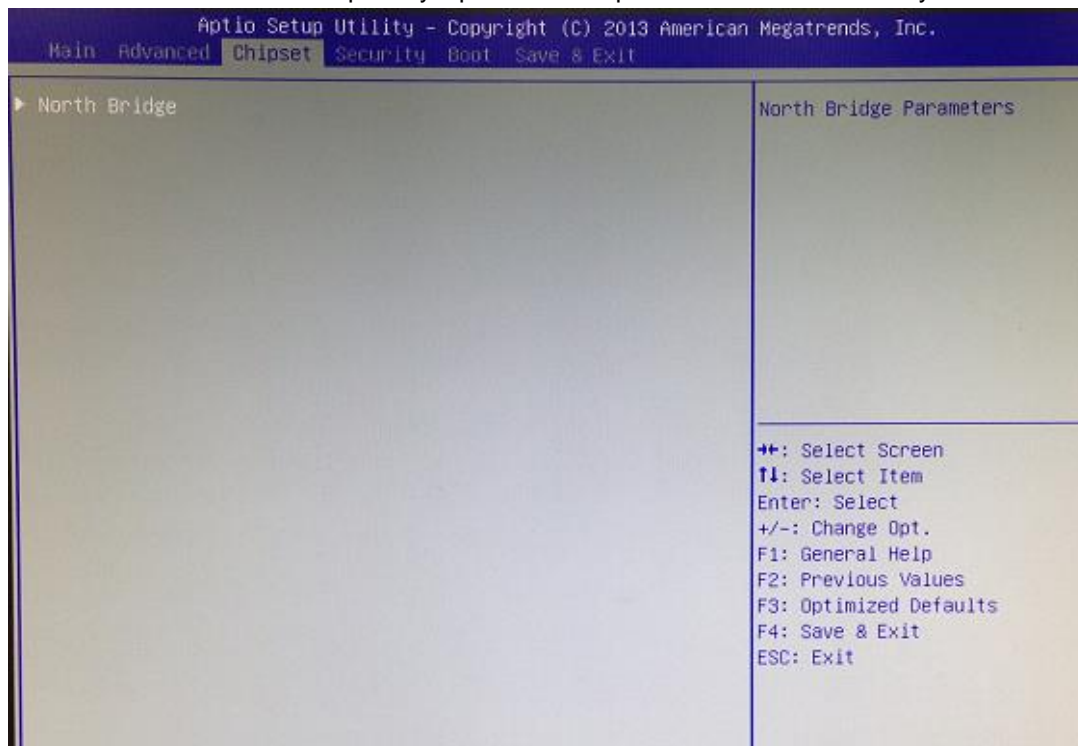

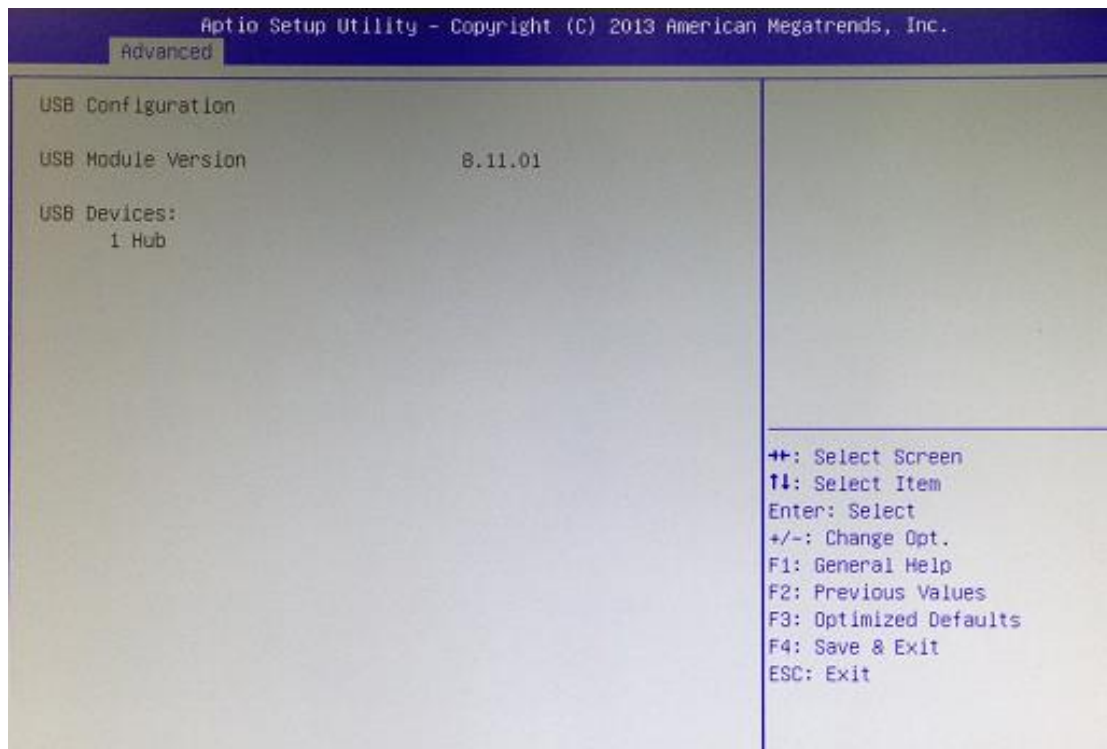

3.5 Security

The default setting for Administrator Password is “Not setting passwords”.

The Security menu allows users to change the security settings for the system.

You can set the password for both Administrator Password and User Password.

(Please refer below graphics.)

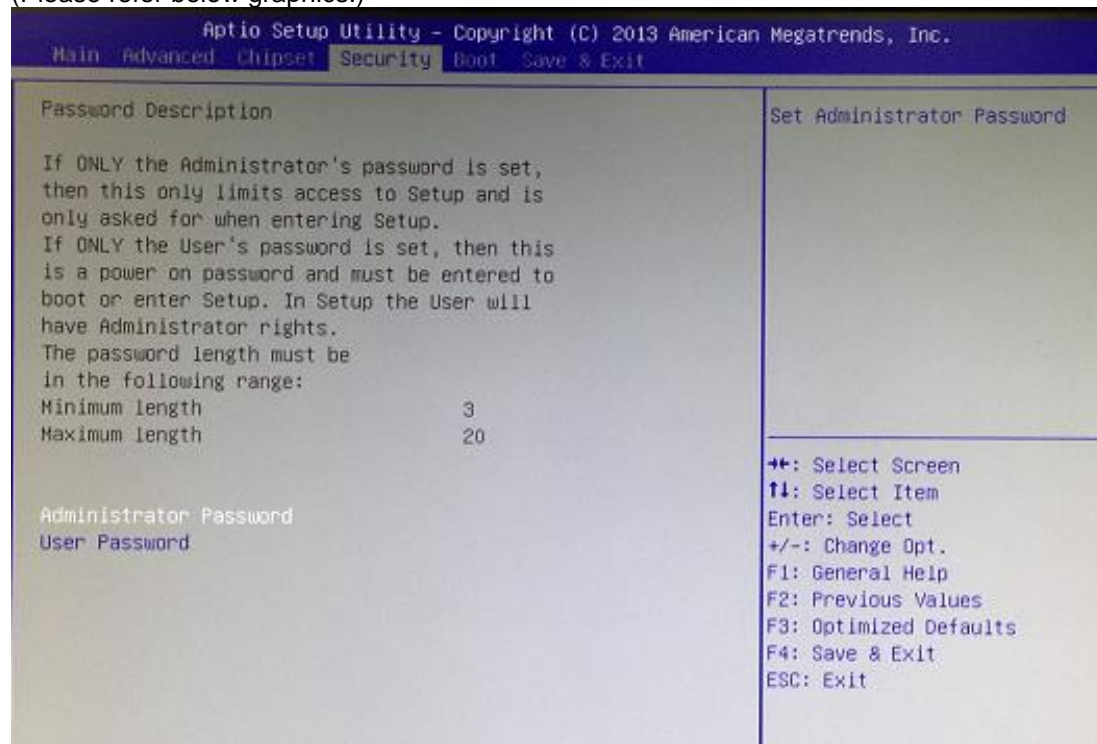

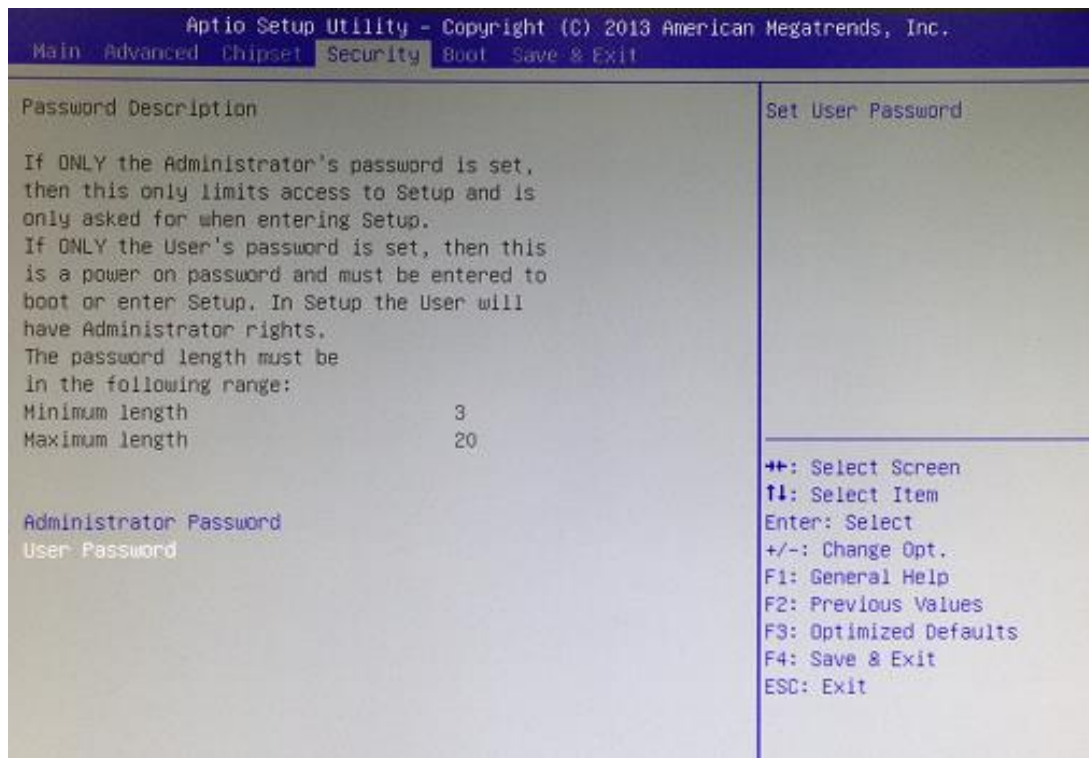

 **Note:** The BIOS default has no password, when user created the password, please remember the password number, if users forget password the RMA is the only solution.

3.6 Boot Type

The default setting boot from onboard LAN PxE Rom is [Disabled]

(Please refer below graphics.)

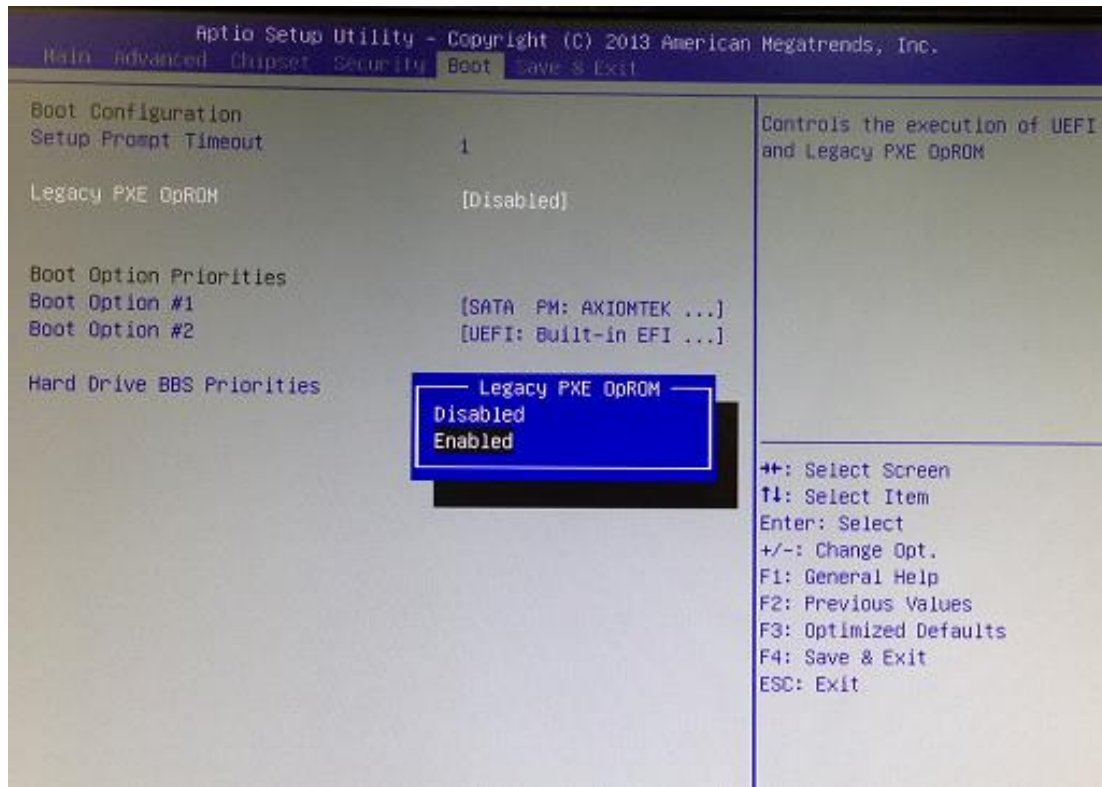
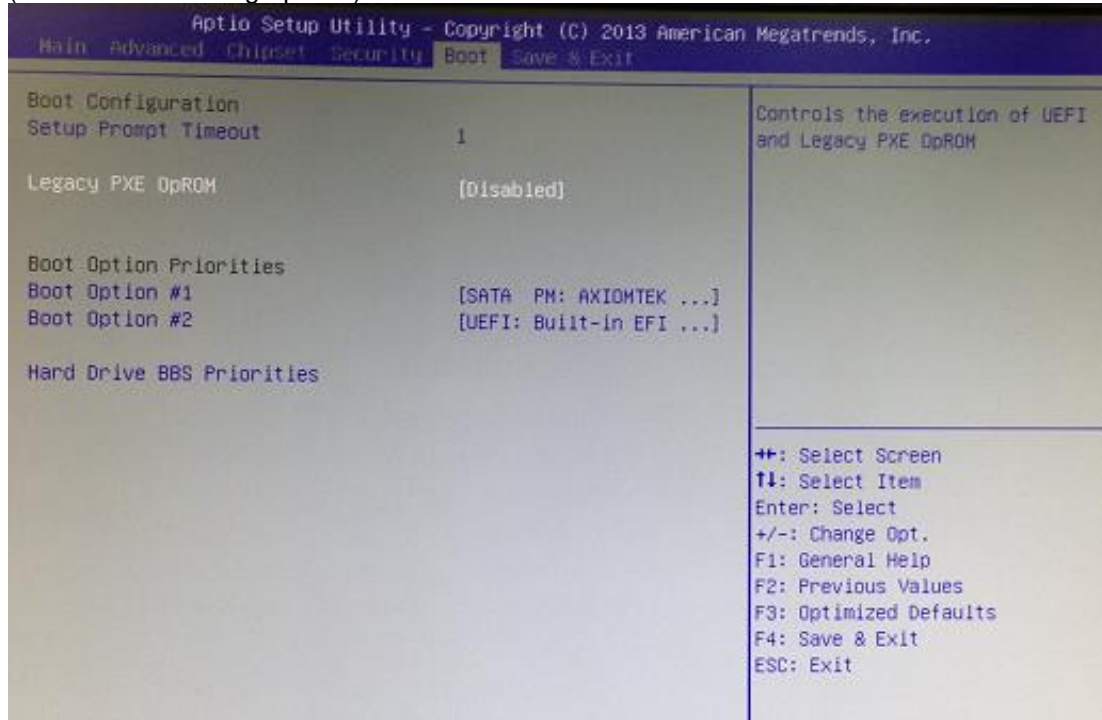

The Boot Option Priorities can select by Boot Option #1, #2...

(Please refer below graphics.)

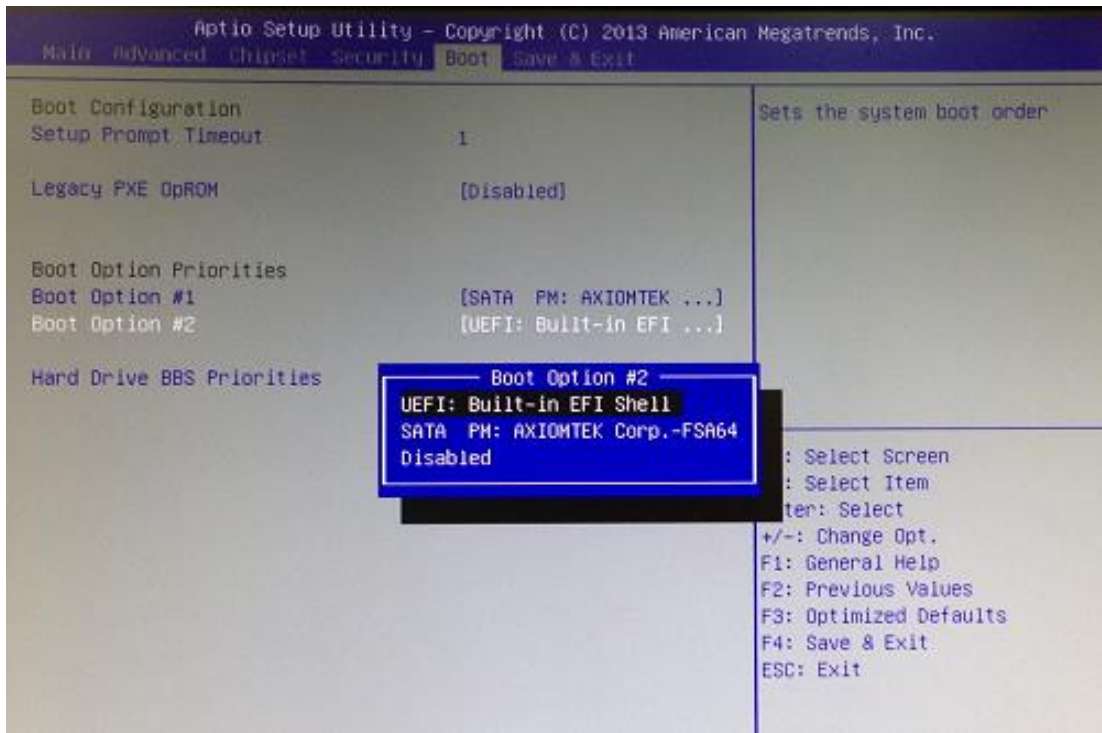
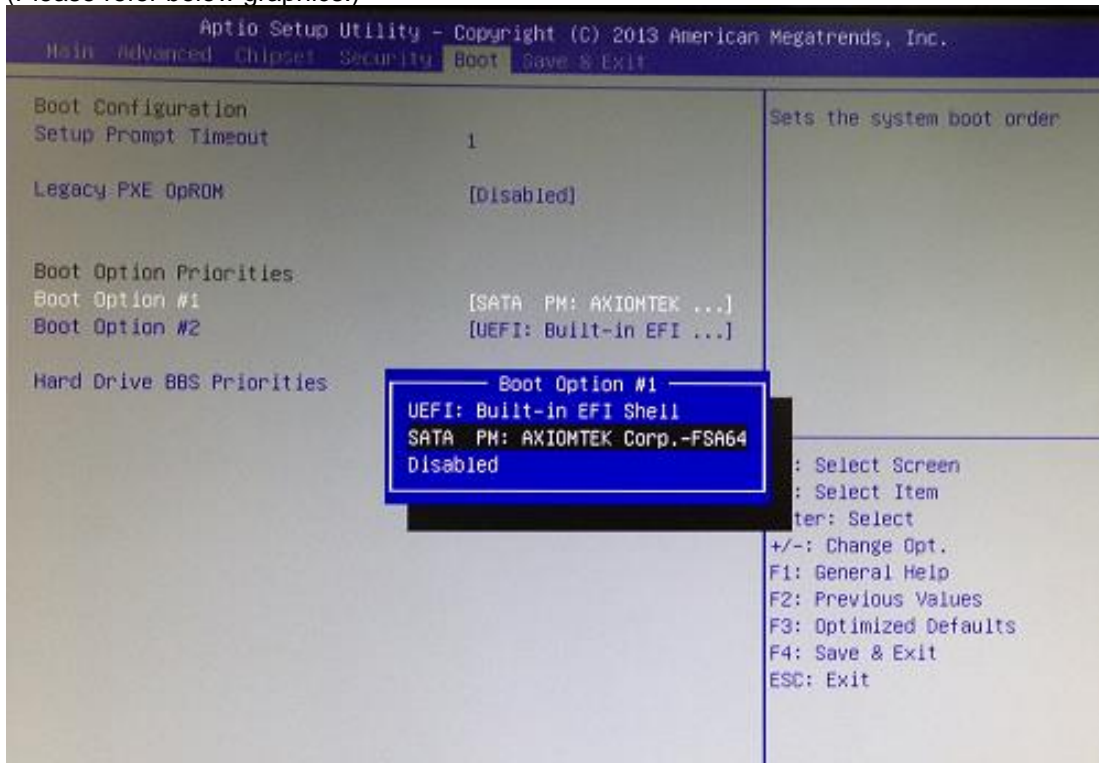

Hard Drive BBS Priorities supports the hard drive boot option.

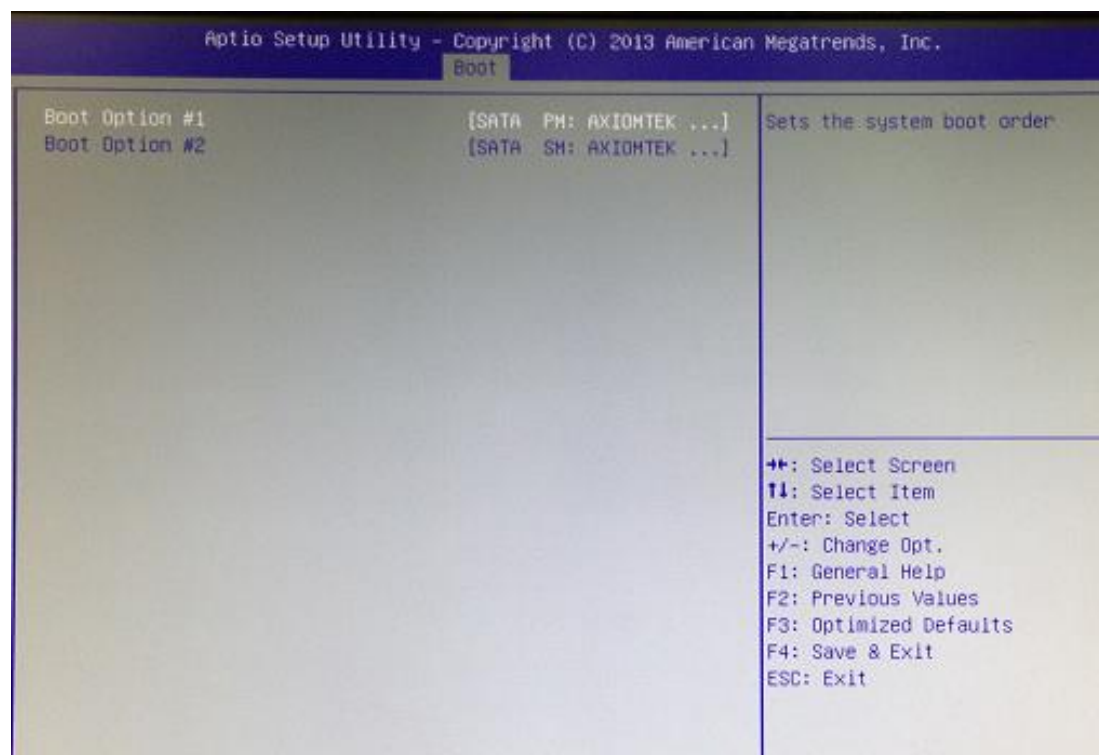
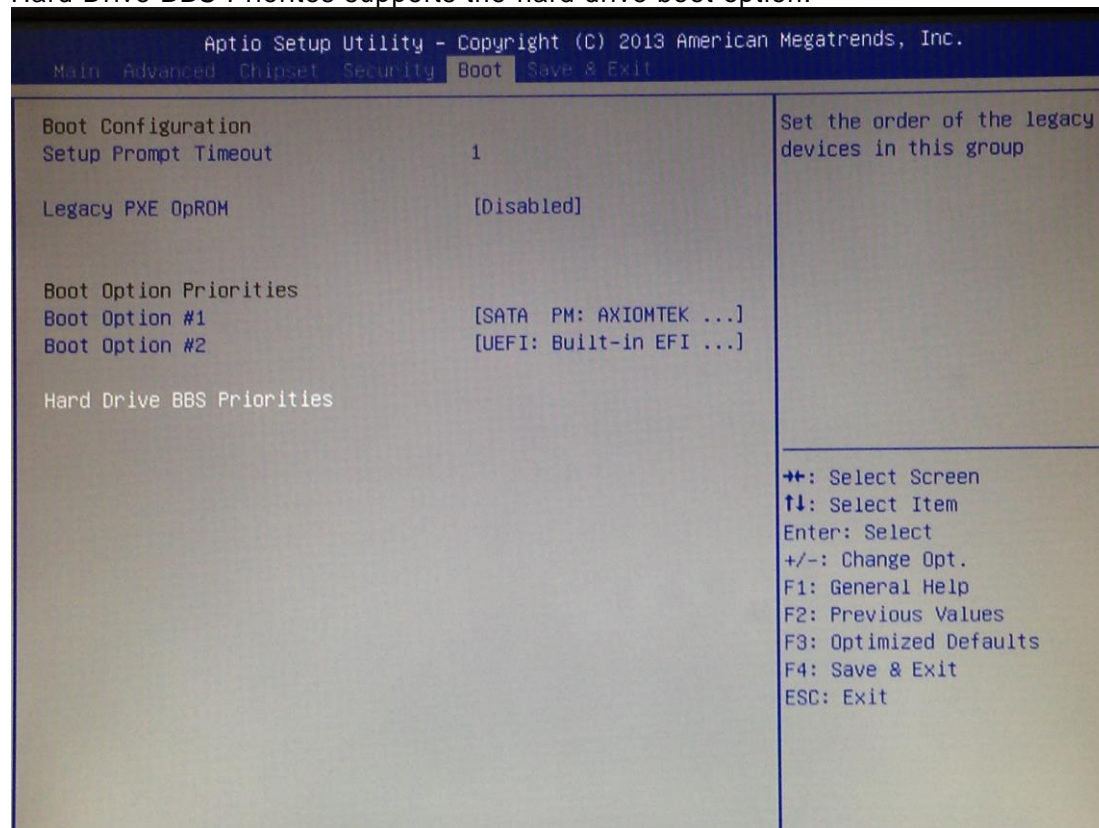

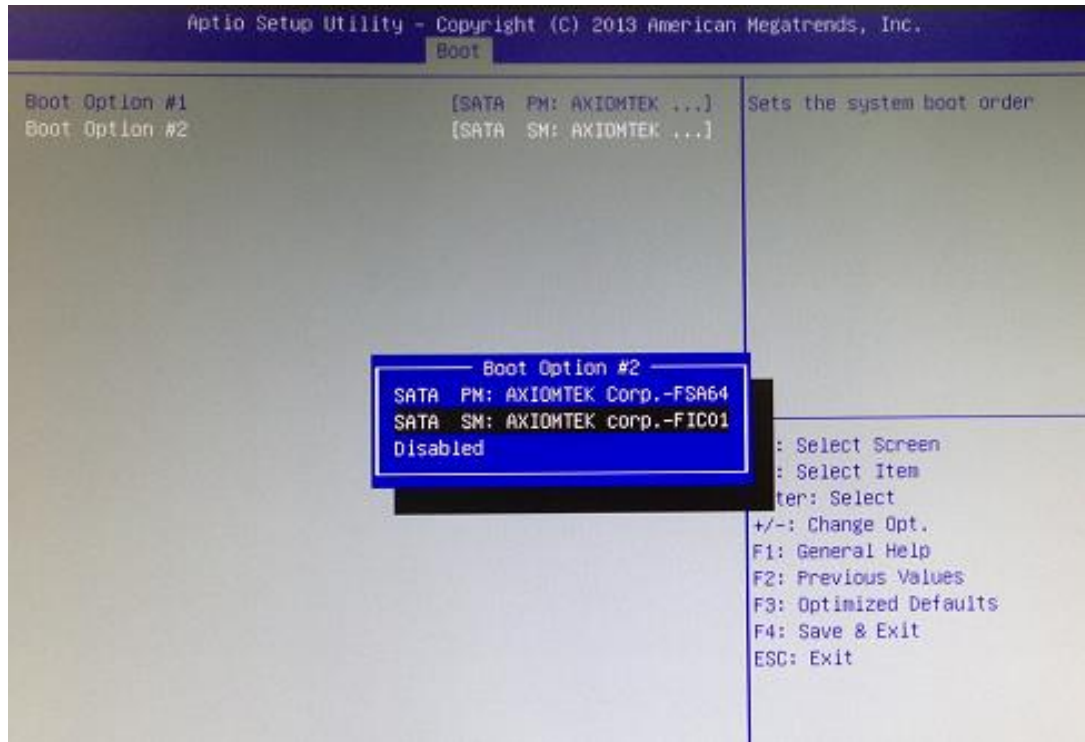

3.7 Save & Exit

This section allows you to determine whether or not to accept your modifications. Type “Y” to quit the setup utility and save all changes. Type “N” to bring you back to the Previous Setup utility.

(Please refer below graphics.)

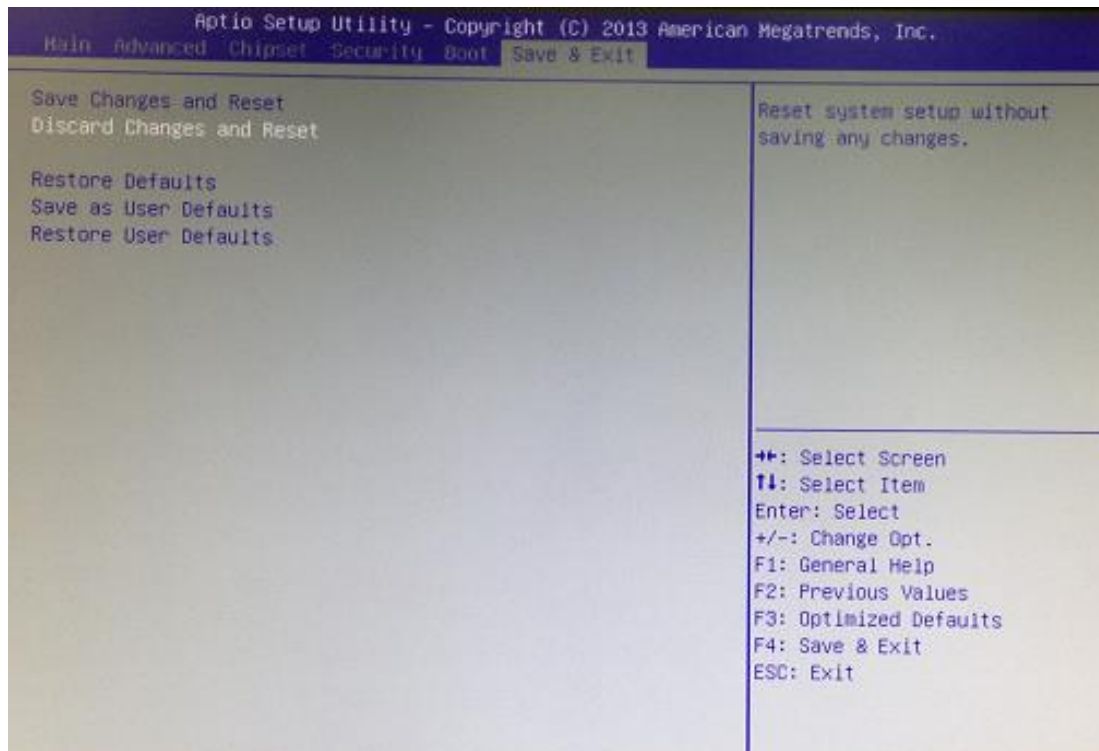
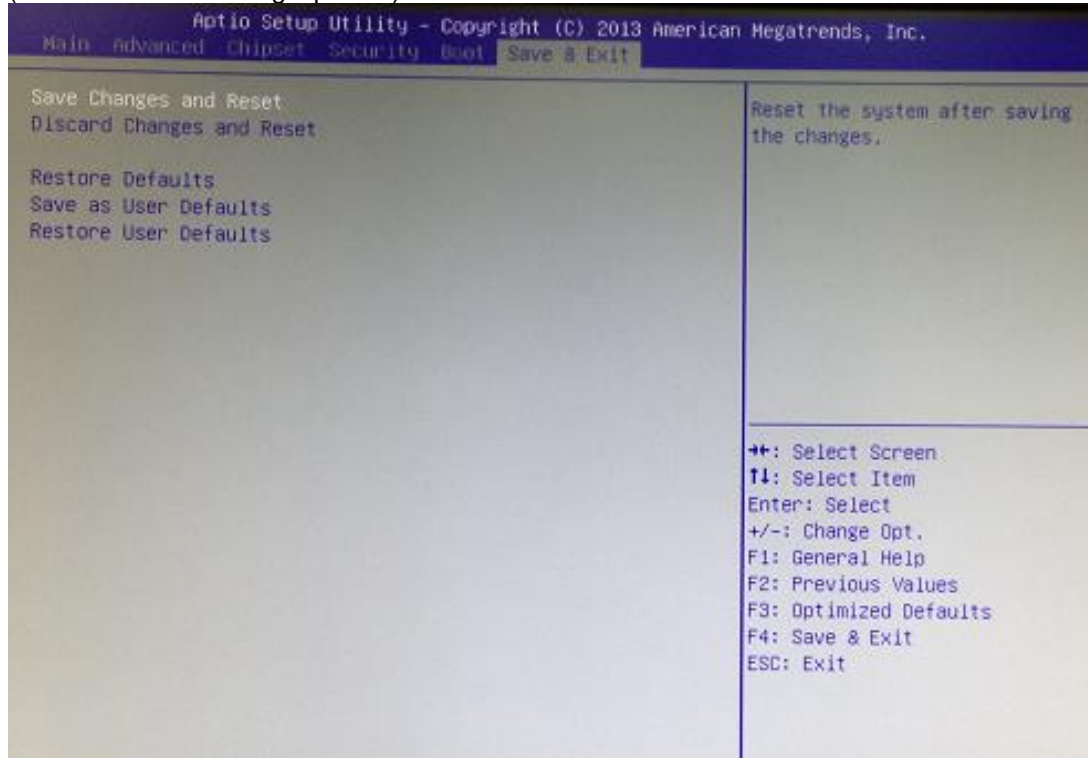

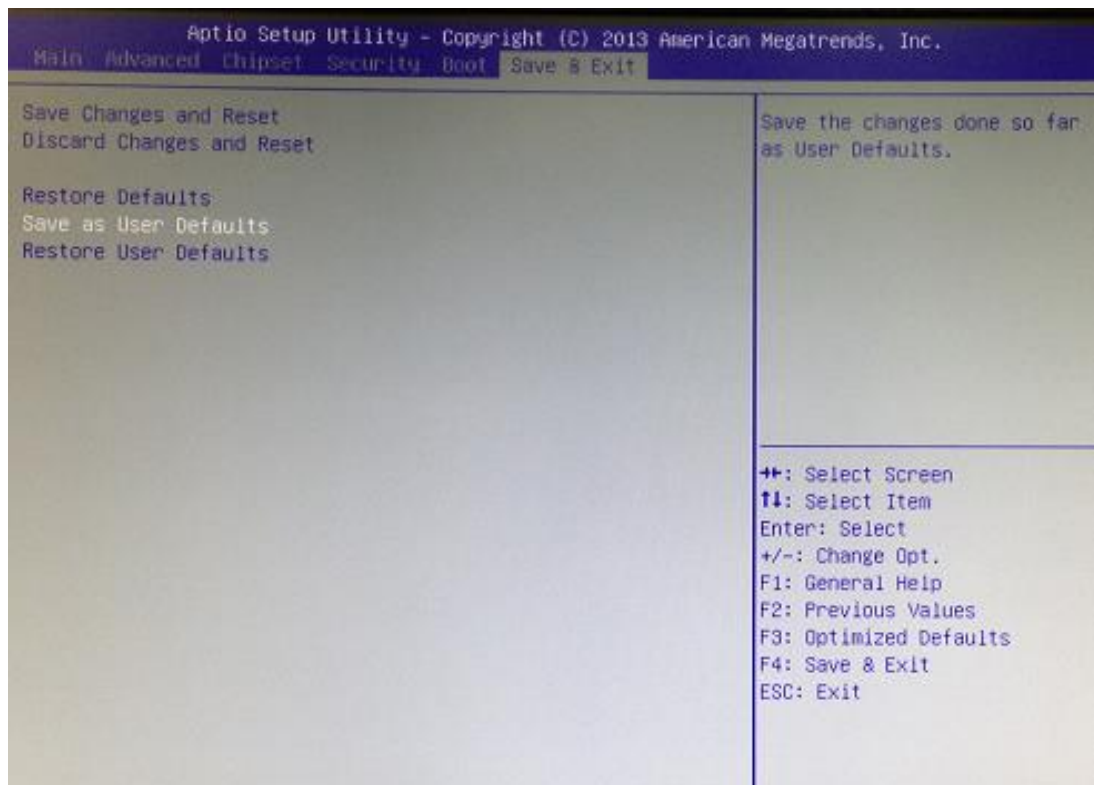
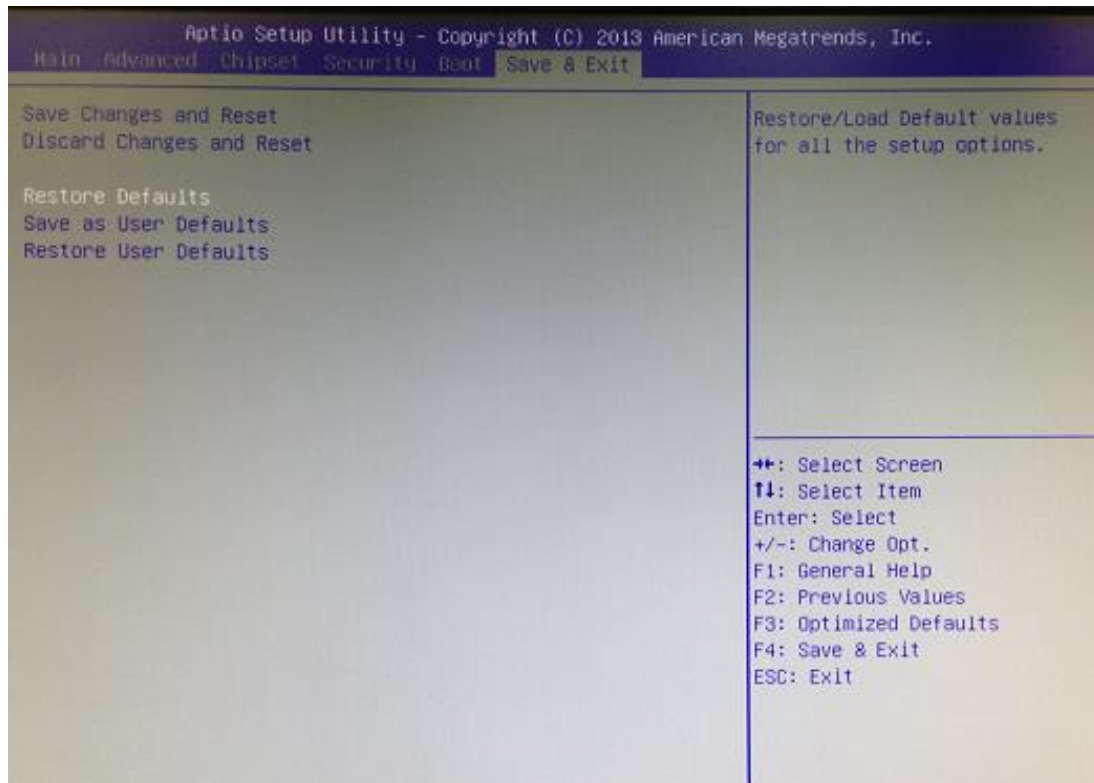

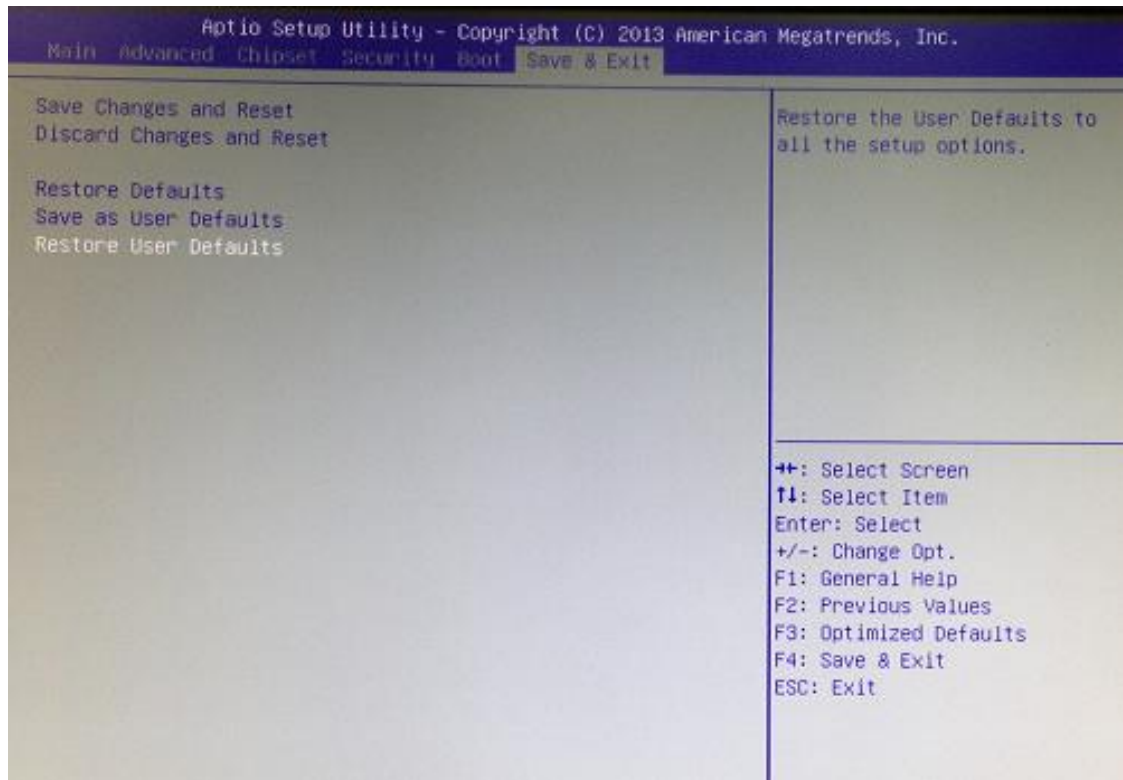

This page is intentionally left blank.

APPENDIX A WATCHDOG TIMER

About Watchdog Timer

After the system stops working for a while, it can be auto-reset by the watchdog timer. The integrated watchdog timer can be set up in the system reset mode by program.

How to Use Watchdog Timer

The following example enables configuration using debug tool.

Enable WDT

↓

Enable configuration:

O 2E 87 ; Un-lock super I/O

O 2E 87

↓

Select logic device:

O 2E 07

O 2F 08

↓

WDT device enable:

O 2E 30

O 2F 01

↓

Set timer unit:

O 2E F0

O 2F 00 ; (00: Sec; 08:Minute)

↓

Set base timer:

O 2E F1

O 2F 0A ; Set reset time (where 0A (hex) = 10sec)

Disable WDT



Enable configuration:

O 2E 87 ; Un-lock super I/O

O 2E 87



Select logic device:

O 2E 07

O 2F 08



WDT device disable:

O 2E 30

O 2F 00

APPENDIX B POWER BUTTON SETTING FOR WINDOW SOFTWARE

Please make the power button setting from the console of PC, then follow up below pictures to do the setting.

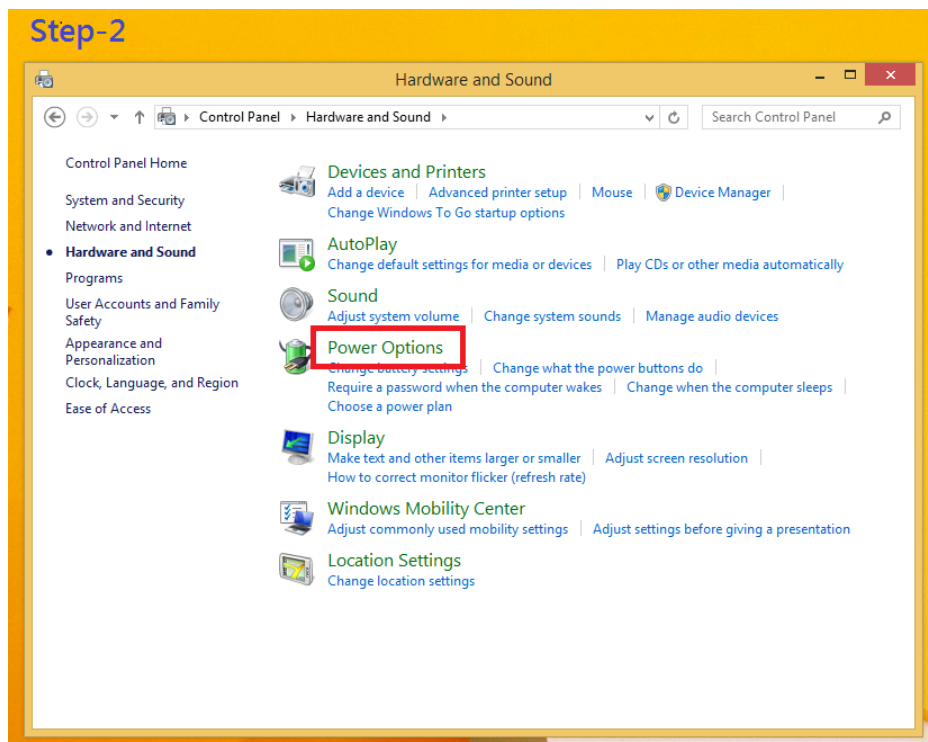
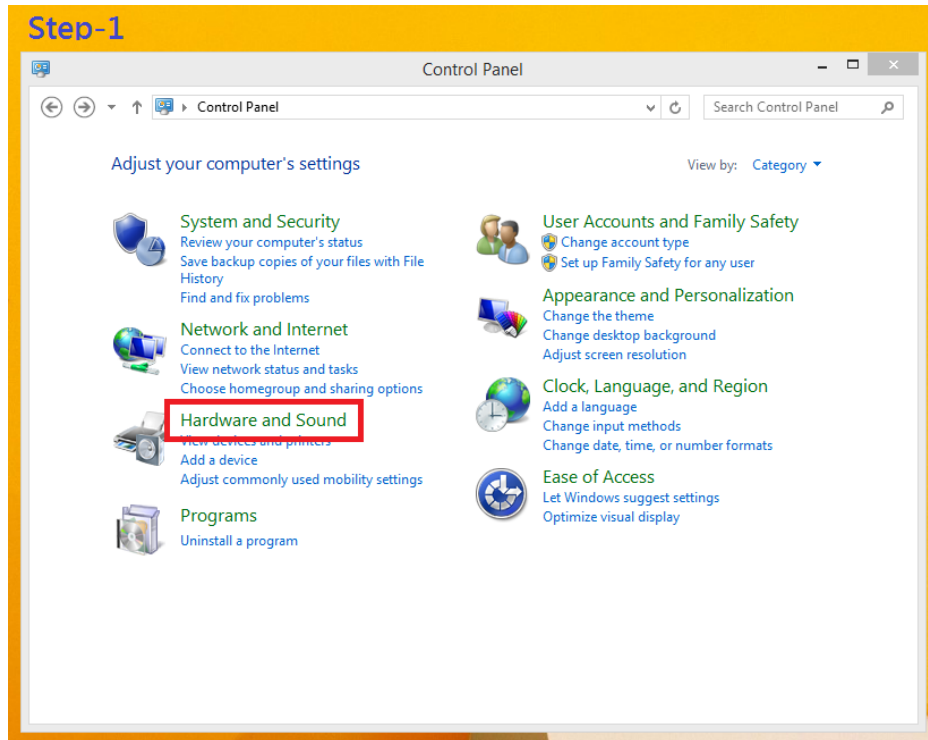

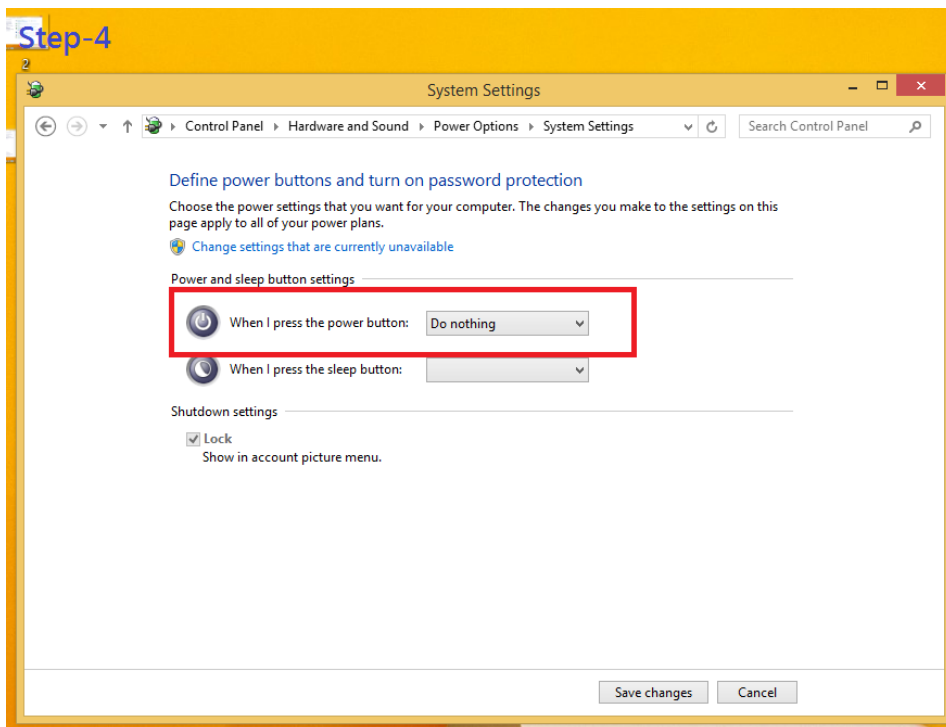
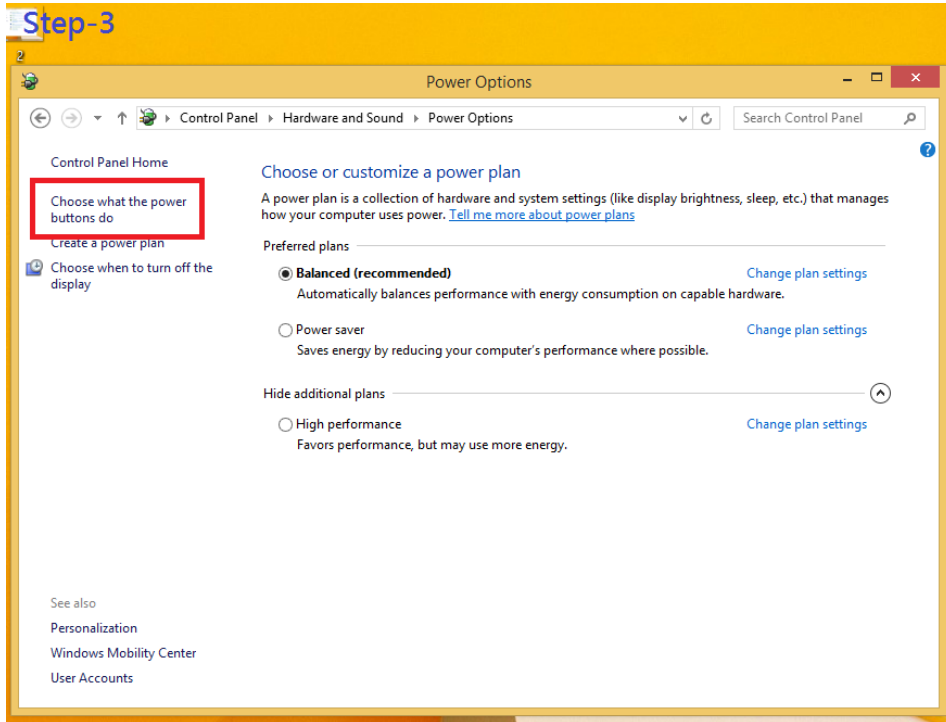

Step-5

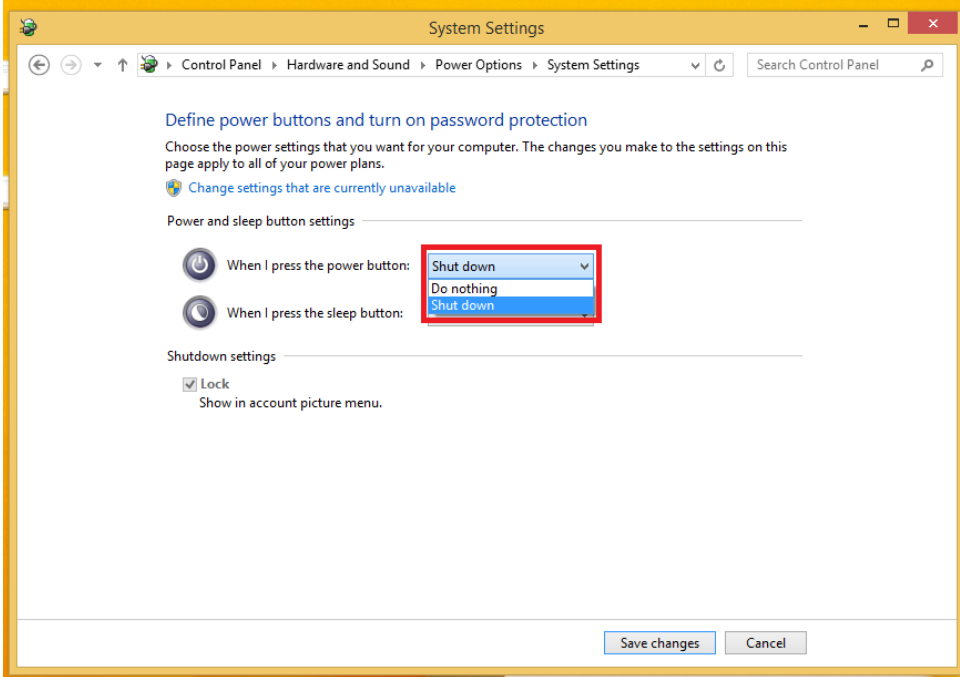

Step-6

