



AXIOMTEK

CEM130

**AMD Ryzen Embedded V1000
Processor COM Express™ Type 6
Compact Module**

User's Manual



Disclaimers

This manual has been carefully checked and believed to contain accurate information. Axiomtek Co., Ltd. assumes no responsibility for any infringements of patents or any third party's rights, and any liability arising from such use.

Axiomtek does not warrant or assume any legal liability or responsibility for the accuracy, completeness or usefulness of any information in this document. Axiomtek does not make any commitment to update the information in this manual.

Axiomtek reserves the right to change or revise this document and/or product at any time without notice.

No part of this document may be reproduced, stored in a retrieval system, or transmitted, in any form or by any means, electronic, mechanical, photocopying, recording, or otherwise, without the prior written permission of Axiomtek Co., Ltd.

CAUTION

If you replace wrong batteries, it causes the danger of explosion. It is recommended by the manufacturer that you follow the manufacturer's instructions to only replace the same or equivalent type of battery, and dispose of used ones.

©Copyright 2020 Axiomtek Co., Ltd.

All Rights Reserved

February 2020, Version A1

Printed in Taiwan

ESD Precautions

Computer boards have integrated circuits sensitive to static electricity. To prevent chipsets from electrostatic discharge damage, please take care of the following jobs with precautions:

- Do not remove modules or integrated circuits from their anti-static packaging until you are ready to install them.
- Before holding the module or integrated circuit, touch an unpainted portion of the system unit chassis for a few seconds. It discharges static electricity from your body.
- Wear a wrist-grounding strap, available from most electronic component stores, when handling modules and components.

Trademarks Acknowledgments

Axiomtek is a trademark of Axiomtek Co., Ltd.

Windows[®] is a trademark of Microsoft Corporation.

AMI is a trademark of American Megatrend Inc.

IBM, PC/AT, PS/2, VGA are trademarks of International Business Machines Corporation.

Intel[®], Celeron[®] are trademarks of Intel Corporation.

Other brand names and trademarks are the properties and registered brands of their respective owners.

Table of Contents

Disclaimers.....	ii
ESD Precautions.....	iii
Chapter 1 Introduction.....	1
1.1 Features	1
1.2 Specifications.....	2
1.3 Utilities Supported	3
1.4 Block Diagram	4
Chapter 2 Module and Pin Assignments.....	5
2.1 Module Dimensions and Fixing Holes.....	5
2.2 Module Layout.....	7
2.3 Installing Thermal Solution	9
2.4 Switch Settings	11
2.4.1 Auto Power On and Restore BIOS Optimal Defaults (SW1).....	11
2.5 Connectors	12
2.5.1 Fan Connector (CN1).....	12
2.5.2 COM Express™ Connectors (SSS1 and SSS2)	12
Chapter 3 Hardware Description	17
3.1 Microprocessor	17
3.2 BIOS	17
3.3 System Memory.....	17
3.4 I/O Port Address Map.....	18
3.5 Interrupt Controller (IRQ) Map	19
3.6 Memory Map	24
Chapter 4 AMI BIOS Setup Utility	25
4.1 Starting.....	25
4.2 Navigation Keys	25
4.3 Main Menu.....	27
4.4 Advanced Menu.....	28
4.5 Chipset Menu.....	40
4.6 Security Menu.....	45

4.7	Boot Menu.....	46
4.8	Save & Exit Menu	47
Appendix A Watchdog Timer and GPIO		49
A.1	About Watchdog Timer	49
A.2	How to Use Watchdog Timer	49
A.3	About GPIO.....	49
A.4	Sample Program.....	50

This page is intentionally left blank.

Chapter 1

Introduction

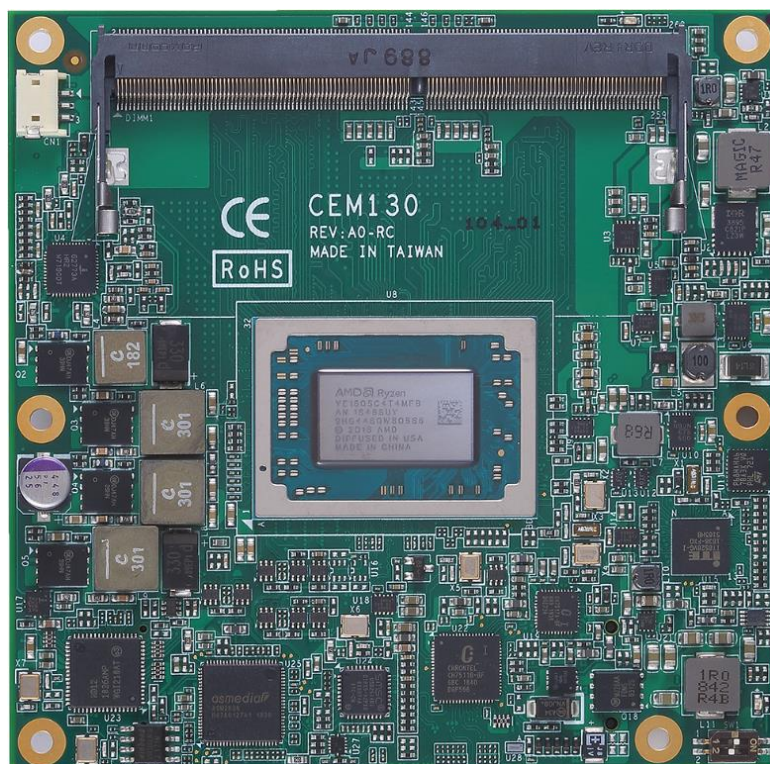

The CEM130 is a new COM Express™ Type 6 Compact Module powered by BGA type AMD Ryzen Embedded V1000 processor. The CEM130 fully complies with PICMG COM.0 Rev 3.0 COM Express™ Type 6 specification. In addition, it supports dual channel DDR-2400/3200 SO-DIMM up to 32GB and also provides maximum up to 7 lanes of PCI-Express, Gigabit Ethernet, HD audio interface, LVDS LCD and 2 configurable DDI for more flexible digital display options. The CEM130 also supports wide voltage input for various applications.

1.1 Features

- AMD Ryzen Embedded V1000 series
- 2 DDR-2400/3200 SO-DIMM for up to 32GB of memory (dual channel)
- Support 7 lanes of PCI-Express
- 2 SATA-600
- 3 USB 3.0 ports
- 8 USB 2.0 ports
- TPM v2.0
- Wide voltage input from -8 ~ +20V

1.2 Specifications

- **CPU**
 - V1202B / 2.3GHz (12-25W).
 - V1605B / 2.0GHz (12-25W).
 - V1756B / 3.25GHz (35-54W).
 - V1807B / 3.35GHz (35-54W).
- **BIOS**
 - American Megatrends Inc. BIOS.
 - UEFI Legacy Free.
- **System Memory**
 - Two 260-pin DDR4 2400/3200MHz SO-DIMM sockets for maximum memory capacity up to 32GB (memory speed depends on memory rank).
- **TPM**
 - Trusted Platform Module compatible with TPM2.0 Main and PC Client specification based on Intel LPC Bus Interface.
- **Expansion Interface**
 - Seven lanes of PCI-Express.
- **USB Interface**
 - Three USB ports comply with USB Spec. Rev. 3.0.
 - Eight USB ports comply with USB Spec. Rev. 2.0.
- **SATA Interface**
 - Two SATA 6Gb/s ports supported through COM Express™ connector.
- **Graphics & Display**
 - Vega GPU with up to 11 compute units.
 - H.265 (10-bit) decode & (8-bit) encode, VP9 decode.
 - 18/24-bit single/dual channel LVDS interface (eDP 1.3 optional).
 - VGA (1920x1200 @60Hz).
 - Two DDI ports support HDMI 1.4/DVI/DisplayPort 1.2.
(Note HDMI 2.0 needs redriver chip on carrier board / DP1.4 need redriver chip on carrier board).
- **Ethernet**
 - One 1000/100/10 Ethernet with Intel® i210; supports Wake-on-LAN, PXE Boot ROM.
- **Audio**
 - HD link interface to carrier board for codec.
- **General Purpose Serial Interface**
 - Support two UART interfaces.
- **Watchdog Timer**
 - Timeout value range is 0~65535 seconds.
- **Power Input**
 - ATX: +12V, +5VSB.
 - AT: +12V.
 - Wide range input : -8 ~ +20V.

- **Power Management**
 - ACPI (Advanced Configuration and Power Interface).
- **Operating Temperature Range**
 - -20°C to +60°C (-4°F to +140°F).
- **Form Factor**
 - Compact module 95mm x 95mm.

1.3 Utilities Supported

- Chipset driver
- Graphics driver
- Ethernet utility and driver
- ME driver



Note

All specifications and images are subject to change without notice.

1.4 Block Diagram

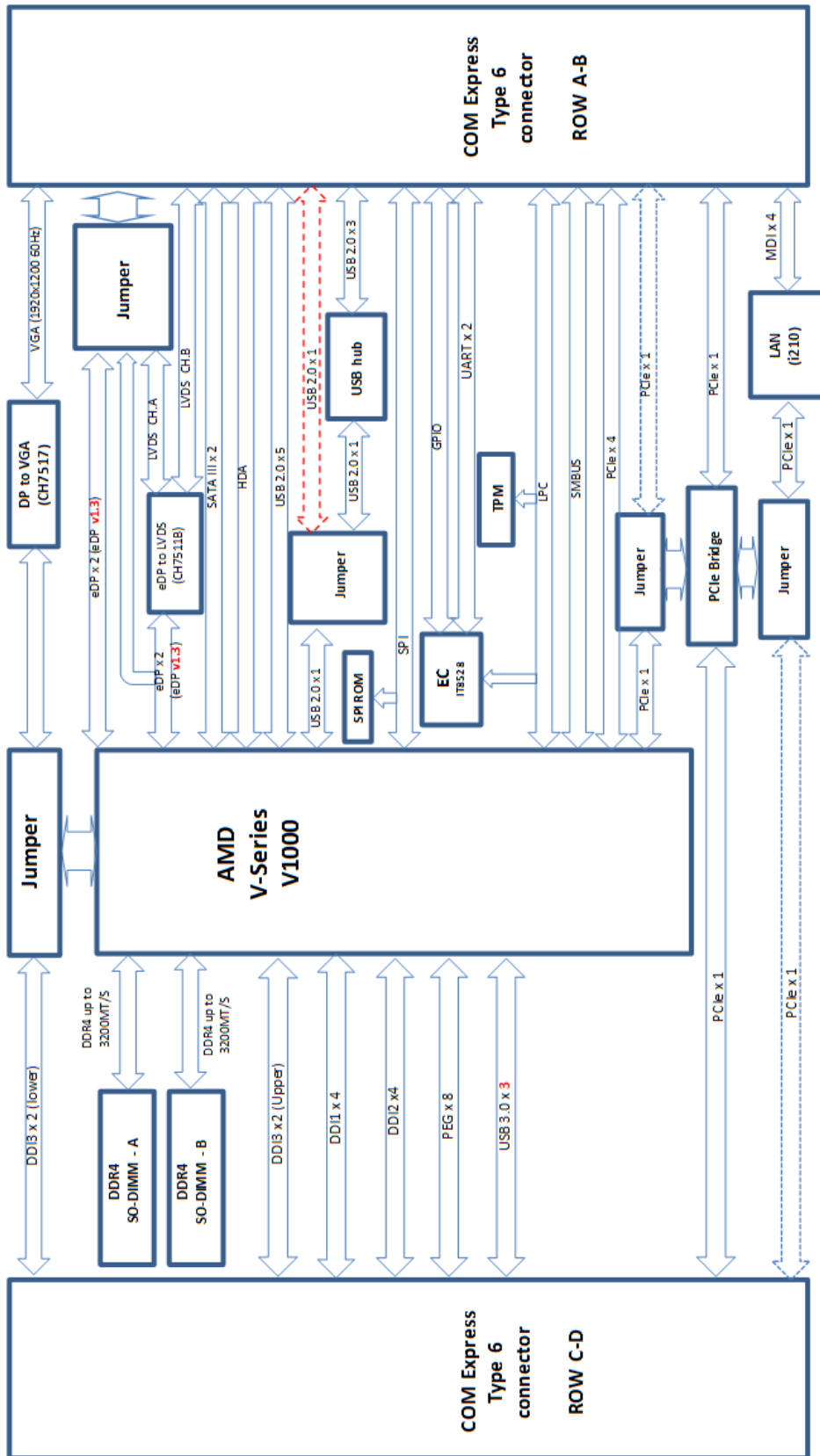

Chapter 2

Module and Pin Assignments

2.1 Module Dimensions and Fixing Holes

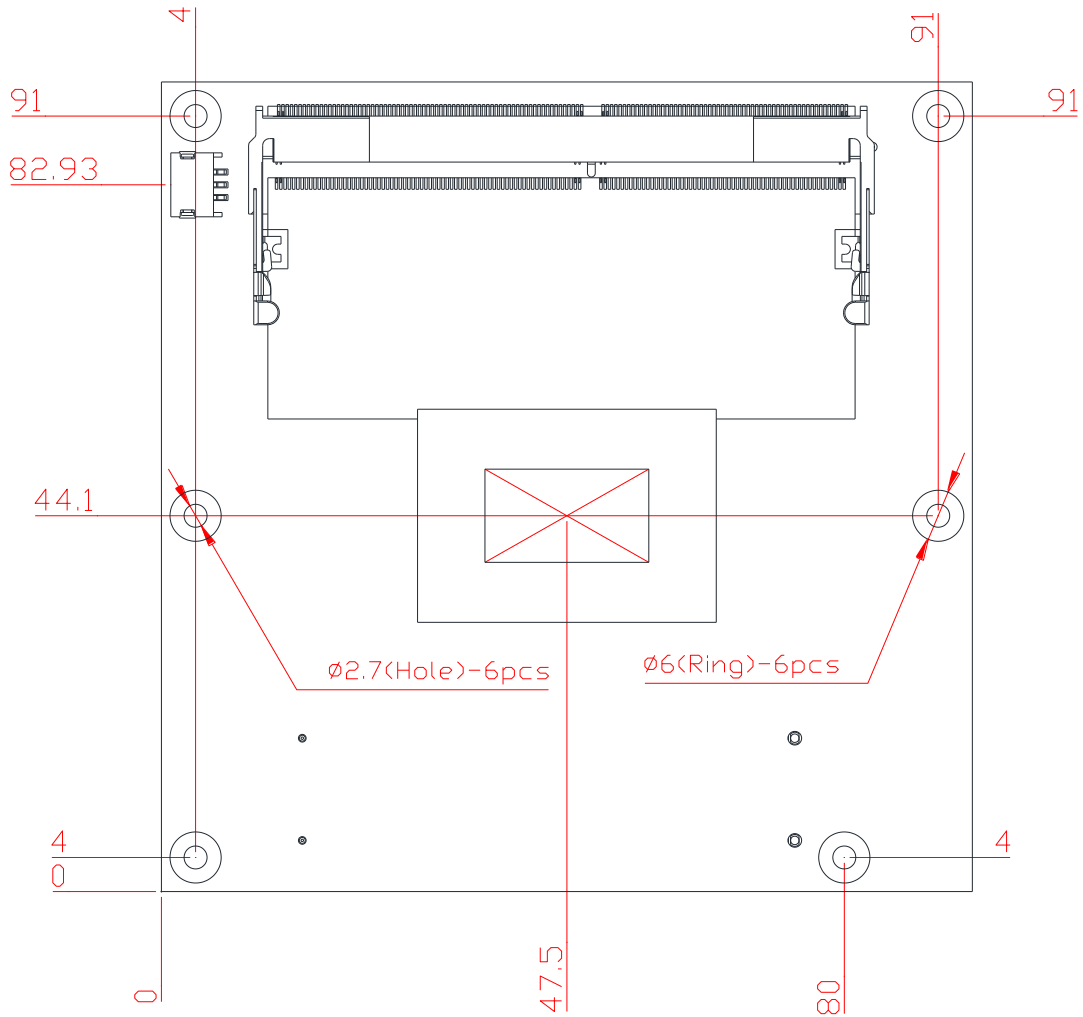

Top View

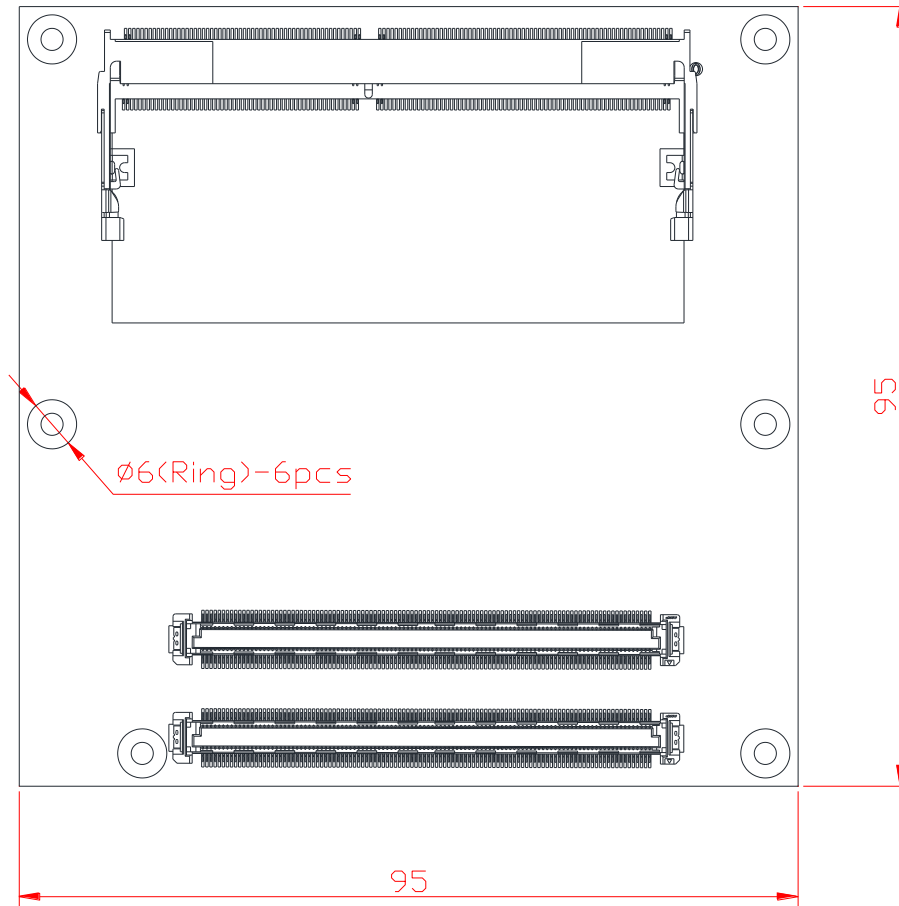

Bottom View

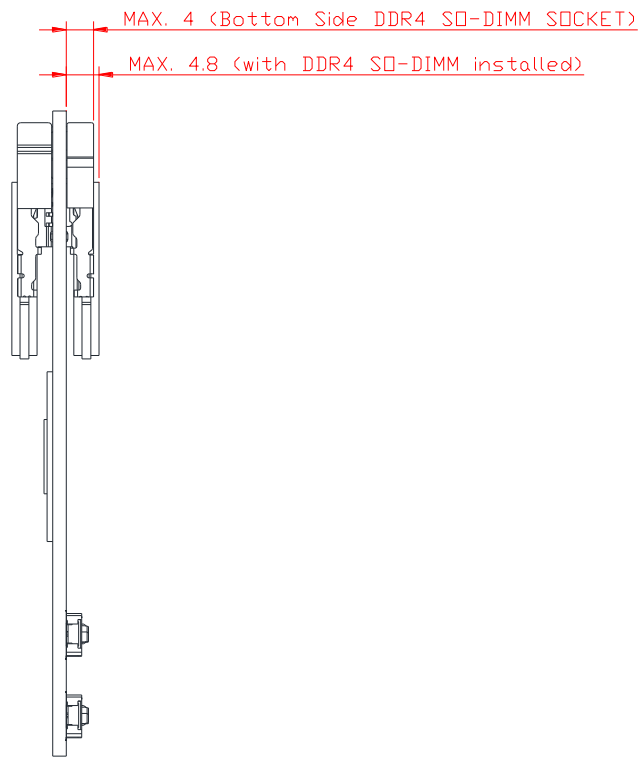

Side View



Note

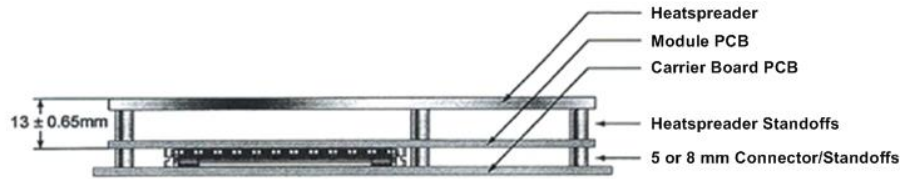

All dimensions in mm.

According to COM Express™ specification, the height of standoff between carrier board and module should be 5 or 8mm. When choosing or designing carrier board, especially when there are components on the carrier board in the area under the CEM130 module, please be reminded that maximum height of SO-DIMM socket placed on bottom side of CEM130 is 4.0mm. With SO-DIMM module installed, maximum height from module to CEM130 PCB bottom side would be 4.8mm.

2.2 Module Layout

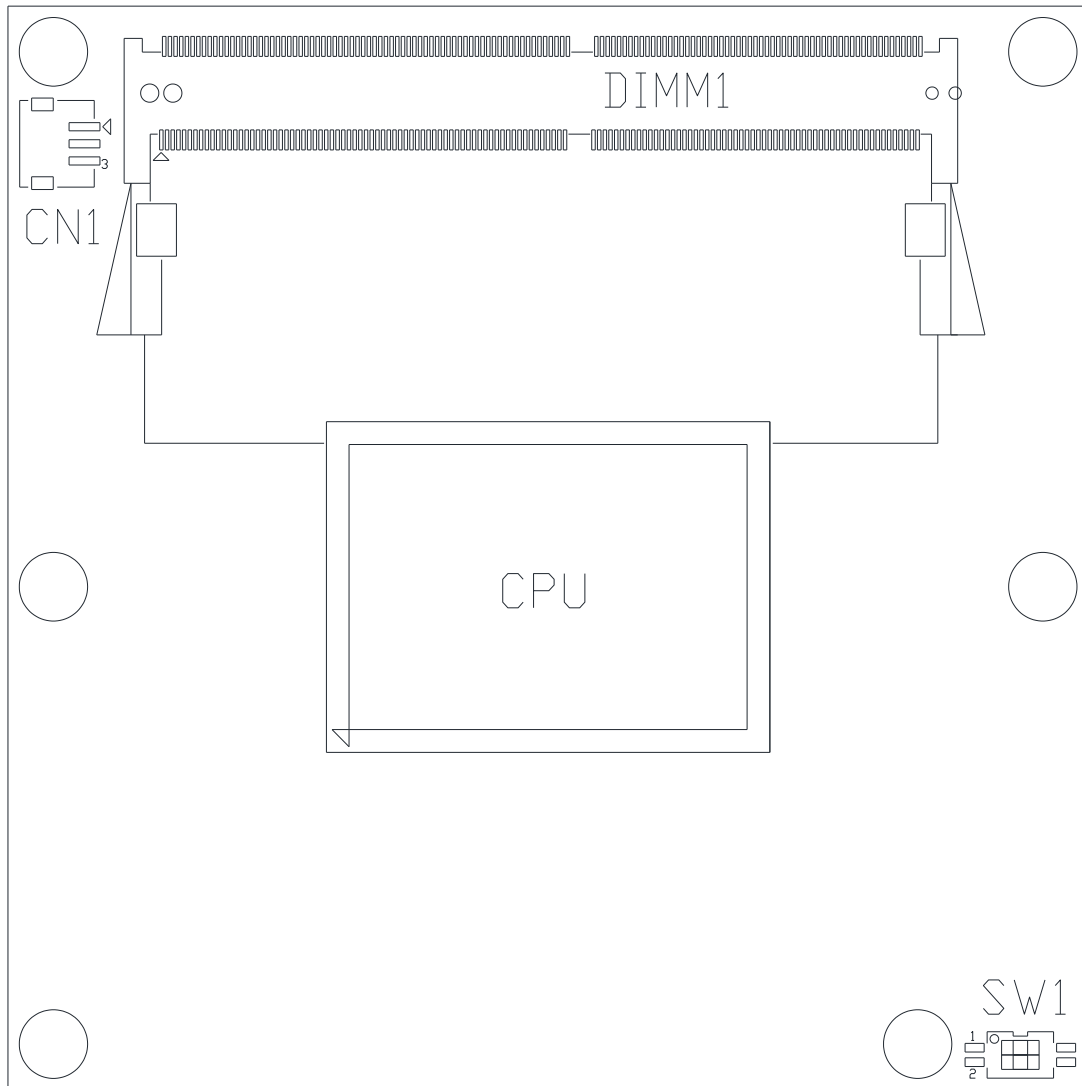

Top View

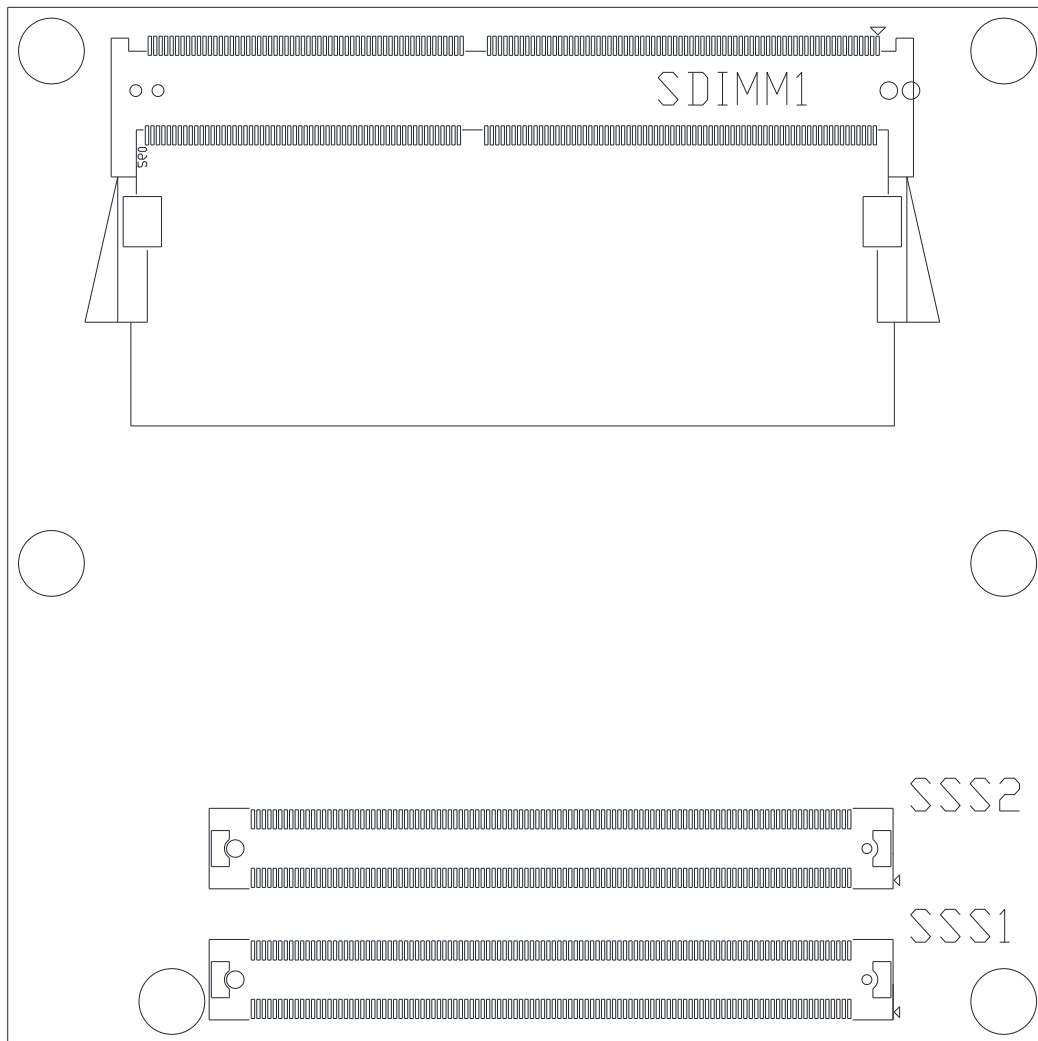

Bottom View

2.3 Installing Thermal Solution

For thermal dissipation, a thermal solution enables the CEM130's components to dissipate heat efficiently. All heat generating components are thermally conducted to the heatsink in order to avoid hot spots. Figure below illustrates how to install the thermal solution on CEM130.

1. There is a protective plastic covering on the thermal pads. This must be removed before the heatsink can be mounted.
2. Each heatsink is designed for a specific CEM module. The thermal pads on the heatsink are designed to make contact with the necessary components on the CEM module. When mounting the heatsink you must make sure that the thermal pads on the heatsink make complete contact (no space between thermal pad and component) with the corresponding components on the CEM module. This is especially critical for CEM modules that have higher CPU speeds (for example 1.46GHz or more) to ensure that the heatsink acts as a proper thermal interface for cooling solutions.
3. Before installing the heatsink to the CPU module, please apply thermal grease on the CPU die. This CPU module has assembly holes for installing heatsink plate. Use the appropriate screws to secure the heatsink plate to the CEM130. Be careful not to over-tighten the screws.

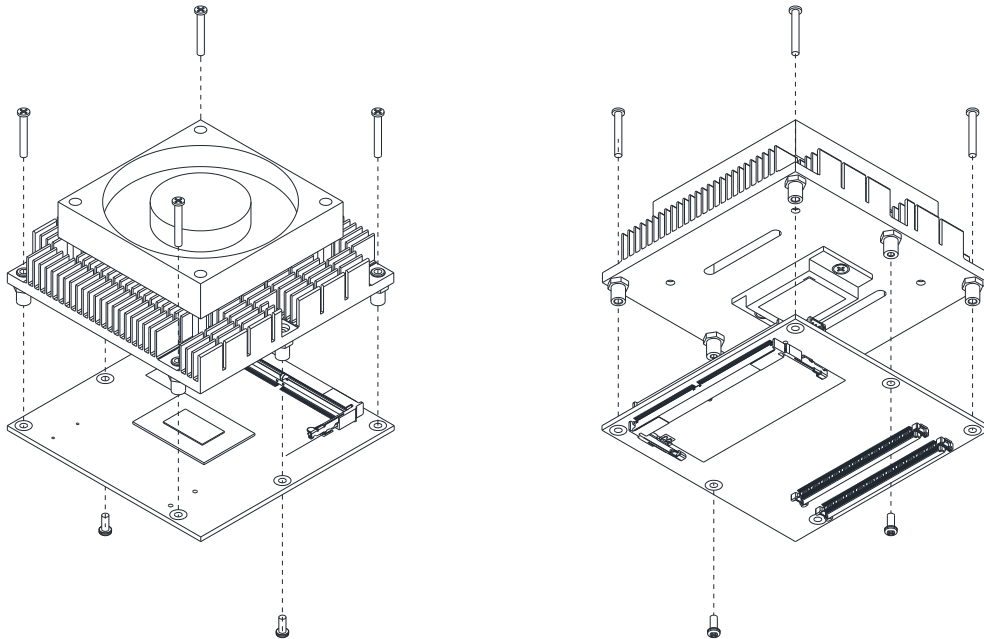



Note

When installing CEM130 on CEB94011, please add stand-off and secure with nut. Then, use the screws to secure the heatsink plate to the CEM130.

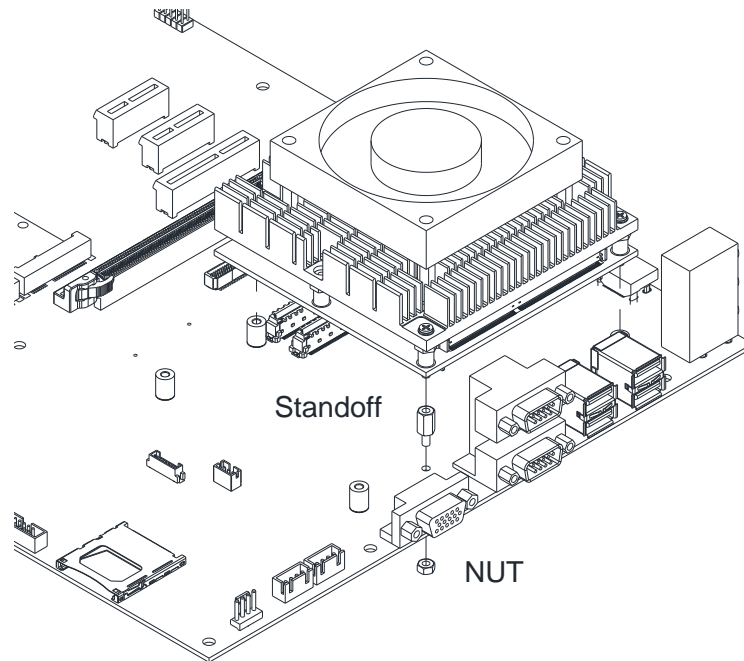

2.4 Switch Settings

Properly configure switch settings on the CEM130 to meet your application purpose. Below you can find a summary table of all switches and onboard default settings.



Note

Once the default switch setting needs to be changed, please do it under power-off condition.

Switch	Description	Setting
SW1	Auto Power On Default: Disable	SW1-1 OFF
	Restore BIOS Optimal Defaults Default: Normal Operation	SW1-2 OFF

2.4.1 Auto Power On and Restore BIOS Optimal Defaults (SW1)

If dip1 of SW1 (SW1-1) is set to ON position, the system will be automatically power on without pressing soft power button. If this switch is set to OFF position, it is necessary to manually press soft power button to power on the system.

The dip2 of SW1 (SW1-2) is for restoring BIOS default status. Flip SW1-2 to ON position for a few seconds then flip it back to OFF position. Doing this procedure can restore BIOS optimal defaults.

Function	Setting
Disable auto power on (Default)	SW1-1 OFF
Enable auto power on	SW1-1 ON
Normal operation (Default)	SW1-2 OFF
Restore BIOS optimal defaults	SW1-2 ON



2.5 Connectors

Signals go to the other parts of the system through connectors. Loose or improper connection might cause problems, please make sure all connectors are properly and firmly connected. Here is a summary table which shows connectors on the hardware.

Connector	Description
CN1	Fan Connector
SSS1	COM Express™ Connector
SSS2	COM Express™ Connector
SDIMM1	Channel 0 DDR4 SO-DIMM Socket
DIMM1	Channel 1 DDR4 SO-DIMM Socket



Note

- For single memory channel configuration, install memory module in channel 0 (SDIMM1) DDR4 SO-DIMM socket.
- For dual memory channel configuration, install memory modules of the same size, chip width, density and rank in channel 0 (SDIMM1) and channel 1 (DIMM1) DDR4 SO-DIMM sockets.

2.5.1 Fan Connector (CN1)

The CN1 is a 3-pin connector for fan interface.

Pin	Signal
1	GND
2	+12V level
3	Fan speed feedback

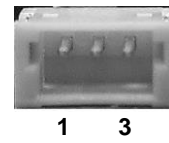
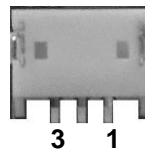

2.5.2 COM Express™ Connectors (SSS1 and SSS2)

The following table shows pin assignments of the 220-pin COM Express™ connectors.

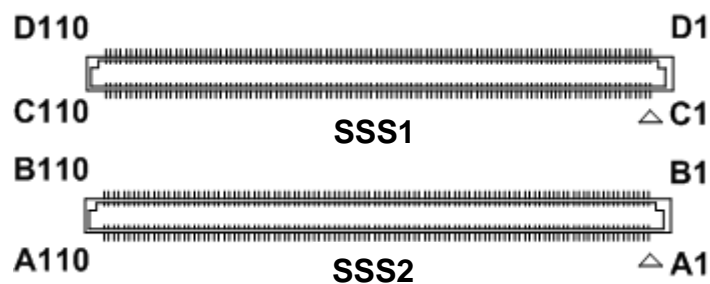

Pin	Signal	Pin	Signal	Pin	Signal	Pin	Signal
A1	GND (FIXED)	B1	GND (FIXED)	C1	GND (FIXED)	D1	GND (FIXED)
A2	GBE0_MDI3-	B2	GBE0_ACT#	C2	GND (FIXED)	D2	GND (FIXED)
A3	GBE0_MDI3+	B3	LPC_FRAME#/ ESPI_CS0#	C3	USB_SSRX0-	D3	USB_SSTX0-
A4	GBE0_LINK100#	B4	LPC_AD0/ ESPI_IO_0	C4	USB_SSRX0+	D4	USB_SSTX0+
A5	GBE0_LINK1000#	B5	LPC_AD1/ ESPI_IO_1	C5	GND (FIXED)	D5	GND (FIXED)
A6	GBE0_MDI2-	B6	LPC_AD2/ ESPI_IO_2	C6	USB_SSRX1-	D6	USB_SSTX1-
A7	GBE0_MDI2+	B7	LPC_AD3/ ESPI_IO_3	C7	USB_SSRX1+	D7	USB_SSTX1+
A8	GBE0_LINK#	B8	RSVD	C8	GND (FIXED)	D8	GND (FIXED)
A9	GBE0_MDI1-	B9	LPC_DRQ1#/ ESPI_ALERT1#	C9	USB_SSRX2-	D9	USB_SSTX2-
A10	GBE0_MDI1+	B10	LPC_CLK	C10	USB_SSRX2+	D10	USB_SSTX2+
A11	GND (FIXED)	B11	GND (FIXED)	C11	GND (FIXED)	D11	GND (FIXED)
A12	GBE0_MDI0-	B12	PWRBTN#	C12	USB_SSRX3-	D12	USB_SSTX3-
A13	GBE0_MDI0+	B13	SMB_CK	C13	USB_SSRX3+	D13	USB_SSTX3+
A14	GBE0_CTREF	B14	SMB_DAT	C14	GND (FIXED)	D14	GND (FIXED)
A15	SUS_S3#	B15	SMB_ALERT#	C15	DDI1_PAIR6+	D15	DDI1_CTRLCLK_AUX+
A16	SATA0_TX+	B16	SATA1_TX+	C16	DDI1_PAIR6-	D16	DDI1_CTRLDATA_AUX-
A17	SATA0_TX-	B17	SATA1_TX-	C17	RSVD	D17	RSVD
A18	SUS_S4#	B18	SUS_STAT#/ ESPI_RESET#	C18	RSVD	D18	RSVD
A19	SATA0_RX+	B19	SATA1_RX+	C19	PCIE_RX6+	D19	PCIE_TX6+
A20	SATA0_RX-	B20	SATA1_RX-	C20	PCIE_RX6-	D20	PCIE_TX6-
A21	GND (FIXED)	B21	GND (FIXED)	C21	GND (FIXED)	D21	GND (FIXED)
A22	SATA2_TX+	B22	SATA3_TX+	C22	PCIE_RX7+	D22	PCIE_TX7+
A23	SATA2_TX-	B23	SATA3_TX-	C23	PCIE_RX7-	D23	PCIE_TX7-
A24	SUS_S5#	B24	PWR_OK	C24	DDI1_HPD	D24	RSVD
A25	SATA2_RX+	B25	SATA3_RX+	C25	DDI1_PAIR4+	D25	RSVD
A26	SATA2_RX-	B26	SATA3_RX-	C26	DDI1_PAIR4-	D26	DDI1_PAIR0+
A27	BATLOW#	B27	WDT	C27	RSVD	D27	DDI1_PAIR0-
A28	(S)ATA_ACT#	B28	AC/HDA_SDIN2	C28	RSVD	D28	RSVD
A29	AC/HDA_SYNC	B29	AC/HDA_SDIN1	C29	DDI1_PAIR5+	D29	DDI1_PAIR1+
A30	AC/HDA_RST#	B30	AC/HDA_SDIN0	C30	DDI1_PAIR5-	D30	DDI1_PAIR1-
A31	GND (FIXED)	B31	GND (FIXED)	C31	GND (FIXED)	D31	GND (FIXED)
A32	AC/HDA_BITCLK	B32	SPKR	C32	DDI2_CTRLCLK_AUX+	D32	DDI1_PAIR2+
A33	AC/HDA_SDOOUT	B33	I2C_CK	C33	DDI2_CTRLDATA_AUX-	D33	DDI1_PAIR2-
A34	BIOS_DIS0#/ ESPI_SAFS	B34	I2C_DAT	C34	DDI2_DDC_AUX_SEL	D34	DDI1_DDC_AUX_SEL
A35	THRMTRIP#	B35	THRM#	C35	RSVD	D35	RSVD
A36	USB6-	B36	USB7-	C36	DDI3_CTRLCLK_AUX+	D36	DDI1_PAIR3+
A37	USB6+	B37	USB7+	C37	DDI3_CTRLDATA_AUX-	D37	DDI1_PAIR3-
A38	USB_6_7_OC#	B38	USB_4_5_OC#	C38	DDI3_DDC_AUX_SEL	D38	RSVD
A39	USB4-	B39	USB5-	C39	DDI3_PAIR0+	D39	DDI2_PAIR0+
A40	USB4+	B40	USB5+	C40	DDI3_PAIR0-	D40	DDI2_PAIR0-
A41	GND (FIXED)	B41	GND (FIXED)	C41	GND (FIXED)	D41	GND (FIXED)
A42	USB2-	B42	USB3-	C42	DDI3_PAIR1+	D42	DDI2_PAIR1+
A43	USB2+	B43	USB3+	C43	DDI3_PAIR1-	D43	DDI2_PAIR1-
A44	USB_2_3_OC#	B44	USB_0_1_OC#	C44	DDI3_HPD	D44	DDI2_HPD
A45	USB0-	B45	USB1-	C45	RSVD	D45	RSVD
A46	USB0+	B46	USB1+	C46	DDI3_PAIR2+	D46	DDI2_PAIR2+
A47	VCC_RTC	B47	ESPI_EN#	C47	DDI3_PAIR2-	D47	DDI2_PAIR2-
A48	RSVD	B48	USB0_HOST_PRSN	C48	RSVD	D48	RSVD
A49	GBE0_SDP	B49	SYS_RESET#	C49	DDI3_PAIR3+	D49	DDI2_PAIR3+

Pin	Signal	Pin	Signal	Pin	Signal	Pin	Signal
A50	LPC_SERIRQ/ ESPI_CS1#	B50	CB_RESET#	C50	DDI3_PAIR3-	D50	DDI2_PAIR3-
A51	GND (FIXED)	B51	GND (FIXED)	C51	GND (FIXED)	D51	GND (FIXED)
A52	PCIE_TX5+	B52	PCIE_RX5+	C52	PEG_RX0+	D52	PEG_TX0+
A53	PCIE_TX5-	B53	PCIE_RX5-	C53	PEG_RX0-	D53	PEG_TX0-
A54	GPI0	B54	GPO1	C54	TYPE0#	D54	PEG_LANE_RV#
A55	PCIE_TX4+	B55	PCIE_RX4+	C55	PEG_RX1+	D55	PEG_TX1+
A56	PCIE_TX4-	B56	PCIE_RX4-	C56	PEG_RX1-	D56	PEG_TX1-
A57	GND	B57	GPO2	C57	TYPE1#	D57	TYPE2#
A58	PCIE_TX3+	B58	PCIE_RX3+	C58	PEG_RX2+	D58	PEG_TX2+
A59	PCIE_TX3-	B59	PCIE_RX3-	C59	PEG_RX2-	D59	PEG_TX2-
A60	GND (FIXED)	B60	GND (FIXED)	C60	GND (FIXED)	D60	GND (FIXED)
A61	PCIE_TX2+	B61	PCIE_RX2+	C61	PEG_RX3+	D61	PEG_TX3+
A62	PCIE_TX2-	B62	PCIE_RX2-	C62	PEG_RX3-	D62	PEG_TX3-
A63	GPI1	B63	GPO3	C63	RSVD	D63	RSVD
A64	PCIE_TX1+	B64	PCIE_RX1+	C64	RSVD	D64	RSVD
A65	PCIE_TX1-	B65	PCIE_RX1-	C65	PEG_RX4+	D65	PEG_TX4+
A66	GND	B66	WAKE0#	C66	PEG_RX4-	D66	PEG_TX4-
A67	GPI2	B67	WAKE1#	C67	RAPID_SHUTDOWN	D67	GND
A68	PCIE_TX0+	B68	PCIE_RX0+	C68	PEG_RX5+	D68	PEG_TX5+
A69	PCIE_TX0-	B69	PCIE_RX0-	C69	PEG_RX5-	D69	PEG_TX5-
A70	GND(FIXED)	B70	GND(FIXED)	C70	GND(FIXED)	D70	GND(FIXED)
A71	LVDS_A0+	B71	LVDS_B0+	C71	PEG_RX6+	D71	PEG_TX6+
A72	LVDS_A0-	B72	LVDS_B0-	C72	PEG_RX6-	D72	PEG_TX6-
A73	LVDS_A1+	B73	LVDS_B1+	C73	GND(FIXED)	D73	SDVO_CLK
A74	LVDS_A1-	B74	LVDS_B1-	C74	PEG_RX7+	D74	PEG_TX7+
A75	LVDS_A2+	B75	LVDS_B2+	C75	PEG_RX7-	D75	PEG_TX7-
A76	LVDS_A2-	B76	LVDS_B2-	C76	GND	D76	GND
A77	LVDS_VDD_EN	B77	LVDS_B3+	C77	RSVD	D77	RSVD
A78	LVDS_A3+	B78	LVDS_B3-	C78	PEG_RX8+	D78	PEG_TX8+
A79	LVDS_A3-	B79	LVDS_BKLT_EN	C79	PEG_RX8-	D79	PEG_TX8-
A80	GND(FIXED)	B80	GND(FIXED)	C80	GND(FIXED)	D80	GND(FIXED)
A81	LVDS_A_CK+	B81	LVDS_B_CK+	C81	PEG_RX9+	D81	PEG_TX9+
A82	LVDS_A_CK-	B82	LVDS_B_CK-	C82	PEG_RX9-	D82	PEG_TX9-
A83	LVDS_I2C_CK	B83	LVDS_BKLT_CTRL	C83	RSVD	D83	RSVD
A84	LVDS_I2C_DAT	B84	VCC_5V_SBY	C84	GND	D84	GND
A85	GPI3	B85	VCC_5V_SBY	C85	PEG_RX10+	D85	PEG_TX10+
A86	RSVD	B86	VCC_5V_SBY	C86	PEG_RX10-	D86	PEG_TX10-
A87	eDP_HPDP	B87	VCC_5V_SBY	C87	GND	D87	GND
A88	PCIE0_CK_REF+	B88	BIOS_DIS1	C88	PEG_RX11+	D88	PEG_TX11+
A89	PCIE0_CK_REF-	B89	VGA_RED	C89	PEG_RX11-	D89	PEG_TX11-
A90	GND (FIXED)	B90	GND (FIXED)	C90	GND (FIXED)	D90	GND (FIXED)
A91	SPI_POWER	B91	VGA_GRN	C91	PEG_RX12+	D91	PEG_TX12+
A92	SPI_MISO	B92	VGA_BLU	C92	PEG_RX12-	D92	PEG_TX12-
A93	GPO0	B93	VGA_HSYNC	C93	GND	D93	GND
A94	SPI_CLK	B94	VGA_VSYNC	C94	PEG_RX13+	D94	PEG_TX13+
A95	SPI_MOSI	B95	VGA_I2C_CK	C95	PEG_RX13-	D95	PEG_TX13-
A96	TPM_PP	B96	VGA_I2C_DAT	C96	GND	D96	GND
A97	TYPE10#	B97	SPI_CS#	C97	RSVD	D97	RSVD
A98	SER0_TX	B98	RSVD	C98	PEG_RX14+	D98	PEG_TX14+
A99	SER0_RX	B99	RSVD	C99	PEG_RX14-	D99	PEG_TX14-
A100	GND (FIXED)	B100	GND (FIXED)	C100	GND (FIXED)	D100	GND (FIXED)
A101	SER1_TX	B101	FAN_PWMOUT	C101	PEG_RX15+	D101	PEG_TX15+
A102	SER1_RX	B102	FAN_TACHIN	C102	PEG_RX15-	D102	PEG_TX15-
A103	LID#	B103	SLEEP#	C103	GND	D103	GND
A104	VCC_12V	B104	VCC_12V	C104	VCC_12V	D104	VCC_12V

Pin	Signal	Pin	Signal	Pin	Signal	Pin	Signal
A105	VCC_12V	B105	VCC_12V	C105	VCC_12V	D105	VCC_12V
A106	VCC_12V	B106	VCC_12V	C106	VCC_12V	D106	VCC_12V
A107	VCC_12V	B107	VCC_12V	C107	VCC_12V	D107	VCC_12V
A108	VCC_12V	B108	VCC_12V	C108	VCC_12V	D108	VCC_12V
A109	VCC_12V	B109	VCC_12V	C109	VCC_12V	D109	VCC_12V
A110	GND (FIXED)	B110	GND (FIXED)	C110	GND (FIXED)	D110	GND (FIXED)

This page is intentionally left blank.

Chapter 3

Hardware Description

3.1 Microprocessor

The CEM130 supports AMD Ryzen Embedded V1000 processor which enable your system to operate under Windows® 10, and Linux environments. The system performance depends on the microprocessor. You must install the thermal solution or cooler carefully and properly to prevent damage.

3.2 BIOS

The CEM130 uses AMI Plug and Play BIOS with a single 64Mbit SPI Flash.

3.3 System Memory

The CEM130 supports two 260-pin DDR4 SO-DIMM sockets for maximum memory capacity up to 32GB. The memory module comes in sizes of 1GB, 2GB, 4GB, or 8GB.







































































































3.4 I/O Port Address Map











































The I/O port addresses are as follows:

- Input/output (IO)
 - [0000000000000000 - 0000000000003AF] PCI Express Root Complex
 - [0000000000000000 - 00000000000000F] Direct memory access controller
 - [0000000000000010 - 00000000000001F] Motherboard resources
 - [0000000000000020 - 000000000000021F] Programmable interrupt controller
 - [0000000000000022 - 000000000000003F] Motherboard resources
 - [0000000000000040 - 0000000000000043] System timer
 - [0000000000000061 - 0000000000000061F] System speaker
 - [0000000000000063 - 0000000000000063F] Motherboard resources
 - [0000000000000065 - 0000000000000065F] Motherboard resources
 - [0000000000000067 - 0000000000000067F] Motherboard resources
 - [0000000000000070 - 0000000000000071F] System CMOS/real time clock
 - [0000000000000072 - 0000000000000072F] Motherboard resources
 - [0000000000000080 - 0000000000000080F] Motherboard resources
 - [0000000000000081 - 0000000000000083F] Direct memory access controller
 - [0000000000000084 - 0000000000000086F] Motherboard resources
 - [0000000000000087 - 0000000000000087F] Direct memory access controller
 - [0000000000000088 - 0000000000000088F] Motherboard resources
 - [0000000000000089 - 0000000000000089F] Direct memory access controller
 - [000000000000008C - 000000000000008EF] Motherboard resources
 - [000000000000008F - 000000000000008FF] Direct memory access controller
 - [0000000000000090 - 0000000000000090F] Motherboard resources
 - [00000000000000A0 - 00000000000000A1F] Programmable interrupt controller
 - [00000000000000A2 - 00000000000000B0F] Motherboard resources
 - [00000000000000B1 - 00000000000000B1F] Motherboard resources
 - [00000000000000C0 - 00000000000000DF] Direct memory access controller
 - [00000000000000E0 - 00000000000000E0F] Motherboard resources
 - [0000000000000248 - 0000000000000248F] Communications Port (COM1)
 - [0000000000000268 - 0000000000000268F] Communications Port (COM2)
 - [00000000000002F8 - 00000000000002FF] Communications Port (COM2)
 - [00000000000003B0 - 00000000000003DF] PCI Express Root Complex
 - [00000000000003B0 - 00000000000003BBF] PCI Express Root Port
 - [00000000000003B0 - 00000000000003BB] AMD Radeon(TM) Vega 11 Graphics
 - [00000000000003C0 - 00000000000003DF] PCI Express Root Port
 - [00000000000003C0 - 00000000000003DF] AMD Radeon(TM) Vega 11 Graphics
 - [00000000000003E0 - 0000000000000CF7] PCI Express Root Complex
 - [00000000000003F8 - 00000000000003FF] Communications Port (COM1)
 - [000000000000040B - 000000000000040BF] Motherboard resources
 - [00000000000004D0 - 00000000000004D1F] Motherboard resources
 - [00000000000004D6 - 00000000000004D6F] Motherboard resources
 - [0000000000000800 - 000000000000089F] Motherboard resources
 - [0000000000000900 - 000000000000090F] Motherboard resources
 - [0000000000000910 - 000000000000091F] Motherboard resources
 - [0000000000000A00 - 0000000000000A0F] Motherboard resources
 - [0000000000000A10 - 0000000000000A1F] Motherboard resources
 - [0000000000000A20 - 0000000000000A2F] Motherboard resources
 - [0000000000000B00 - 0000000000000B0F] Motherboard resources
 - [0000000000000B20 - 0000000000000B3F] Motherboard resources
 - [0000000000000C00 - 0000000000000C01F] Motherboard resources
 - [0000000000000C14 - 0000000000000C14F] Motherboard resources
 - [0000000000000C50 - 0000000000000C51F] Motherboard resources
 - [0000000000000C52 - 0000000000000C52F] Motherboard resources
 - [0000000000000C6C - 0000000000000C6CF] Motherboard resources
 - [0000000000000C6F - 0000000000000C6FF] Motherboard resources
 - [0000000000000CD0 - 0000000000000CD1F] Motherboard resources
 - [0000000000000CD2 - 0000000000000CD3F] Motherboard resources
 - [0000000000000CD4 - 0000000000000CD5F] Motherboard resources
 - [0000000000000CD6 - 0000000000000CD7F] Motherboard resources
 - [0000000000000CD8 - 0000000000000CDF] Motherboard resources
 - [0000000000000D00 - 0000000000000EFFF] PCI Express Root Complex
 - [0000000000000B00 - 0000000000000B0FF] AMD Radeon(TM) Vega 8 Graphics
 - [0000000000000C00 - 0000000000000CFFF] PCI Express Root Port
 - [0000000000000D00 - 0000000000000DFFF] PCI Express Root Port
 - [0000000000000D00 - 0000000000000DFFF] PCI Express Root Port
 - [0000000000000D00 - 0000000000000D0FF] AMD Radeon(TM) Vega 11 Graphics
 - [0000000000000E00 - 0000000000000EFFF] PCI Express Root Port
 - [0000000000000E00 - 0000000000000EFFF] PCI Express Upstream Switch Port
 - [0000000000000F00 - 0000000000000FFF] PCI Express Root Port

3.5 Interrupt Controller (IRQ) Map

The interrupt controller (IRQ) mapping list is shown as follows:

▼  Interrupt request (IRQ)	
 (ISA) 0x00000000 (00) High precision event timer	 (ISA) 0x00000061 (97) Microsoft ACPI-Compliant System
 (ISA) 0x00000000 (00) System timer	 (ISA) 0x00000062 (98) Microsoft ACPI-Compliant System
 (ISA) 0x00000003 (03) Communications Port (COM2)	 (ISA) 0x00000063 (99) Microsoft ACPI-Compliant System
 (ISA) 0x00000004 (04) Communications Port (COM1)	 (ISA) 0x00000064 (100) Microsoft ACPI-Compliant System
 (ISA) 0x00000007 (07) AMD GPIO Controller	 (ISA) 0x00000065 (101) Microsoft ACPI-Compliant System
 (ISA) 0x00000008 (08) High precision event timer	 (ISA) 0x00000066 (102) Microsoft ACPI-Compliant System
 (ISA) 0x0000000A (10) Communications Port (COM2)	 (ISA) 0x00000067 (103) Microsoft ACPI-Compliant System
 (ISA) 0x0000000B (11) AMD Radeon(TM) Vega 8 Graphics	 (ISA) 0x00000068 (104) Microsoft ACPI-Compliant System
 (ISA) 0x0000000B (11) Communications Port (COM1)	 (ISA) 0x00000069 (105) Microsoft ACPI-Compliant System
 (ISA) 0x00000037 (55) Microsoft ACPI-Compliant System	 (ISA) 0x0000006A (106) Microsoft ACPI-Compliant System
 (ISA) 0x00000038 (56) Microsoft ACPI-Compliant System	 (ISA) 0x0000006B (107) Microsoft ACPI-Compliant System
 (ISA) 0x00000039 (57) Microsoft ACPI-Compliant System	 (ISA) 0x0000006C (108) Microsoft ACPI-Compliant System
 (ISA) 0x0000003A (58) Microsoft ACPI-Compliant System	 (ISA) 0x0000006D (109) Microsoft ACPI-Compliant System
 (ISA) 0x0000003B (59) Microsoft ACPI-Compliant System	 (ISA) 0x0000006E (110) Microsoft ACPI-Compliant System
 (ISA) 0x0000003C (60) Microsoft ACPI-Compliant System	 (ISA) 0x0000006F (111) Microsoft ACPI-Compliant System
 (ISA) 0x0000003D (61) Microsoft ACPI-Compliant System	 (ISA) 0x00000070 (112) Microsoft ACPI-Compliant System
 (ISA) 0x0000003E (62) Microsoft ACPI-Compliant System	 (ISA) 0x00000071 (113) Microsoft ACPI-Compliant System
 (ISA) 0x0000003F (63) Microsoft ACPI-Compliant System	 (ISA) 0x00000072 (114) Microsoft ACPI-Compliant System
 (ISA) 0x00000040 (64) Microsoft ACPI-Compliant System	 (ISA) 0x00000073 (115) Microsoft ACPI-Compliant System
 (ISA) 0x00000041 (65) Microsoft ACPI-Compliant System	 (ISA) 0x00000074 (116) Microsoft ACPI-Compliant System
 (ISA) 0x00000042 (66) Microsoft ACPI-Compliant System	 (ISA) 0x00000075 (117) Microsoft ACPI-Compliant System
 (ISA) 0x00000043 (67) Microsoft ACPI-Compliant System	 (ISA) 0x00000076 (118) Microsoft ACPI-Compliant System
 (ISA) 0x00000044 (68) Microsoft ACPI-Compliant System	 (ISA) 0x00000077 (119) Microsoft ACPI-Compliant System
 (ISA) 0x00000045 (69) Microsoft ACPI-Compliant System	 (ISA) 0x00000078 (120) Microsoft ACPI-Compliant System
 (ISA) 0x00000046 (70) Microsoft ACPI-Compliant System	 (ISA) 0x00000079 (121) Microsoft ACPI-Compliant System
 (ISA) 0x00000047 (71) Microsoft ACPI-Compliant System	 (ISA) 0x0000007A (122) Microsoft ACPI-Compliant System
 (ISA) 0x00000048 (72) Microsoft ACPI-Compliant System	 (ISA) 0x0000007B (123) Microsoft ACPI-Compliant System
 (ISA) 0x00000049 (73) Microsoft ACPI-Compliant System	 (ISA) 0x0000007C (124) Microsoft ACPI-Compliant System
 (ISA) 0x0000004A (74) Microsoft ACPI-Compliant System	 (ISA) 0x0000007D (125) Microsoft ACPI-Compliant System
 (ISA) 0x0000004B (75) Microsoft ACPI-Compliant System	 (ISA) 0x0000007E (126) Microsoft ACPI-Compliant System
 (ISA) 0x0000004C (76) Microsoft ACPI-Compliant System	 (ISA) 0x0000007F (127) Microsoft ACPI-Compliant System
 (ISA) 0x0000004D (77) Microsoft ACPI-Compliant System	 (ISA) 0x00000080 (128) Microsoft ACPI-Compliant System
 (ISA) 0x0000004E (78) Microsoft ACPI-Compliant System	 (ISA) 0x00000081 (129) Microsoft ACPI-Compliant System
 (ISA) 0x0000004F (79) Microsoft ACPI-Compliant System	 (ISA) 0x00000082 (130) Microsoft ACPI-Compliant System
 (ISA) 0x00000050 (80) Microsoft ACPI-Compliant System	 (ISA) 0x00000083 (131) Microsoft ACPI-Compliant System
 (ISA) 0x00000051 (81) Microsoft ACPI-Compliant System	 (ISA) 0x00000084 (132) Microsoft ACPI-Compliant System
 (ISA) 0x00000052 (82) Microsoft ACPI-Compliant System	 (ISA) 0x00000085 (133) Microsoft ACPI-Compliant System
 (ISA) 0x00000053 (83) Microsoft ACPI-Compliant System	 (ISA) 0x00000086 (134) Microsoft ACPI-Compliant System
 (ISA) 0x00000054 (84) Microsoft ACPI-Compliant System	 (ISA) 0x00000087 (135) Microsoft ACPI-Compliant System
 (ISA) 0x00000055 (85) Microsoft ACPI-Compliant System	 (ISA) 0x00000088 (136) Microsoft ACPI-Compliant System
 (ISA) 0x00000056 (86) Microsoft ACPI-Compliant System	 (ISA) 0x00000089 (137) Microsoft ACPI-Compliant System
 (ISA) 0x00000057 (87) Microsoft ACPI-Compliant System	 (ISA) 0x0000008A (138) Microsoft ACPI-Compliant System
 (ISA) 0x00000058 (88) Microsoft ACPI-Compliant System	 (ISA) 0x0000008B (139) Microsoft ACPI-Compliant System
 (ISA) 0x00000059 (89) Microsoft ACPI-Compliant System	 (ISA) 0x0000008C (140) Microsoft ACPI-Compliant System
 (ISA) 0x0000005A (90) Microsoft ACPI-Compliant System	 (ISA) 0x0000008D (141) Microsoft ACPI-Compliant System
 (ISA) 0x0000005B (91) Microsoft ACPI-Compliant System	 (ISA) 0x0000008E (142) Microsoft ACPI-Compliant System
 (ISA) 0x0000005C (92) Microsoft ACPI-Compliant System	 (ISA) 0x0000008F (143) Microsoft ACPI-Compliant System
 (ISA) 0x0000005D (93) Microsoft ACPI-Compliant System	 (ISA) 0x00000090 (144) Microsoft ACPI-Compliant System
 (ISA) 0x0000005E (94) Microsoft ACPI-Compliant System	 (ISA) 0x00000091 (145) Microsoft ACPI-Compliant System
 (ISA) 0x0000005F (95) Microsoft ACPI-Compliant System	 (ISA) 0x00000092 (146) Microsoft ACPI-Compliant System
 (ISA) 0x00000060 (96) Microsoft ACPI-Compliant System	 (ISA) 0x00000093 (147) Microsoft ACPI-Compliant System

	(ISA) 0x000001F9 (505)	Microsoft ACPI-Compliant System
	(ISA) 0x000001FA (506)	Microsoft ACPI-Compliant System
	(ISA) 0x000001FB (507)	Microsoft ACPI-Compliant System
	(ISA) 0x000001FC (508)	Microsoft ACPI-Compliant System
	(ISA) 0x000001FD (509)	Microsoft ACPI-Compliant System
	(ISA) 0x000001FE (510)	Microsoft ACPI-Compliant System
	(ISA) 0x000001FF (511)	Microsoft ACPI-Compliant System
	(PCI) 0x00000035 (53)	AMD Audio CoProcessor
	(PCI) 0x00000035 (53)	High Definition Audio Controller
	(PCI) 0x00000036 (54)	High Definition Audio Controller
	(PCI) 0x00000037 (55)	AMD SFH KMDf I2C
	(PCI) 0xFFFFFE0 (-32)	Intel(R) I210 Gigabit Network Connection
	(PCI) 0xFFFFFE1 (-31)	Intel(R) I210 Gigabit Network Connection
	(PCI) 0xFFFFFE2 (-30)	Intel(R) I210 Gigabit Network Connection
	(PCI) 0xFFFFFE3 (-29)	Intel(R) I210 Gigabit Network Connection
	(PCI) 0xFFFFFE4 (-28)	Intel(R) I210 Gigabit Network Connection
	(PCI) 0xFFFFFE5 (-27)	Intel(R) I210 Gigabit Network Connection
	(PCI) 0xFFFFFE6 (-26)	AMD USB 3.10 eXtensible Host Controller - 1.10 (Microsoft)
	(PCI) 0xFFFFFE7 (-25)	AMD USB 3.10 eXtensible Host Controller - 1.10 (Microsoft)
	(PCI) 0xFFFFFE8 (-24)	AMD USB 3.10 eXtensible Host Controller - 1.10 (Microsoft)
	(PCI) 0xFFFFFE9 (-23)	AMD USB 3.10 eXtensible Host Controller - 1.10 (Microsoft)
	(PCI) 0xFFFFFEA (-22)	AMD USB 3.10 eXtensible Host Controller - 1.10 (Microsoft)
	(PCI) 0xFFFFFEB (-21)	AMD USB 3.10 eXtensible Host Controller - 1.10 (Microsoft)
	(PCI) 0xFFFFFEC (-20)	AMD USB 3.10 eXtensible Host Controller - 1.10 (Microsoft)
	(PCI) 0xFFFFFED (-19)	AMD USB 3.10 eXtensible Host Controller - 1.10 (Microsoft)
	(PCI) 0xFFFFFEE (-18)	AMD USB 3.10 eXtensible Host Controller - 1.10 (Microsoft)
	(PCI) 0xFFFFFEF (-17)	AMD USB 3.10 eXtensible Host Controller - 1.10 (Microsoft)
	(PCI) 0xFFFFF00 (-16)	AMD USB 3.10 eXtensible Host Controller - 1.10 (Microsoft)
	(PCI) 0xFFFFF01 (-15)	AMD USB 3.10 eXtensible Host Controller - 1.10 (Microsoft)
	(PCI) 0xFFFFF02 (-14)	AMD USB 3.10 eXtensible Host Controller - 1.10 (Microsoft)
	(PCI) 0xFFFFF03 (-13)	AMD USB 3.10 eXtensible Host Controller - 1.10 (Microsoft)
	(PCI) 0xFFFFF04 (-12)	AMD USB 3.10 eXtensible Host Controller - 1.10 (Microsoft)
	(PCI) 0xFFFFF05 (-11)	AMD USB 3.10 eXtensible Host Controller - 1.10 (Microsoft)
	(PCI) 0xFFFFF06 (-10)	AMD Radeon(TM) Vega 11 Graphics
	(PCI) 0xFFFFF07 (-9)	AMD Radeon(TM) Vega 11 Graphics
	(PCI) 0xFFFFF08 (-8)	AMD Radeon(TM) Vega 11 Graphics
	(PCI) 0xFFFFF09 (-7)	AMD PSP 10.0 Device
	(PCI) 0xFFFFF0A (-6)	AMD PSP 10.0 Device
	(PCI) 0xFFFFF0B (-5)	Standard SATA AHCI Controller
	(PCI) 0xFFFFF0C (-4)	PCI Express Root Port
	(PCI) 0xFFFFF0D (-3)	PCI Express Root Port
	(PCI) 0xFFFFF0E (-2)	PCI Express Root Port

3.6 Memory Map

The memory mapping list is shown as follows:

- Memory
 - [0000000000A0000 - 0000000000BFFFF] PCI Express Root Complex
 - [0000000000A0000 - 0000000000BFFFF] PCI Express Root Port
 - [0000000000A0000 - 0000000000BFFFF] AMD Radeon(TM) Vega 11 Graphics
 - [0000000000C0000 - 0000000000DFFFF] PCI Express Root Complex
 - [00000000E0000000 - 00000000FEBFFFF] PCI Express Root Complex
 - [00000000E0000000 - 00000000F01FFFF] PCI Express Root Port
 - [00000000E0000000 - 00000000EFFFFFF] AMD Radeon(TM) Vega 11 Graphics
 - [00000000E0000000 - 00000000EFFFFFF] AMD Radeon(TM) Vega 8 Graphics
 - [00000000F0000000 - 00000000F01FFFF] AMD Radeon(TM) Vega 11 Graphics
 - [00000000F0000000 - 00000000F01FFFF] AMD Radeon(TM) Vega 8 Graphics
 - [00000000F0300000 - 00000000F03FFFF] PCI Express Root Port
 - [00000000F0400000 - 00000000F04FFFF] PCI Express Root Port
 - [00000000F0500000 - 00000000F05FFFF] PCI Express Root Port
 - [00000000F0600000 - 00000000F06FFFF] PCI Express Root Port
 - [00000000F8000000 - 00000000FBFFFF] System board
 - [00000000FD100000 - 00000000FDFFFF] Motherboard resources
 - [00000000FE400000 - 00000000FE8FFFF] PCI Express Root Port
 - [00000000FE400000 - 00000000FE4FFFF] AMD SFH KMDf I2C
 - [00000000FE500000 - 00000000FE5FFFF] AMD USB 3.10 eXtensible Host Controller - 1.10 (Microsoft)
 - [00000000FE500000 - 00000000FE57FFF] AMD Radeon(TM) Vega 8 Graphics
 - [00000000FE600000 - 00000000FE6FFFF] AMD USB 3.10 eXtensible Host Controller - 1.10 (Microsoft)
 - [00000000FE700000 - 00000000FE7FFFF] AMD PSP 10.0 Device
 - [00000000FE700000 - 00000000FE7FFFF] PCI Express Root Port
 - [00000000FE800000 - 00000000FE8FFFF] PCI Express Root Port
 - [00000000FE800000 - 00000000FE87FFF] AMD Radeon(TM) Vega 11 Graphics
 - [00000000FE880000 - 00000000FE8BFFF] AMD Audio CoProcessor
 - [00000000FE8C0000 - 00000000FE8C7FFF] High Definition Audio Controller
 - [00000000FE8C8000 - 00000000FE8CBFFF] High Definition Audio Controller
 - [00000000FE8CC000 - 00000000FE8CDFFF] AMD SFH KMDf I2C
 - [00000000FE8CE000 - 00000000FE8CFFFF] AMD PSP 10.0 Device
 - [00000000FE900000 - 00000000FE9FFFF] PCI Express Root Port
 - [00000000FE900000 - 00000000FE99FFF] PCI Express Root Port
 - [00000000FE900000 - 00000000FE907FF] Standard SATA AHCI Controller
 - [00000000FEA00000 - 00000000FEAFFFF] PCI Express Root Port
 - [00000000FEA00000 - 00000000FEAFFFF] PCI Express Upstream Switch Port
 - [00000000FEA00000 - 00000000FEAFFFF] PCI Express Downstream Switch Port
 - [00000000FEA00000 - 00000000FEAFFFF] PCI Express Root Port
 - [00000000FEA7C000 - 00000000FEA7FFF] Intel(R) I210 Gigabit Network Connection
 - [00000000FEA80000 - 00000000FEAFFFF] Intel(R) I210 Gigabit Network Connection
 - [00000000FEC00000 - 00000000FEC0FFF] Motherboard resources
 - [00000000FEC01000 - 00000000FEC01FFF] Motherboard resources
 - [00000000FEC10000 - 00000000FEC10FFF] Motherboard resources
 - [00000000FED00000 - 00000000FED003FF] High precision event timer
 - [00000000FED40000 - 00000000FED44FFF] Trusted Platform Module 2.0
- [00000000FED80000 - 00000000FED8FFFF] Motherboard resources
 - [00000000FED81500 - 00000000FED818FF] AMD GPIO Controller
- [00000000FEDC0000 - 00000000FEDC0FFF] Motherboard resources
- [00000000FEE00000 - 00000000FFFFFF] PCI Express Root Complex
 - [00000000FEE00000 - 00000000FEE00FFF] Motherboard resources
 - [00000000FF000000 - 00000000FFFFFF] Motherboard resources

Chapter 4

AMI BIOS Setup Utility

The AMI UEFI BIOS provides users with a built-in setup program to modify basic system configuration. All configured parameters are stored in a flash chip to save the setup information whenever the power is turned off. This chapter provides users with detailed description about how to set up basic system configuration through the AMI BIOS setup utility.

4.1 Starting

To enter the setup screens, follow the steps below:

1. Turn on the computer and press the key immediately.
2. After you press the key, the main BIOS setup menu displays. You can access the other setup screens from the main BIOS setup menu, such as the Advanced and Chipset menus.



Note

If your computer cannot boot after making and saving system changes with BIOS setup, you can restore BIOS optimal defaults by setting SW1-2 (see section 2.4.1).

It is strongly recommended that you should avoid changing the chipset's defaults. Both AMI and your system manufacturer have carefully set up these defaults that provide the best performance and reliability.

4.2 Navigation Keys

The BIOS setup/utility uses a key-based navigation system called hot keys. Most of the BIOS setup utility hot keys can be used at any time during the setup navigation process. These keys include <F1>, <F2>, <Enter>, <ESC>, <Arrow> keys, and so on.



Note

Some of the navigation keys differ from one screen to another.

Hot Keys	Description
→← Left/Right	The Left and Right <Arrow> keys allow you to select a setup screen.
↑↓ Up/Down	The Up and Down <Arrow> keys allow you to select a setup screen or sub-screen.
+– Plus/Minus	The Plus and Minus <Arrow> keys allow you to change the field value of a particular setup item.
Tab	The <Tab> key allows you to select setup fields.
F1	The <F1> key allows you to display the General Help screen.
F2	The <F2> key allows you to Load Previous Values.
F3	The <F3> key allows you to Load Optimized Defaults.
F4	The <F4> key allows you to save any changes you have made and exit Setup. Press the <F4> key to save your changes.
Esc	The <Esc> key allows you to discard any changes you have made and exit the Setup. Press the <Esc> key to exit the setup without saving your changes.
Enter	The <Enter> key allows you to display or change the setup option listed for a particular setup item. The <Enter> key can also allow you to display the setup sub- screens.

4.3 Main Menu

When you first enter the setup utility, you will enter the Main setup screen. You can always return to the Main setup screen by selecting the Main tab. System Time/Date can be set up as described below. The Main BIOS setup screen is shown below.

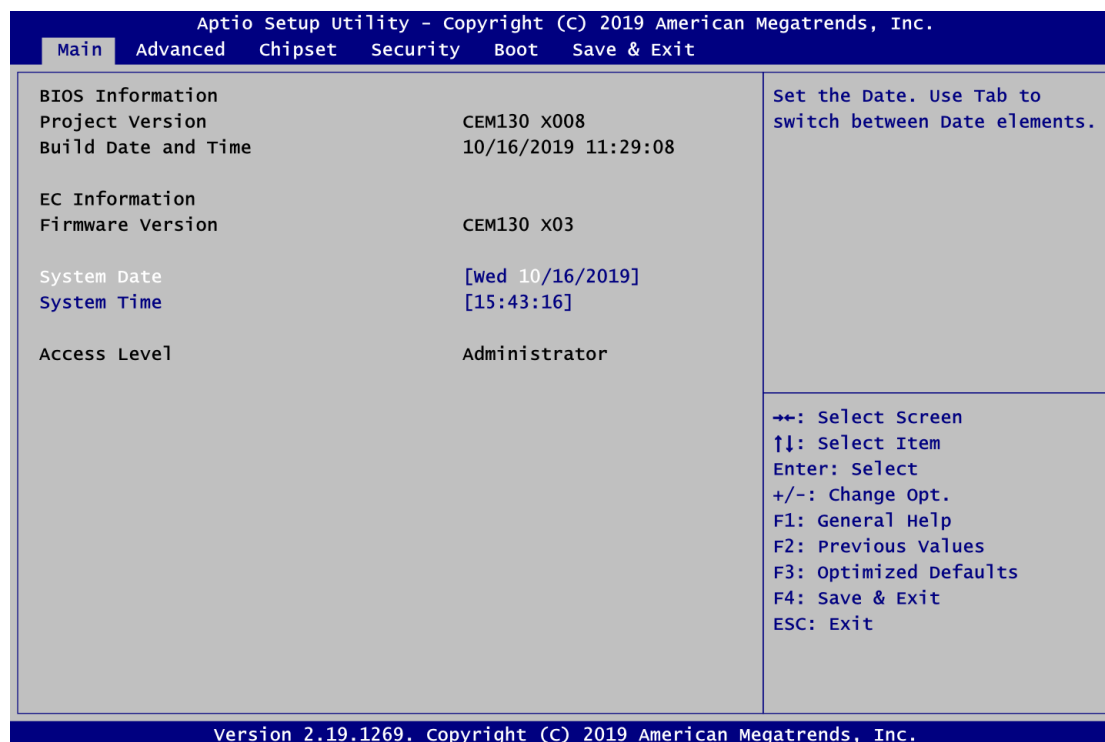

BIOS Information

Display BIOS and EC firmware information.

System Date/Time

Use this option to change the system time and date. Highlight System Time or System Date using the <Arrow> keys. Enter new values through the keyboard. Press the <Tab> key or the <Arrow> keys to move between fields. The date must be entered in MM/DD/YY format. The time is entered in HH:MM:SS format.

Access Level

Display the access level of current user.

4.4 Advanced Menu

The Advanced menu also allows users to set configuration of the CPU and other system devices. You can select any of the items in the left frame of the screen to go to the sub menus:

- ▶ EC DIO Configuration
- ▶ Serial Port Configuration
- ▶ Hardware Monitor
- ▶ ACPI Settings
- ▶ Trusted Computing
- ▶ CPU Configuration
- ▶ SATA Configuration
- ▶ USB Configuration
- ▶ Serial Port Console Redirection

For items marked with “▶”, please press <Enter> for more options.

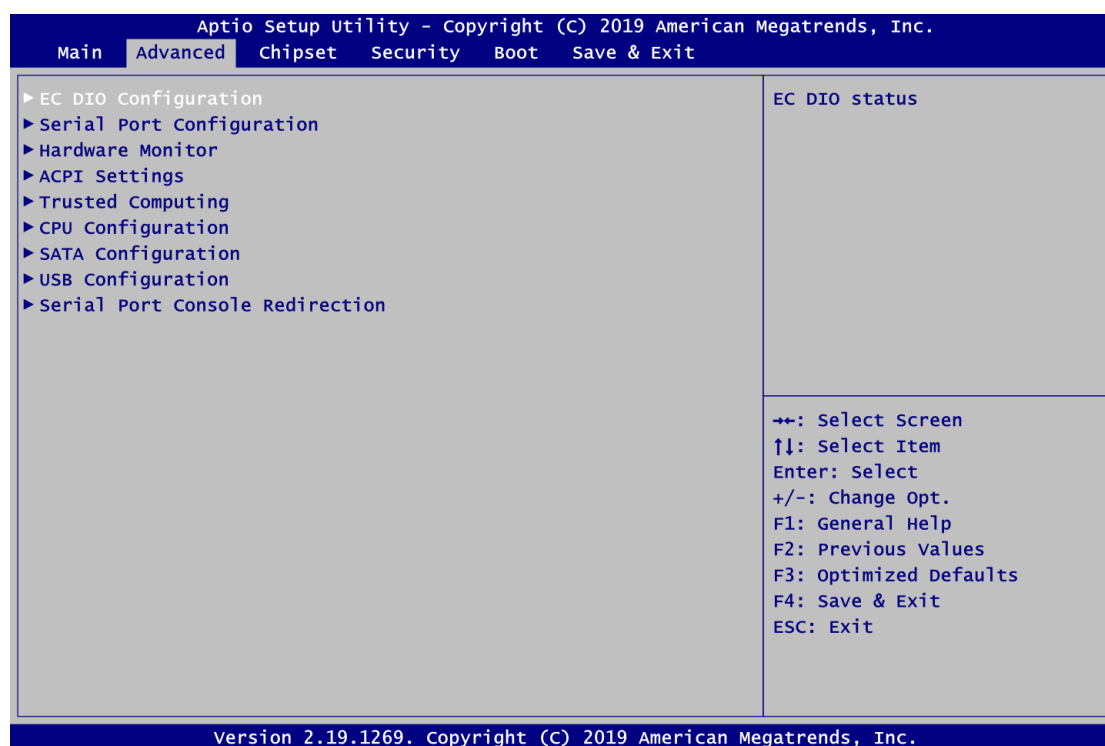

- **EC DIO Configuration**

You can use this screen to select options for Digital I/O (DIO) Configuration. A description of selected item appears on the right side of the screen. For items marked with “▶”, please press <Enter> for more options.

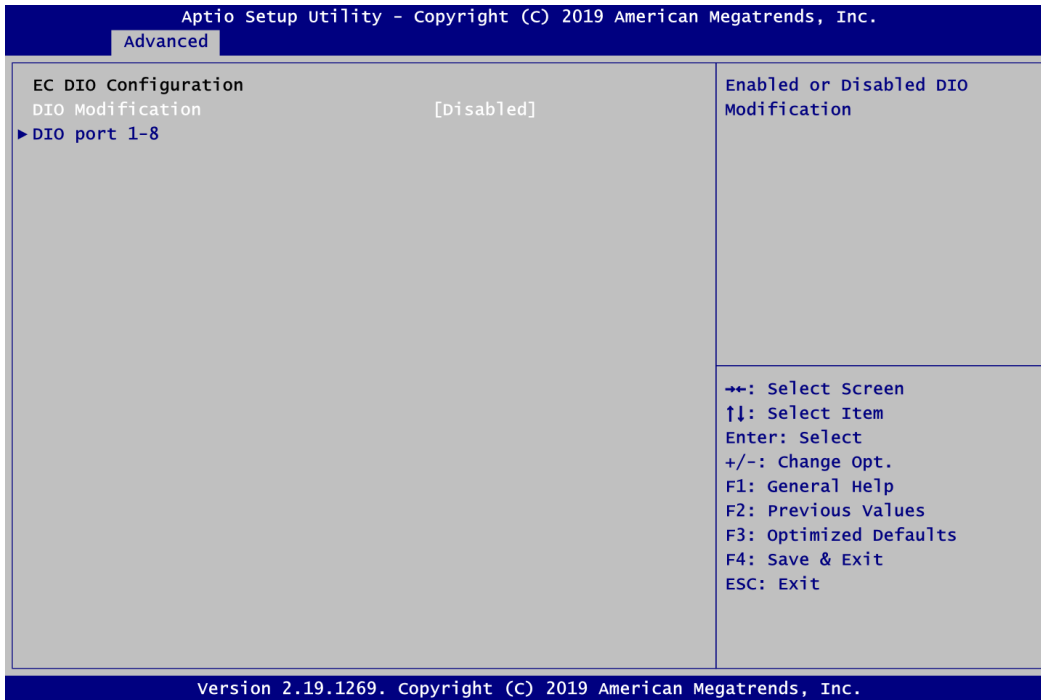

DIO Modification

Enable or disable digital I/O modification. The default is Disabled.

DIO port 1-8

Select this option to open DIO status sub screen.

If DIO Modification is disabled, you are not allowed to change inputs/outputs setting. The DIO status sub screen is as follows:

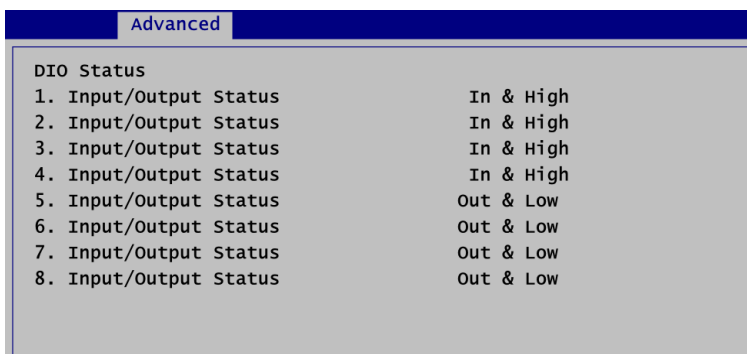

If DIO Modification is enabled, you can load manufacture default and access to the DIO status sub screen to change inputs/outputs setting, see images below.

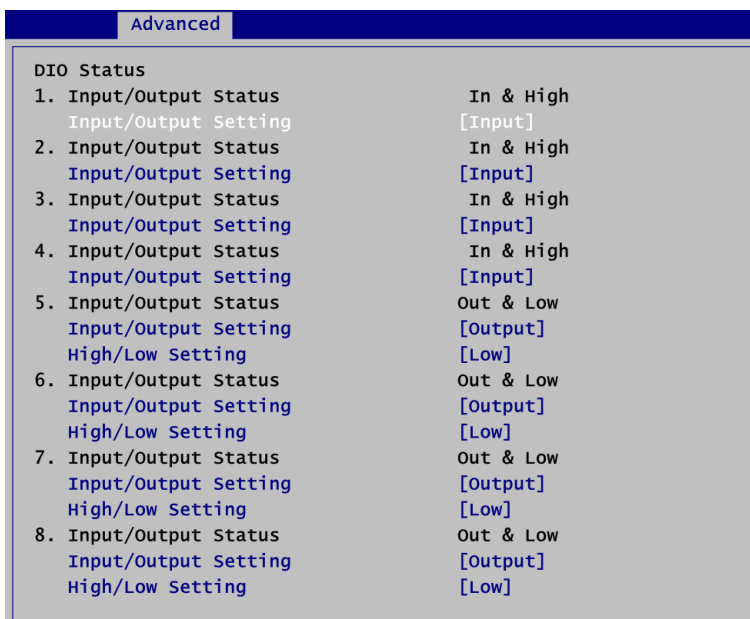
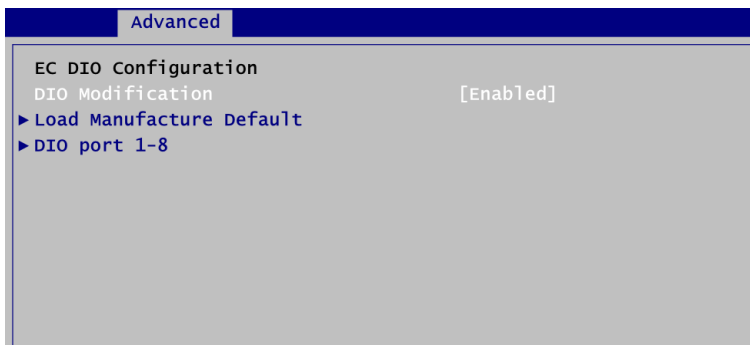

- **Serial Port Configuration**

You can use this screen to select options for the Serial Port Configuration, and change the value of the selected option. A description of the selected item appears on the right side of the screen. For items marked with "▶", please press <Enter> for more options.

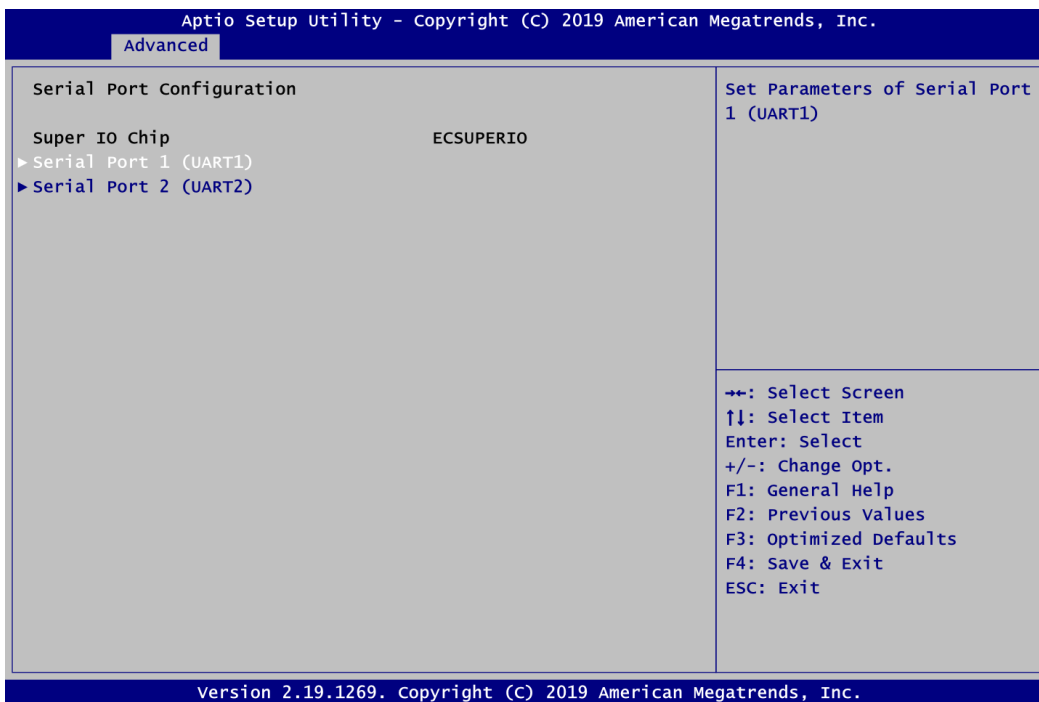

Serial Port 1~2 (UART1~2)

Set parameters related to serial port 1~2.

- **Serial Port 1 (UART1)**

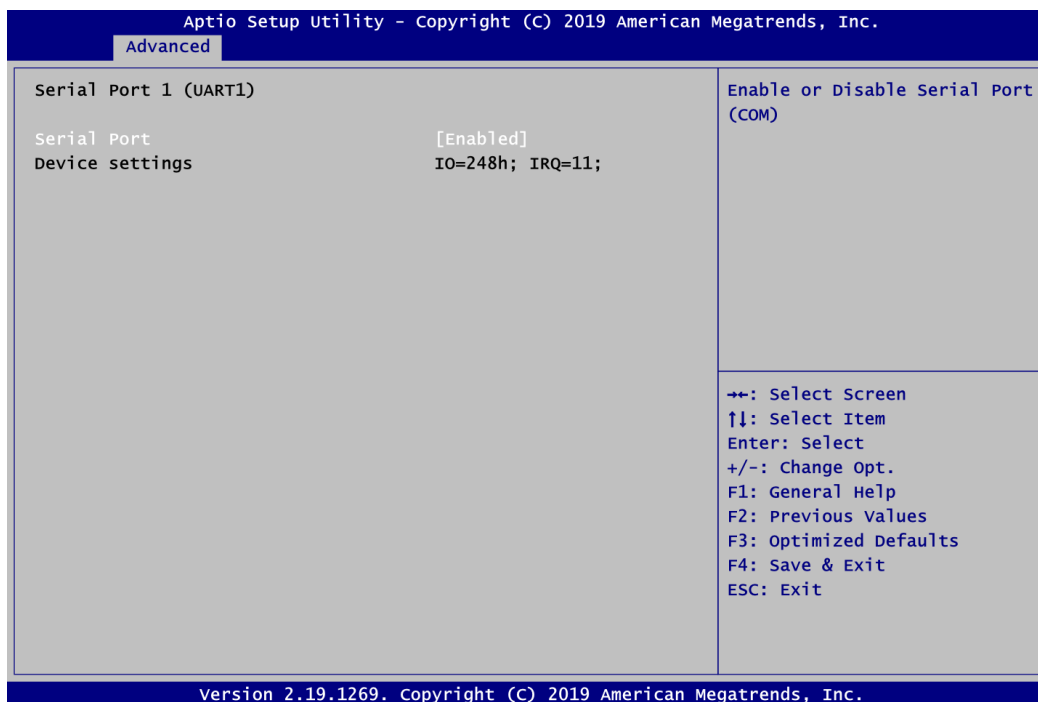

Serial Port

Enable or disable serial port 1. The optimal setting for base I/O address is 248h and for interrupt request line is IRQ11.

- **Serial Port 2 (UART2)**

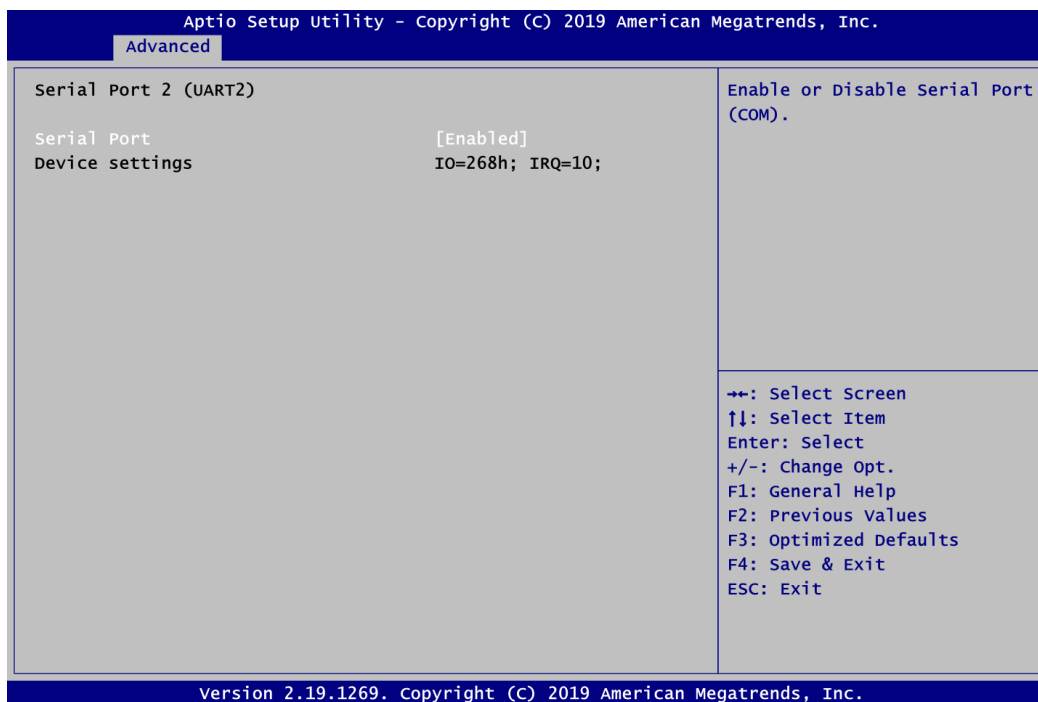

Serial Port

Enable or disable serial port 2. The optimal setting for base I/O address is 268h and for interrupt request line is IRQ10.

- **Hardware Monitor**

This screen is for fan speed control and hardware health status monitoring.

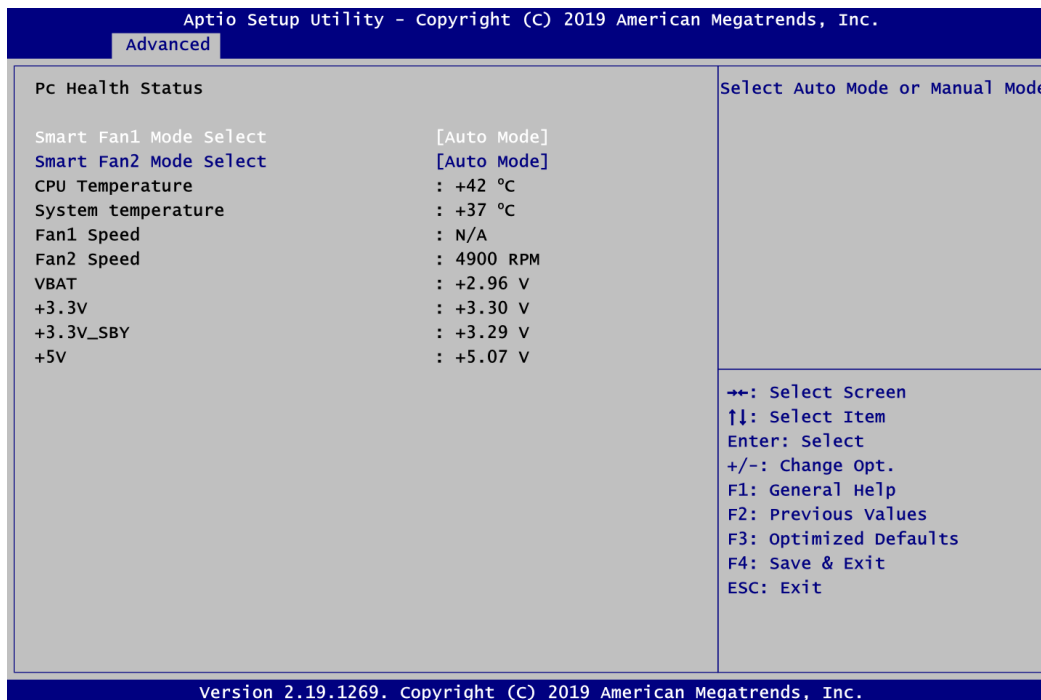

This screen displays the temperature of system and CPU, fan speed in RPM and system voltages (VBAT, +3.3V, +3.3V standby and +5V).

Smart Fan1/2 Mode Select

Set Smart Fan 1/2 mode. The default is Auto Mode. If Smart Fan is in Auto Mode, the system fan spins at different speed depending on system temperature; the higher the temperature, the faster the system fan spins. If Smart Fan is in Manual Mode, user can manually change system fan speed to 100%, 75%, 50%, 25% or 0% (see image below).

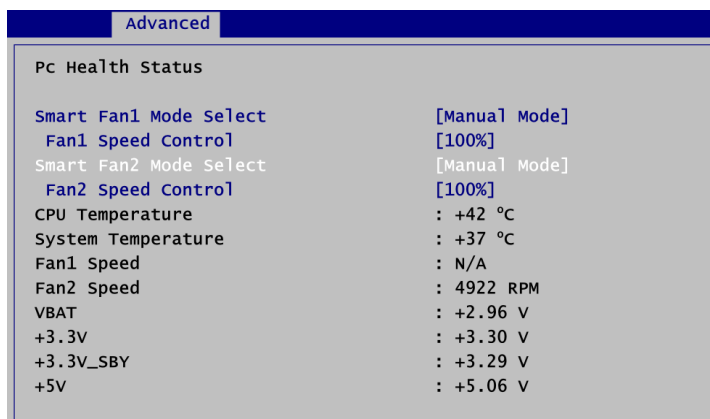

- **ACPI Settings**

You can use this screen to select options for the ACPI configuration, and change the value of the selected option. A description of the selected item appears on the right side of the screen.

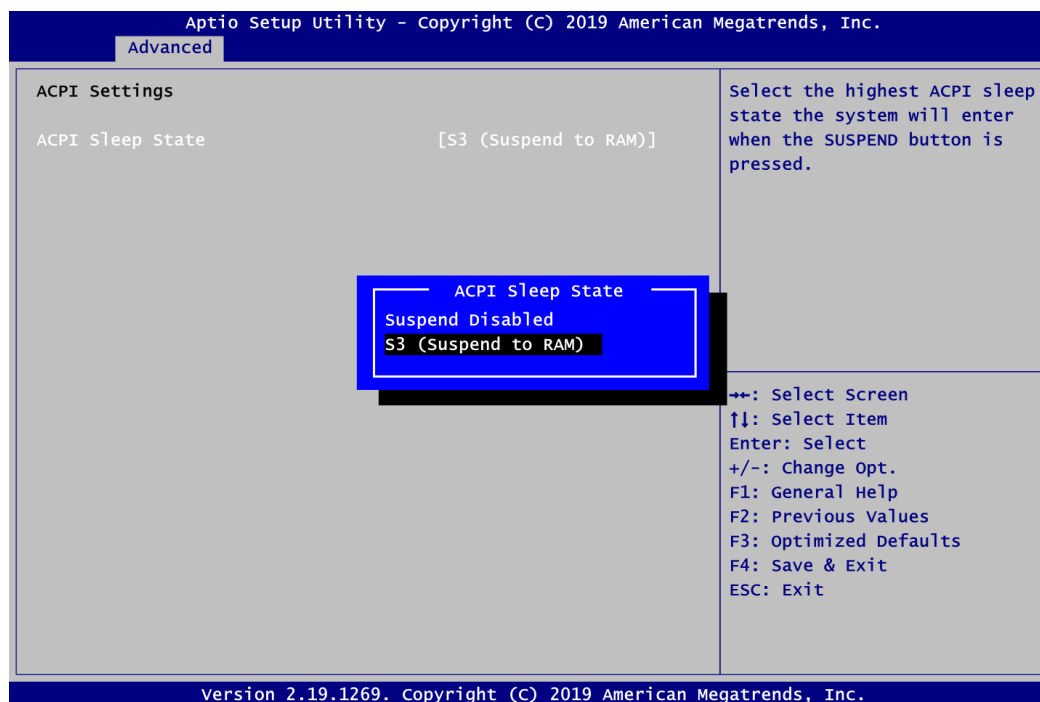

ACPI Sleep State

Select the ACPI (Advanced Configuration and Power Interface) sleep state. Configuration options are Suspend Disabled and S3 (Suspend to RAM). The S3 (Suspend to RAM) option selects ACPI sleep state the system will enter when suspend button is pressed.

- **Trusted Computing**

You can use this screen for TPM (Trusted Platform Module) configuration. It also shows current TPM status information.

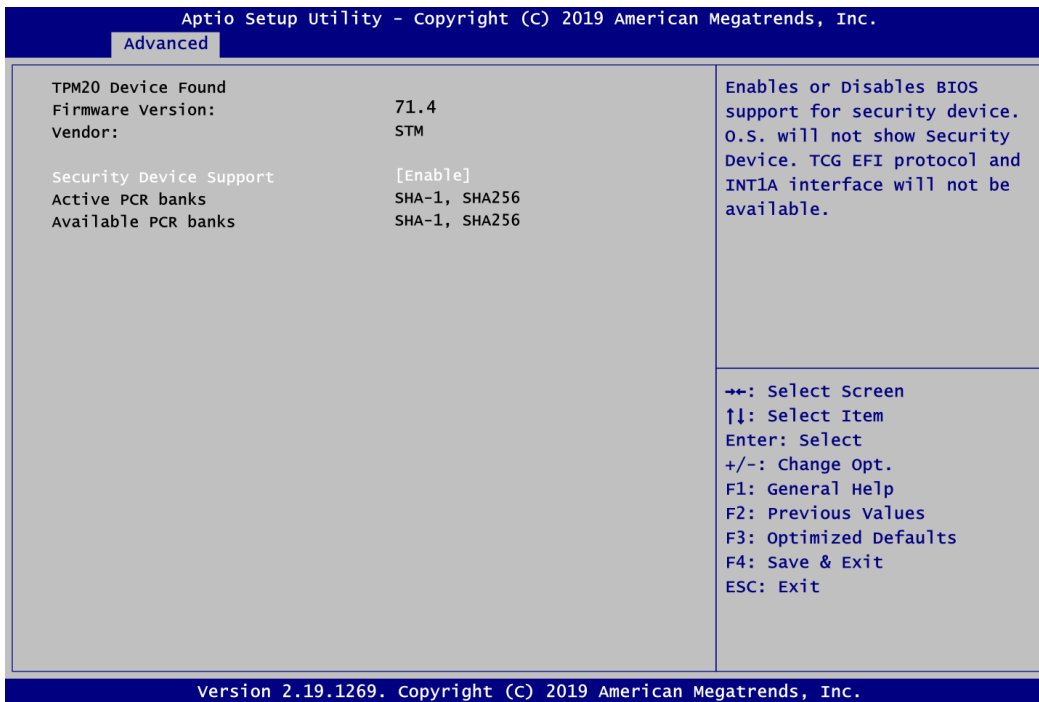

Security Device Support

Enable or disable BIOS support for security device.

- **CPU Configuration**

This screen shows CPU Configuration, and you can change the value of the selected option.

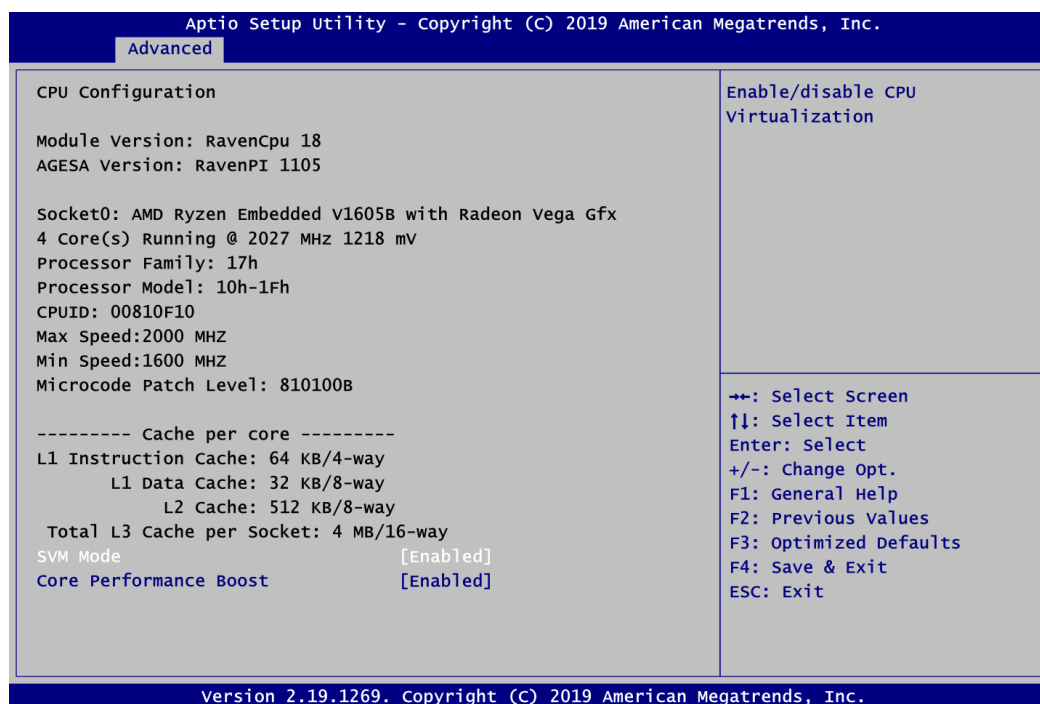

SVM Mode

Enable or disable SVM (Secure Virtual Machine) mode. Once enabled, you will be able to install a virtual machine on your system.

Core Performance Boost

If enabled, the CPU can be boosted up to its maximum clock speed when needed.

- **SATA Configuration**

In the SATA Configuration menu, you can see the currently installed hardware in the SATA ports. During system boot up, the BIOS automatically detects the presence of SATA devices.

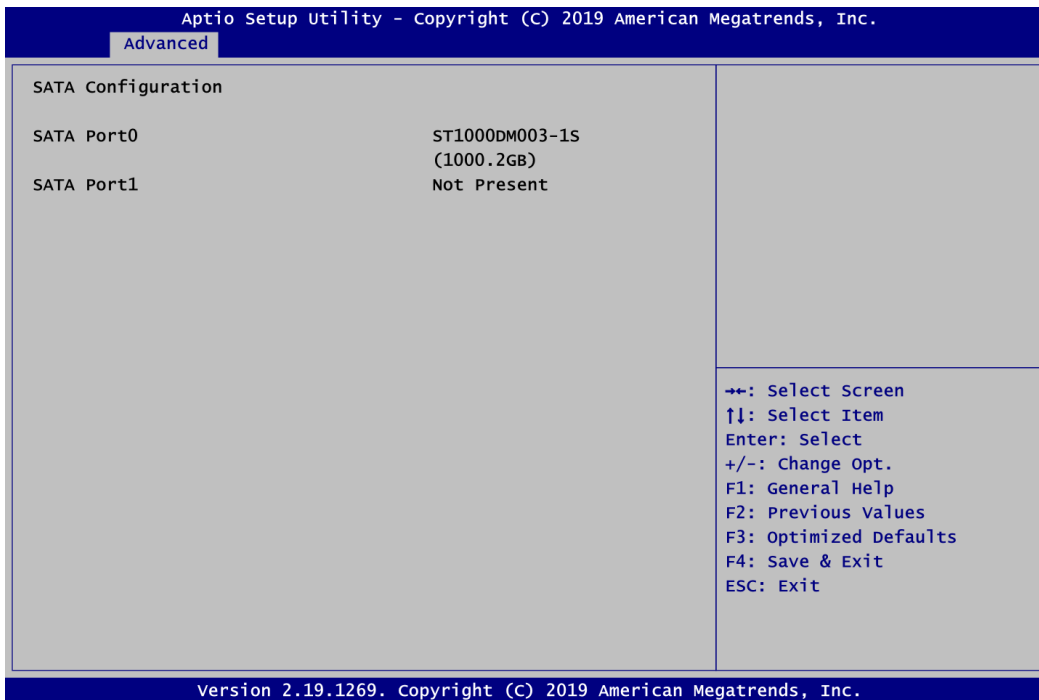

- **USB Configuration**

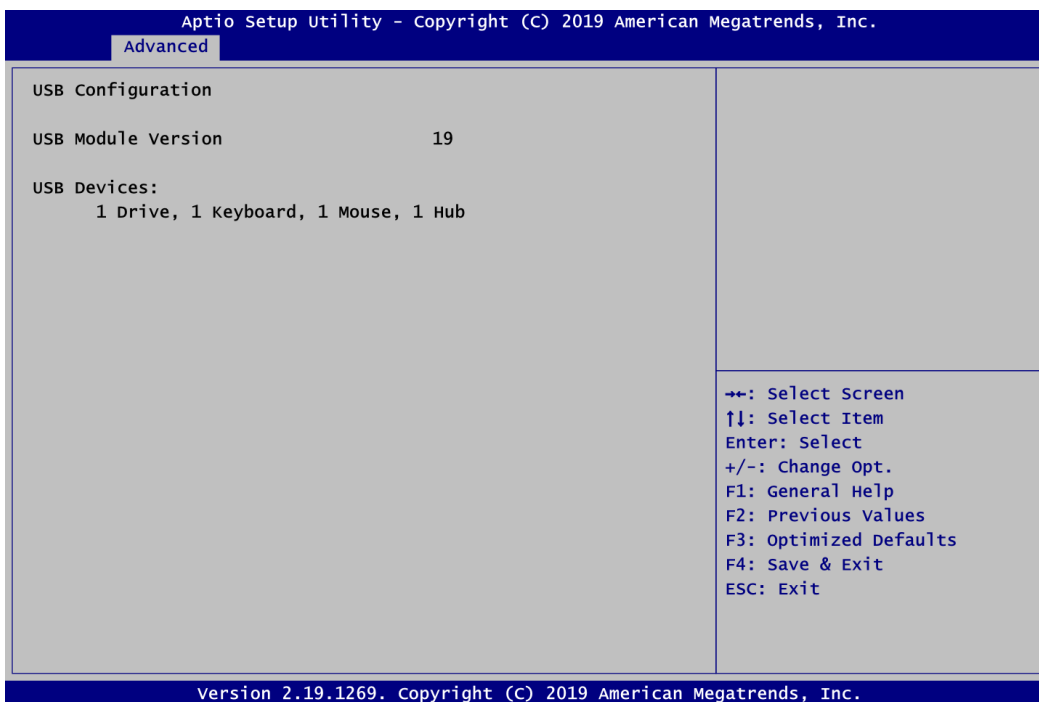

USB Devices

Display all detected USB devices.

- **Serial Port Console Redirection**

You can use this screen to select options for Serial Port Console Redirection, and change the value of the selected option. A description of the selected item appears on the right side of the screen. For items marked with “▶”, please press <Enter> for more options.

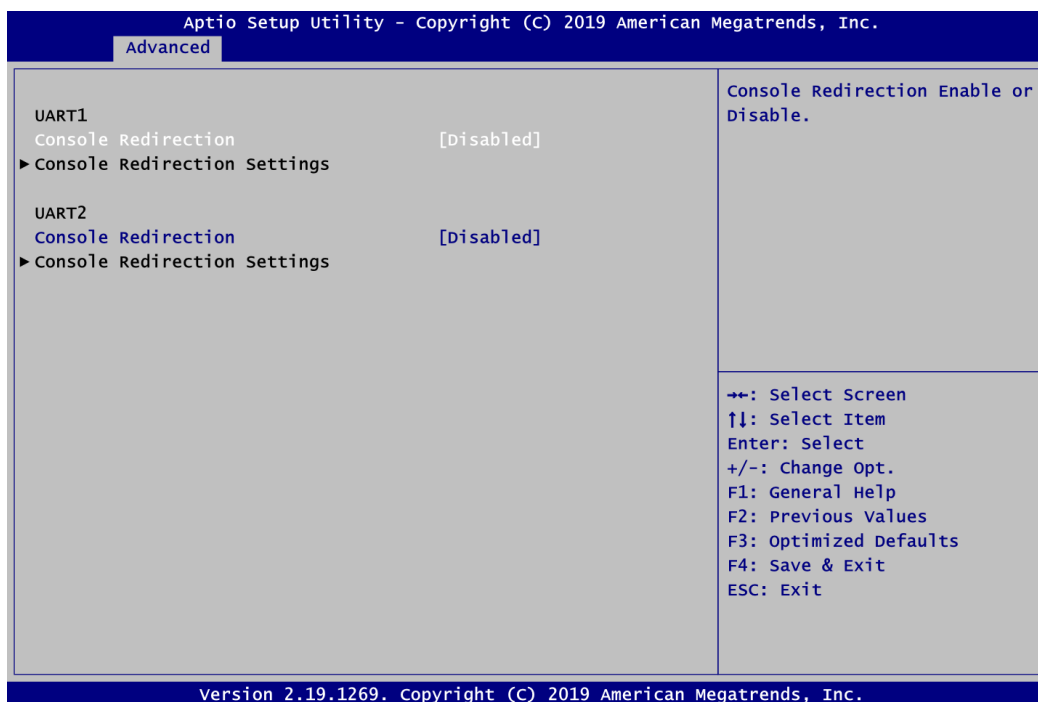

UART1\UART2 Console Redirection

Enable or disable UART1\UART2 console redirection.

UART1\UART2 Console Redirection Settings

When enabled, the settings specify how the host computer and the remote computer (which the user is using) will exchange data. Both computers should have the same or compatible settings.

- **Console Redirection Settings**

Aptio Setup Utility - Copyright (C) 2019 American Megatrends, Inc.		
Advanced		
UART1 Console Redirection Settings		Emulation: ANSI: Extended ASCII char set. VT100: ASCII char set. VT100+: Extends VT100 to support color, function keys, etc. VT-UTF8: Uses UTF8 encoding to map Unicode chars onto 1 or more bytes.
Terminal Type	[ANSI]	++: Select Screen ↑↓: Select Item Enter: Select +/-: Change Opt. F1: General Help F2: Previous Values F3: Optimized Defaults F4: Save & Exit ESC: Exit
Bits per second	[115200]	
Data Bits	[8]	
Parity	[None]	
Stop Bits	[1]	
Flow Control	[None]	
VT-UTF8 Combo Key Support	[Enabled]	
Recorder Mode	[Disabled]	
Resolution 100x31	[Disabled]	
Putty Keypad	[VT100]	
Version 2.19.1269. Copyright (C) 2019 American Megatrends, Inc.		

4.5 Chipset Menu

The Chipset menu allows users to change the advanced chipset settings. You can select any of the items in the left frame of the screen to go to the sub menus:

- ▶ North Bridge
- ▶ South Bridge

For items marked with “▶”, please press <Enter> for more options.

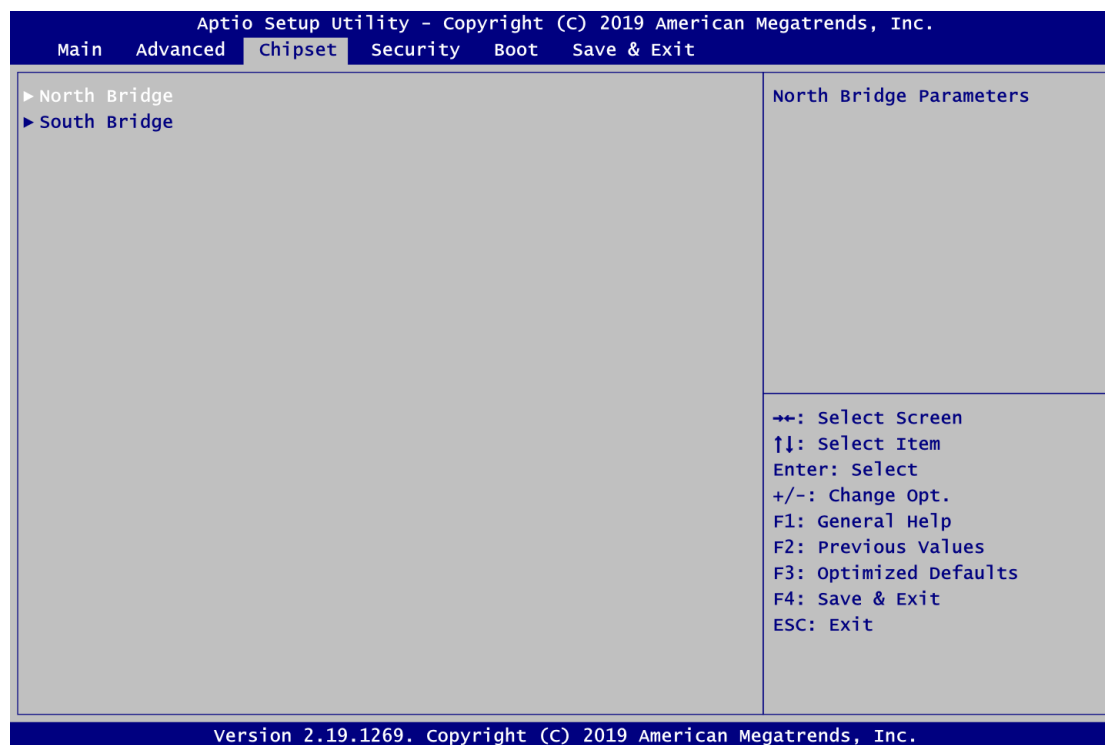

- **North Bridge**

This screen displays system memory information. And it also allows users to configure parameters of North Bridge chipset.

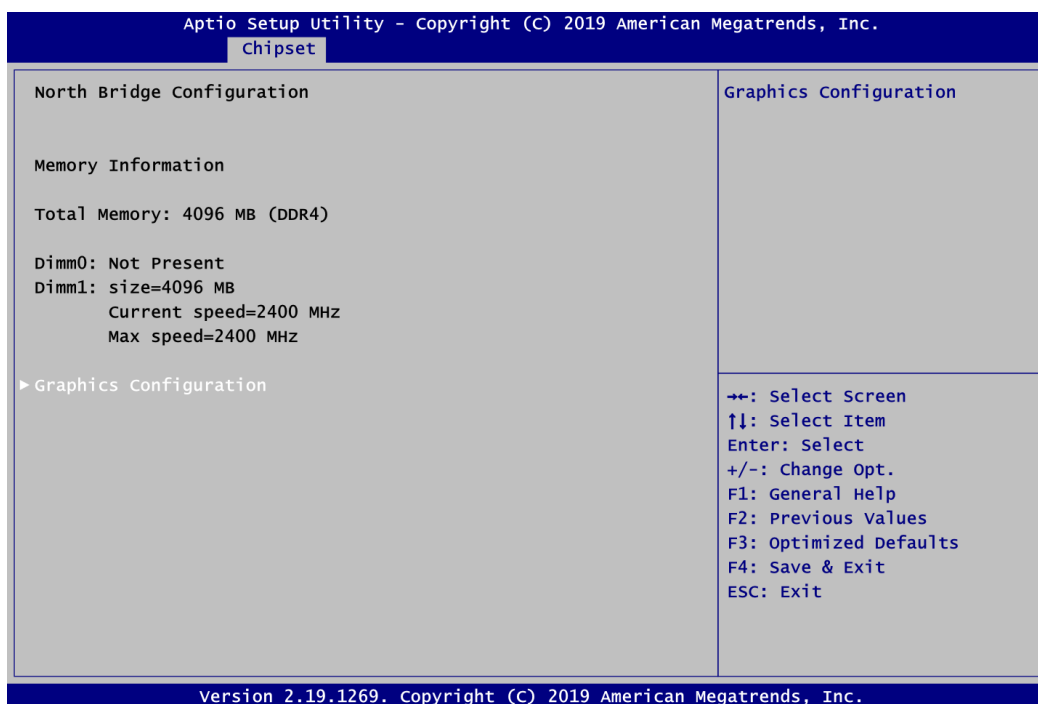

Graphics Configuration

Open sub menu for parameters related to graphics configuration.

- **Graphics Configuration**

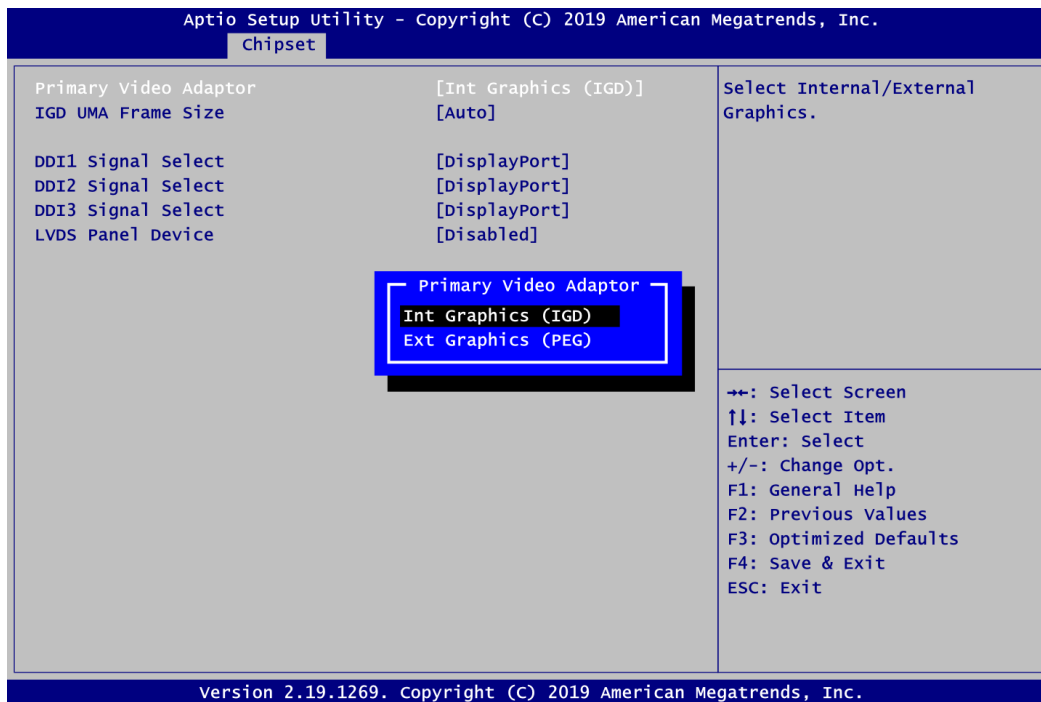

Primary Video Adaptor

Select Integrated Graphics (IGD) or External Graphics (PEG).

IGD UMA Frame Size

Set Integrated Graphics (IGD) UMA Frame Buffer Size, see image below

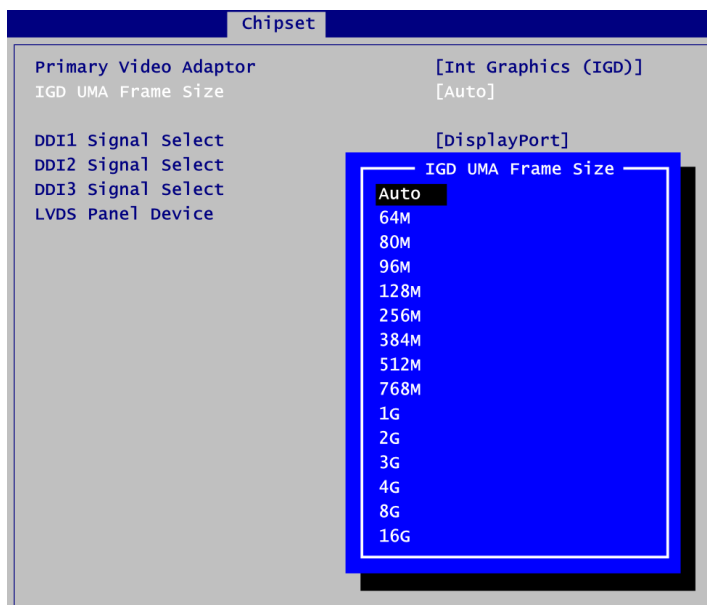

DDI1 Signal Select

Select the DDI1 signal output to DisplayPort or HDMI.

DDI2 Signal Select

Select the DDI2 signal output to DisplayPort or HDMI.

DDI3 Signal Select

Select the DDI3 signal output to DisplayPort or HDMI.

LVDS Panel Device

Enable or disable LVDS panel support. Once enabled, you will be able to go further for LVDS Panel Type setting.

LVDS Panel Type

Select the appropriate LVDS panel resolution, see image below.

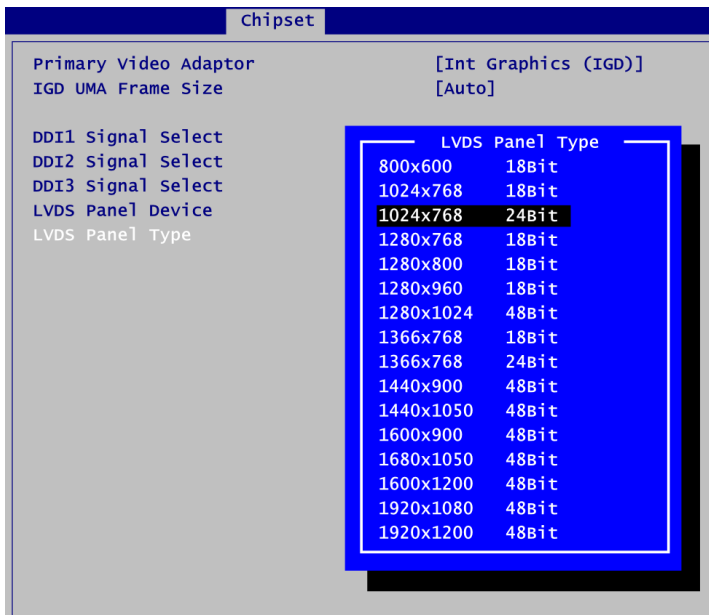

- **South Bridge**

This screen shows the AMD Reference Code Version information.

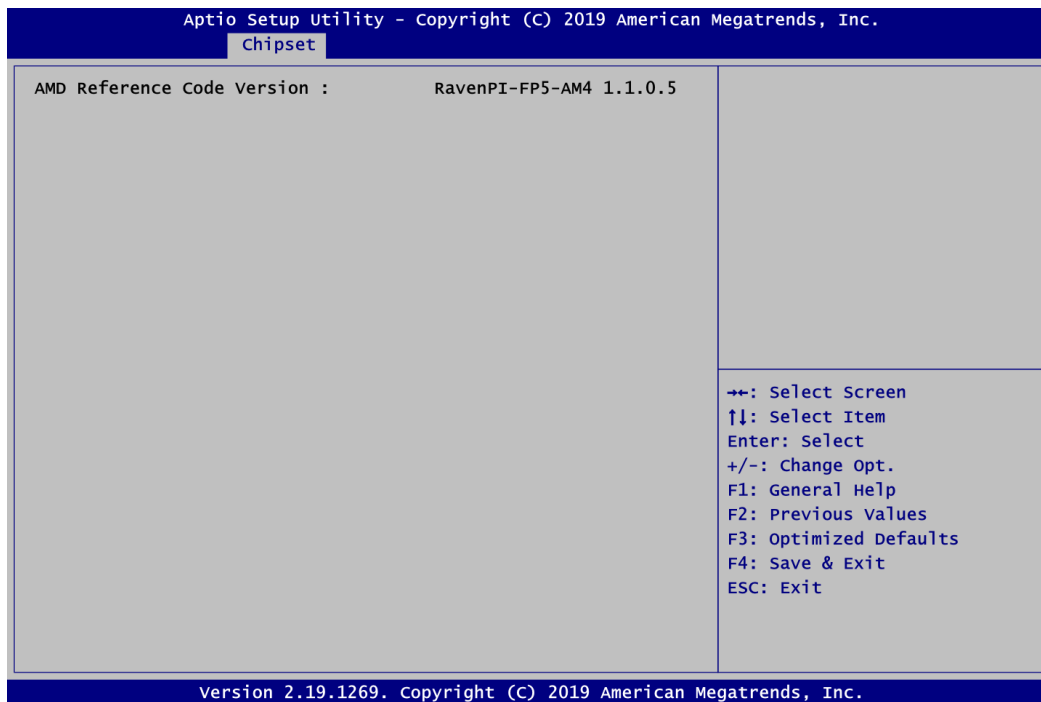

4.6 Security Menu

The Security menu allows users to change the security settings for the system.



- **Administrator Password**
Set administrator password.
- **User Password**
Set user password.

4.7 Boot Menu

The Boot menu allows users to change boot options of the system.

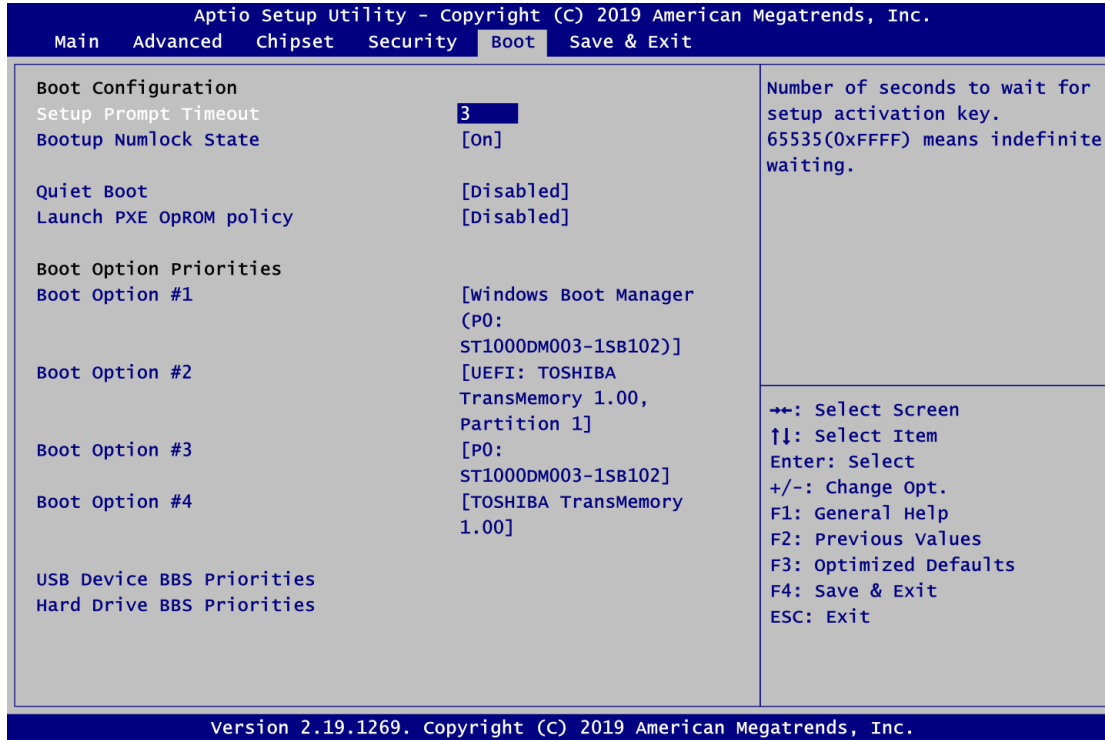

- Setup Prompt Timeout**
 Number of seconds to wait for setup activation key. 65535(0xFFFF) means indefinite waiting.
- Bootup NumLock State**
 Use this item to select the power-on state for the keyboard NumLock.
- Quiet Boot**
 Select to display either POST output messages or a splash screen during boot up.
- Launch PXE OpROM policy**
 Use this item to enable or disable the boot ROM function of the onboard LAN chip when the system boots up.
- Boot Option Priorities [Boot Option #1, ...]**
 These are settings for boot priority. Specify the boot device priority sequence from the available devices.
- USB Device/Hard Drive BBS Priorities**
 Set the boot order of the specific devices in this group. This option appears only if at least one device of this group is detected.

4.8 Save & Exit Menu

The Save & Exit menu allows users to load your system configuration with optimal or fail-safe default values.

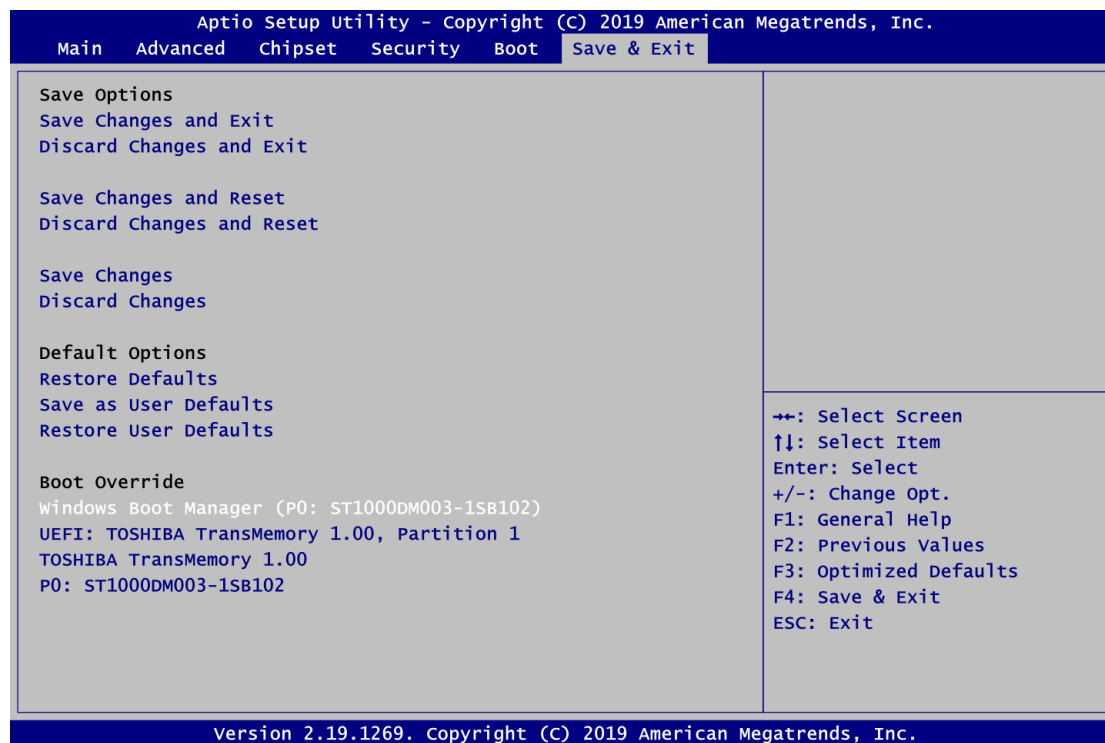

- Save Changes and Exit**
 When you have completed the system configuration changes, select this option to leave Setup and continue to boot to operating system. Select Save Changes and Exit from the Save & Exit menu and press <Enter>. Select Yes to save changes and exit.
- Discard Changes and Exit**
 Select this option to quit Setup without making any permanent changes to the system configuration and continue to boot to operating system. Select Discard Changes and Exit from the Save & Exit menu and press <Enter>. Select Yes to discard changes and exit.
- Save Changes and Reset**
 When you have completed the system configuration changes, select this option to leave Setup and reboot the computer so the new system configuration parameters can take effect. Select Save Changes and Reset from the Save & Exit menu and press <Enter>. Select Yes to save changes and reset.
- Discard Changes and Reset**
 Select this option to quit Setup without making any permanent changes to the system configuration and reboot the computer. Select Discard Changes and Reset from the Save & Exit menu and press <Enter>. Select Yes to discard changes and reset.
- Save Changes**
 When you have completed the system configuration changes, select this option to save changes. Select Save Changes from the Save & Exit menu and press <Enter>. Select Yes to save changes.

- **Discard Changes**
Select this option to quit Setup without making any permanent changes to the system configuration. Select Discard Changes from the Save & Exit menu and press <Enter>. Select Yes to discard changes.
- **Restore Defaults**
It automatically sets all Setup options to a complete set of default settings when you select this option. Select Restore Defaults from the Save & Exit menu and press <Enter>.
- **Save as User Defaults**
Select this option to save system configuration changes done so far as User Defaults. Select Save as User Defaults from the Save & Exit menu and press <Enter>.
- **Restore User Defaults**
It automatically sets all Setup options to a complete set of User Defaults when you select this option. Select Restore User Defaults from the Save & Exit menu and press <Enter>.
- **Boot Override**
Select a drive to immediately boot that device regardless of the current boot order.

Appendix A

Watchdog Timer and GPIO

A.1 About Watchdog Timer

Software stability is major issue in most application. Some embedded systems are not watched by human for 24 hours. It is usually too slow to wait for someone to reboot when computer hangs. The systems need to be able to reset automatically when things go wrong. The watchdog timer gives us solution.

The watchdog timer is a counter that triggers a system reset when it counts down to zero from a preset value. The software starts counter with an initial value and must reset it periodically. If the counter ever reaches zero which means the software has crashed, the system will reboot.

A.2 How to Use Watchdog Timer

Assembly sample code :

```
mov     dx,fa10           ; 5 seconds (Maximum is 65535 seconds; fill in
                        ; 0xFA10 and 0xFA11 register, ex: 0xFA11=0x01,
                        ; 0xFA10=0x68 means 360 seconds)
mov     al,05
out     dx,al

mov     dx,fa12           ; Enable WDT
mov     al,01
out     dx,al
```

A.3 About GPIO

The onboard GPIO (general input and output) has 8 bits (GPIO~3 and GPO0~3). In default, all pins are pulled high with +3.3V level (according to main power). The BIOS default settings are 4 inputs and 4 outputs where all of these pins are set to 1. Use these GPIO signals to control cash drawers and sense warning signals from an Uninterrupted Power System (UPS), or perform store security control.

A.4 Sample Program

Assembly sample code :

```
mov    dx,fa31      ; Set DIO 0-7 to Output
mov    al,00
out    dx,al

mov    dx,fa32      ; Set DIO 4-7 to High
mov    al,f0
out    dx,al

mov    dx,fa31      ; Set DIO 0-7 to Input
mov    al,ff
out    dx,al

mov    dx,fa32      ; Get DIO 0-7 status
in     al,dx

mov    dx,fa31      ; Set DIO 0-4 to Input, 5-7 to Output
mov    al,1f        ; al = 1F => 00011111
out    dx,al

mov    dx,fa32      ; Set DIO 6 to High
mov    al,40        ; al = 40 => 01000000
out    dx,al

in     al,dx        ; Get DIO 0-7 status
```