

# GOT5153W-834

15.6" WXGA TFT Fanless Touch Panel Computer with Intel® Celeron® Processor J1900

## Features

- 15.6" WXGA wide screen TFT LCD display with LED backlight
- 15.6" projected capacitive touch or 5-wire flat resistive touch
- Fanless design with Intel® Celeron® processor J1900
- 2.5" 7/9.5mm SATA HDD & CFast™ or mSATA
- 2 GbE LAN, 4 USB, 2 COM and speakers
- IP65 front bezel and IPX1 full enclosure
- Supports desktop stand
- Supports optional RFID or smart card reader

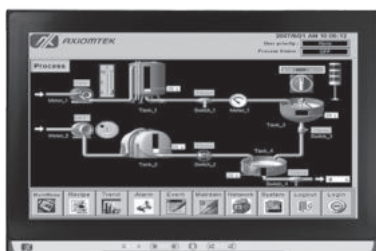

▲ CFast™ cover



▲ Rear view

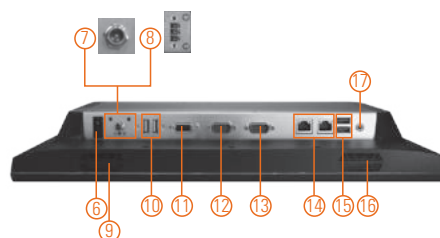

- |                                     |                                    |                            |
|-------------------------------------|------------------------------------|----------------------------|
| 1. Power LED                        | 6. Power switch (ATX)              | 12. COM 1 (RS-232/422/485) |
| 2. HDD LED                          | 7. Power input connector (Screw)   | 13. COM 2 (RS-232/422/485) |
| 3. Brightness adjust +/- (optional) | 8. Power input connector (Phoenix) | 14. Ethernet x 2           |
| 4. Display on/off (optional)        | 9. Speaker                         | 15. USB 3.0 x 2            |
| 5. Volume adjust (optional)         | 10. USB 2.0 x 2                    | 16. Speaker                |
|                                     | 11. VGA                            | 17. Audio (Line-out)       |



## Introduction

The GOT5153W-834 is a 15.6" Intel® Celeron®-based fanless touch panel computer. In response to market demand, this panel computer is a cost effective solution. It adopts a modern, sleek and fanless design and is equipped with a 15.6" TFT LCD as well as Intel® Celeron® processor J1900 4 cores (Bay Trail). For wireless network connection, the GOT5153W-834 offers 2 PCI Express Mini Card slots. By just plugging in a mini card WLAN card, customers can have instant access to wireless LAN/GPRS/GSM/4G environments. Besides, it provides two types of power input. One is DC power input (9 to 36 VDC) with terminal block connector, and another is AC power adapter with screw type connector.

### Slim & Lightweight Design

The GOT5153W-834 is slim and lightweight which make it fit for limited space installation.

### Built-in Internal WLAN Antenna

The GOT5153W-834 provides 2 PCI Express Mini Card slots and a built-in WLAN antenna for wireless network connections. By simply plugging in the wireless LAN card, customers can use the GOT5153W-834 in wireless LAN/GPRS/GPS/4G environment.

### Support Front Membrane Keys (optional)

The GOT5153W-834 provides 5 optional membrane keys in front of system, people can adjust the system display, volume and brightness.

## Specifications

Front Bezel	IP65, NEMA 4 rugged protection, plastic front bezel	
LCD Panel	Display Type	15.6" WXGA TFT LCD with LED backlight
	Brightness (cd/m <sup>2</sup> )	300 nits
	Resolution	1366 x 768
Main System	CPU	Intel® Celeron® processor J1900 4 cores
	System Memory	1 x 204-pin DDR3L-1333 MHz SO-DIMM, up to 8GB
	BIOS	AMI UEFI BIOS
	Storage	1 x 2.5" 7/9.5mm SATA HDD 1 x CFast™ or mSATA
	Watchdog Timer	255 levels, 0 to 255 sec.
	Onboard Graphics	Integrated Intel® HD GFX

## Specifications

I/O Connector	2 x RS-232/422/485 (default RS-232, COM 1/2) 1 x Switch for power on/off 2 x USB 2.0 2 x USB 3.0 1 x VGA 1 x Audio (Line-out) 2 x 10/100/1000 Mbps Ethernet (Intel® i210IT)
TPM	N/A
Expansion Interface	1 x full-size PCI Express Mini Card slot with mSATA 1 x full-size PCI Express Mini Card slot with SIM
Touchscreen	Projected capacitive multi-touch 5-wire flat resistive touch
Power Supply	1. DC version: 9 to 36 VDC with over-current protection fuse 2. AC version: 100 to 240 V AC-DC, 60W power adapter
Power Consumption	36 W
Dimensions	394.2 mm (15.53") (W) x 57 mm (2.25") (D) x 257.2 mm (10.13") (H)
Packing Dimensions	510 mm (20.09") x 190 mm (7.48") x 540 mm (21.26")
Weight (net/gross)	3.0 kg (6.61 lb) / 4.5 kg (9.92 lb)
Environment	Operating temperature: 0°C to +45°C (32°F to +113°F) w/ RAM thermal kit Relative humidity: 20% to 90% @ +40°C; non-condensing Operation vibration: 2G, 10 to 500Hz, random for CFast™
Certificate	CE

\* W.T.: Wide Temperature. All W.T. supported products have to be sorted by Axiomtek.

## Packing List

- 1 x GOT5153W-834
- 1 x Driver CD
- 1 x Adapter (GOT5153W-834-FR-J)
- 1 x Phoenix connector (GOT5153W-834-PCT-DC)

## Optional OS Installation

- Windows® 7
- Windows® 8.1
- Windows® 10

## Dimensions

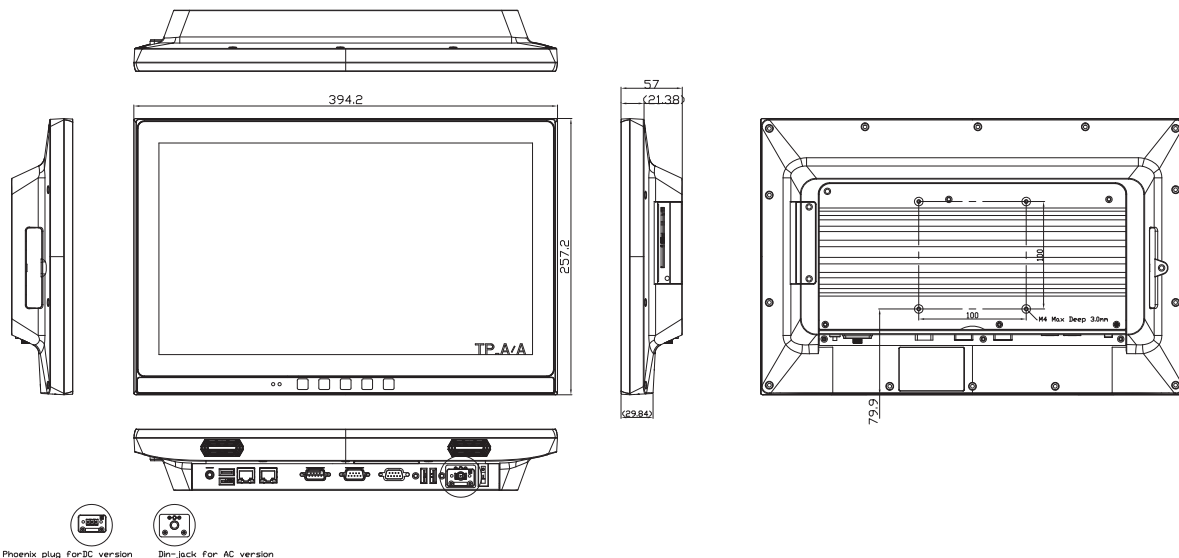

## Ordering Information

GOT5153W-834-FR-J	15.6" WXGA fanless touch panel computer with Intel® Celeron® processor J1900, 5-wire flat resistive touch screen, AC-DC 60W power adapter (screw type connector) and EMI class B
GOT5153W-834-PCT-DC	15.6" WXGA fanless touch panel computer with Intel® Celeron® processor J1900, projected capacitive multi-touch screen, and 9 to 36 VDC power input (terminal block connector)

## Optional

Wi-Fi + Bluetooth kit	
E226171106	Stand kit
881251203A0E	RFID kit
881231770A0E	Wall mount kit

## Optional EOS Installation

WES7
WE8S
Windows 10 IoT Enterprise

